

LANCIA

β MONTECARLO (SCORPION for U.S.A.)



SHOP MANUAL

ASSISTENZA TECNICA



SHOP MANUAL

β MONTECARLO (SCORPION ^{for*} U.S.A.)

Models : 137 AS - Beta Montecarlo
137 AS.6 - Beta Scorpion *

* The Beta Scorpion is the USA version of the Beta Montecarlo model.

Introduction - general recommendations Identification - specifications and data		Foreword
Engine assembly and components	01	Engine
Controls - Disc - pressure plate	02	Clutch
Gearbox or gearbox-differential (if integral) - Controls	03	Gearbox
Longitudinal and cross propeller shafts - Mechanical and hydraulic couplings	04	Transmission
Axle housing - Step-down and differential gears	05	Axle housings Not fit to this motorvehicle
Front and rear axle shafts and transverse reaction bar	06	Axle beams Not fit to this motorvehicle
Springs - shock absorbers - stabilizer bar - wishbones	07	Suspensions
Hubs - bearings - rims - tyres	08	Hubs - Wheels - Tyres
Braking components and controls	09	Brakes
Air compressors - Tanks - Valves - Pipes - Units	10	Air system Not fit to this motorvehicle
Frame or subframes for mechanical assemblies	11	Frame Not fit to this motorvehicle
Steering control units including swivels	12	Steering
Instruments - heating and ventilation - ash-trays etc.	13	Accessories
Battery - alternators - starter motor - lighting - switches etc. (excluding ignition)	14	Electric system
Body shell - bonnets - lids - windows - handles - seats - panels - mouldings etc.	15	Body
Tests requiring special equipment	16	Tests
Routine maintenance operations	17	Maintenance

HOW TO CONSULT THIS MANUAL

The manual is divided into 17 sections, each dealing with a separate assembly or group of operations (e.g. 01 Engine, 02 Clutch, 03 Gearbox, 09 Brakes etc.).

At the beginning of these sections, the list of contents may be followed by a part listing the essential features of the assembly.

This initial part of the section may also include descriptions of the workings of parts forming part of the assembly.

Each section is generally subdivided into four chapters:

CHAPTER 1 – Troubleshooting

This looks at the faults that might crop up and their likely causes, and then shows how to rectify them.

The faults indicated in this chapter are listed without numbering.

NB For the sake of completion, all faults are listed, even those which are highly unlikely to occur.

CHAPTER 2 – Repairs

This chapter describes tuning operations and adjustments and those removal-refitting jobs which can be done on the car in the workshop.

CHAPTER 3 – General overhaul of assembly

This deals with overhauls of complete assemblies which have to be done on the bench (e.g. Engine, gearbox, transmission etc. overhaul).

Of course, not all sections will have this Chapter; assembly 14, the electric system, for example cannot be overhauled at the bench.

CHAPTER 4 – Bench overhaul subassemblies

This chapter details the operations at the bench for overhauling subassemblies that may be removed directly from the car (Chapter 2) or from the full assembly, at the work bench, during general overhaul operations (Chapter 3).

(E.g. Cylinder head, oil pump etc. forming part of assembly 01 Engine).

All the operations outlined up to now form that part of each assembly known as the "Basic Model".

These operations apply to all models of the car unless specific exceptions are given in the contents of each section. In cases where operations are so different that they require special attention, the heading of the contents of each section, "BASIC MODEL" - "Operations relevant to all models" is followed by the wording "Variants - Operations relevant only for models..." followed by the variant number.

The pages in each chapter are numbered progressively and assembly section and chapter are also indicated (e.g. page 01 2/24 stands for the 24th page of Chapter 2 of Section 01 Engine).

All operations contained in Chapters 2, 3 and 4 of each section are identified by numbers of seven digits arranged in ascending order, from the first operation described in Section 01 Engine, to the last operation of Section 17 Maintenance.

The number that identifies each operation (preceded by paragraph symbol..) consists, as we have said, of seven digits:

- The first two digits (01, 02, 03, 16, 17) indicate the assembly section to which the operation belongs.
- The third digit (2, 3, 4) identifies the chapter, namely that part of the workshop in which the operation is carried out.

- The last four digits apply to the operation proper. For example, 01 2 2800 means operation 2800 of chapter 2 (third digit) of assembly section 01 (first two digits).

Use the index at the beginning of each section when looking for any operation in particular. This lists the numbers of operations with their corresponding titles, and gives the number of the page where the description can be found.

All operations described in this manual (with the same serial number) are listed in the Handbook of times which gives the standard time for performing the operation on the various models of the car.

LOOKING UP OPERATIONS

1st eventuality

- *You know the number of the operation (e.g. § 01 2 4800) and you wish to find the page where it is described.*

Number 01 2 4800 tells us that the operation should be looked up in Section 01 (first two digits) Engine in Chapter 2 (third digit).

§ 01 2 4800 R.R. coolant pump pag. 01 2/14

2nd eventuality

- You know what the operation is about (e.g. R.R. front shock absorbers) and you want to find the number of the operation and the page where it is described.

The operation will obviously be described in Section 07 Suspensions and will be found in Chapter 2 because the operation can be carried out on the car.

Reading through Chapter 2 operations in the Section 07 index, we find:

§ 07 2 0200 R.R. front suspension page 07 2/1

GENERAL RECOMMENDATIONS

Before carrying out any operation, make sure that all the equipment listed at the end of the description as well as that listed at the end of any related operation is available.

Every time a repair is done, replace all those parts which become damaged as a result of it (e.g. gaskets, oil seals, lock plates, washers, "O" rings, and so on).

References to the right or left hand sides, or the front or rear parts of the car, are with respect to the forward direction of the vehicle.

During repairs always observe the most scrupulous cleanliness at the workbench and on the parts in question.

★ ★ ★

"When new" figures shown on the technical data sheets at the end of this volume, refer to new parts that have not yet been used.

It goes without saying that it only needs a little use for these values to undergo slight variations if only as a result of running in, but such variations have nothing to do with wear proper and will in no way compromise the good performance of the parts.

★ ★ ★

During removal, repair or general overhaul operations, the fitter will have to decide for himself whether to accept pieces whose specifications, owing to wear, differ from those given on the data sheets. Of course, the general condition of the car, the assembly under repair and the type of repair being carried out should all be allowed for.

Checking and fitting roller bearings

Checking

Checks should be carried out after careful cleaning; first wash with paraffin to remove the bulkier foreign matter.

Then a more thorough wash-down should be done in tanks of clean petrol; finally the bearing is dipped in rectified petrol containing 10% lubricating oil; allow the bearing to dry without using compressed air.

Set the bearing spinning while keeping hold of the inner race; if it is not in good condition, vibrations and undue noise will be noticed and, when the bearing is spun slowly by hand, minor seizures will be felt.

The bearing should be rejected if any of the following faults are noticed:

- a) marks on races or revolving parts; marks will be easily visible on bearings that can be disassembled; on others, marks will be visible by examining races between balls, against the light;
- b) scoring of balls caused by foreign matter abrasion; in the presence of scoring; balls or rollers are greyish and lose their normal bright surface;
- c) bright outer or inner race surface; this means the bearing is spinning in its housing or on the shaft; both housing and shaft should be carefully examined because they are probably damaged;
- d) signs of seizure on outer bearing surfaces; generally speaking, rust spots on outer race surfaces do not impair the good operation of the bearing.

Fitting

Heat the bearing in an oil bath at a temperature of 80° - 100°C to facilitate fitting on the shaft.

This procedure does not apply if the bearing has a plastic cage or if the bearing is of self-lubricating type.

New bearings can be fitted without washing because their protective cover does not impair their efficient operation.

IDENTIFICATION OF CAR



Fig. 1 - Position of chassis serial number.

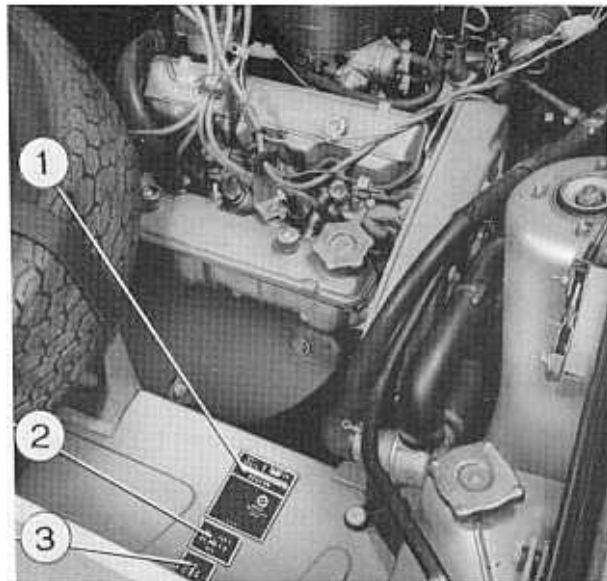

Fig. 2 - Position of car data plate.



Fig. 3 - Beta Montecarlo.

TYPES

Identification numbers		DESCRIPTION	Drive
Car	Drive		
137 AS	134 AS.000	Beta Montecarlo	LHD
137 AS/T	134 AS.000	Beta Montecarlo with sun roof	LHD

DIMENSIONS AND WEIGHTS

Overall length	3813 mm
Overall width	1696 mm
Overall height (unladen)	1190 mm
Ground clearance (laden)	190 mm
Front track (laden)	1412 mm
Rear track (laden)	1456 mm
Wheelbase (laden)	2300 mm
Kerb weight	1040 kg
Weight fully laden	1230 kg
Towable weight	800 kg

PERFORMANCE

Final drive ratio	Speeds in the various gears at 6000 rpm					
	Reverse 1 : 3.071	First 1 : 3.750	Second 1 : 2.235	Third 1 : 1.522	Fourth 1 : 1.152	1 : 0.925
14/52	45	45	80	120	155	190

Speed at 1000 rpm in 5th gear 31.66 k.p.h.

Fuel consumption according to CUNA standards (1-/100 km)

Gradients

Maximum gradient climbable in 1st gear fully laden, engine run in, on a good, straight road.	58 %
--	------

Acceleration:

Acceleration with two people aboard and changing gear as required	Sec.
standing 400 m	16.3
standing 1000 m	30.7
0-100 k.p.h.	9.8

Acceleration with minimum load and changing gear as required	Sec.
standing 400 m	16
standing 1000 m	30.2
0-100 k.p.h.	9.3

Specifications and data	
Engine	134 AS.000
Number of cylinders	4
Cylinder bore	84 mm
Total capacity	1995 cc
Compression ratio	8.9
Max power output (DIN standards)	87.3 Kw (118 hp)
Max torque (DIN standards)	16.9 (17.1 kgm) at 3400 rpm
Max revs	6000 rpm
Firing order	1-3-4-2

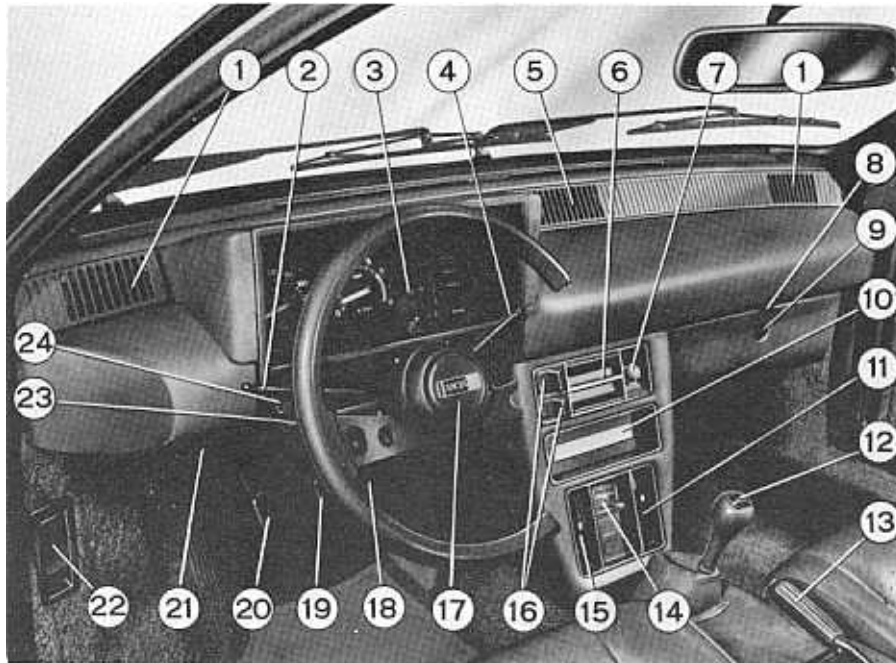

Fig. 4 - Instruments and controls

1. Side air outlets - 2. Low and high beam light switch - 3. Instrument cluster - 4. Windscreen wiper and washer control - 5. Central air outlet - 6. Ash-tray - 7. Cigarette lighter - 8. Glove compartment release lever - 9. Glove compartment lock - 10. Radio blank - 11. Heating and ventilation flow control lever - 12. Gear lever - 13. Handbrake - 14. Quartz electronic clock - 15. Heating and ventilation control levers - 16. Spare switches - 17. Horn - 18. Accelerator pedal - 19. Brake pedal - 20. Clutch pedal - 21. Fuse box - 22. Boot release control - 23. Direction indicators switch - 24. Side lights switch.

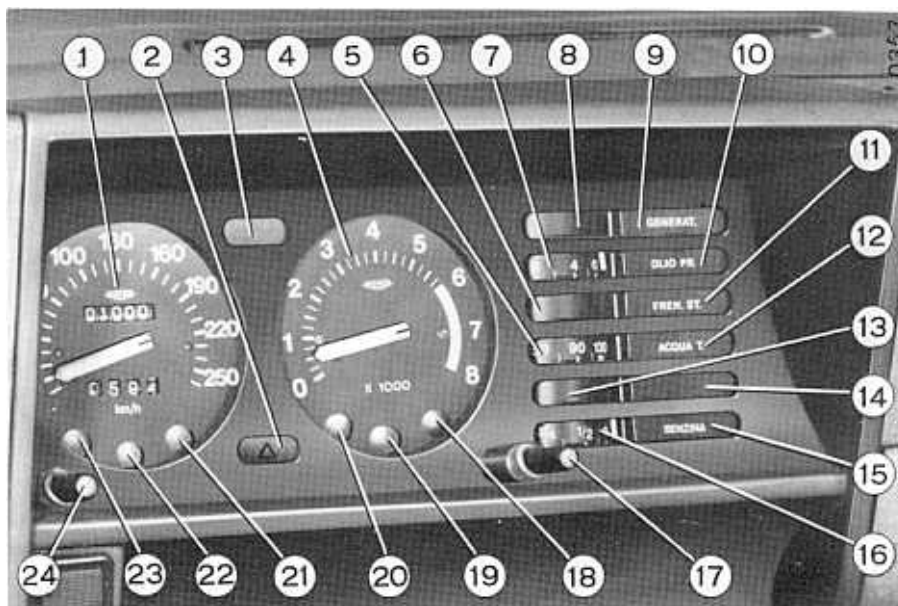
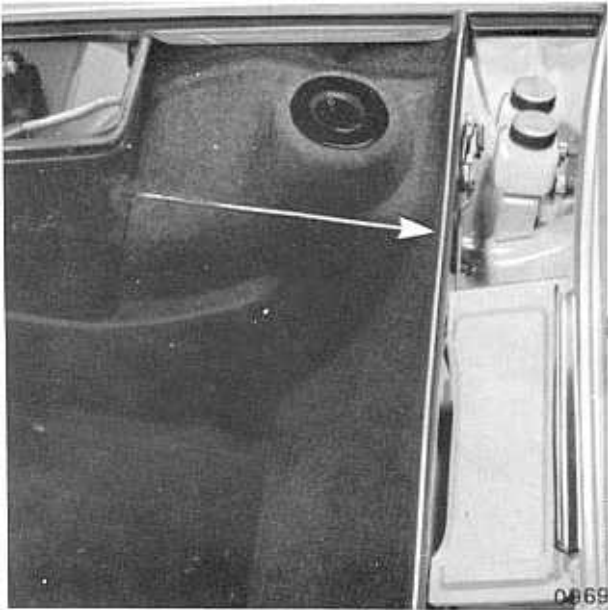
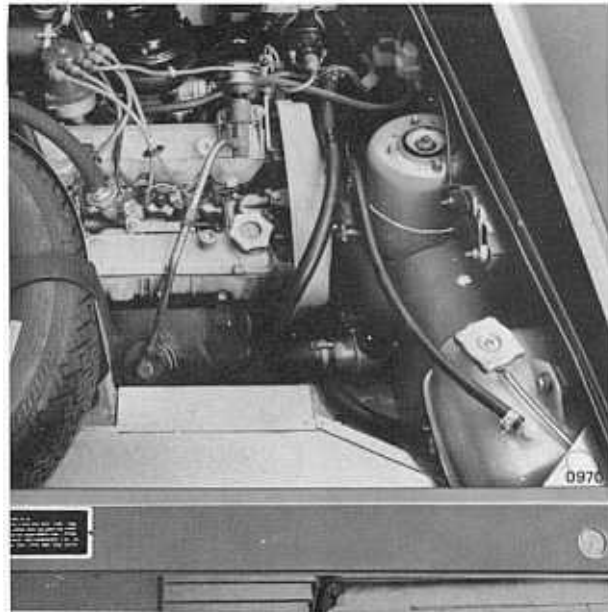

Fig. 5 - Instrument cluster

1. Speedometer with trip and total distance recorders - 2. Hazard signalling system warning light (if fitted) - 3. Direction indicator tell-tale - 4. Electronic rev counter - 5. Coolant temperature gauge - 6. Blank - 7. Oil pressure gauge - 8. Blank - 9. Alternator warning light - 10. Low engine oil pressure warning light - 11. Handbrake tell-tale (flashing) - 12. Engine overheating tell-tale - 13. Blank - 14. Blank - 15. Fuel reserve warning light - 16. Fuel gauge - 17. Instrument light with intensity adjuster - 18. Heated rear window warning light - 19. Spare tell-tale - 20. Spare tell-tale - 21. High beam tell-tale - 22. Spare tell-tale - 23. Side lights on light - 24. Trip distance recorder reset.



Position of chassis serial number.



Position of car data plate.



Beta SCORPION

T Y P E S

Identification numbers		DESCRIPTION	Drive
Car	Drive		
137 AS.6	134 AS.031.6	Beta SCORPION	LHD

DIMENSIONS AND WEIGHTS

Overall length	in.	156.10
Overall width	in.	66.77
Overall height (unladen)	in.	46.85
Front track (laden)	in.	55.59
Rear track (laden)	in.	57.32
Wheelbase (laden)	in.	99.55
Kerb weight (without optional extras)	lbs.	2.400
Payload (2 people + 130 lbs. luggage)	lbs.	430

PERFORMANCE

Final drive ratio	Speeds in the various gears at 6000 rpm					
	Reverse 1 : 3.071	First 1 : 3.750	Second 1 : 2.235	Third 1 : 1.522	Fourth 1 : 1.152	1 : 0.925
14/55	30	30	50	74	98	105

Gradients

Maximum gradient climbable in 1st gear fully lade, engine run in, on a good, straight road.	46%
---	-----

Specifications and data		
Engine		134.031.6
Number of cylinders		4
Cylinder bore	in.	3.31
Total capacity	cu in.	107.13
Compression ratio		8.0 to 1
Max power output (SAE net)	HP	81
Max torque (SAE net)	lbs. ft	89
Max revs	r.p.m.	5900
Firing order		1 - 3 - 4 - 2

1. Side air outlets - 2. Side lights control switch - 3. Turn indicator control - 4. Instrument cluster - 5. Horn control - 6. Windscreen wiper and washer control - 7. Centre air outlets - 8. Hazard signalling system switch - 9. Rear heated window switch - 10. Ash-tray - 11. Cigarette lighter - 12. Glove locker lid release lever - 13. Glove locker lock - 14. Radio blank - 15. Handbrake control lever - 16. Gear control lever - 17. Heating and ventilation flow control lever - 18. Symbols light rheostat - 19. Front seat footwells air outlet control switch - 20. Quartz electronic clock - 21. Heating and ventilation control levers - 22. Accelerator pedal - 23. Brake pedal - 24. Clutch pedal - 25. Fuse box - 26. Boot release control - 27. Main and low beams control.

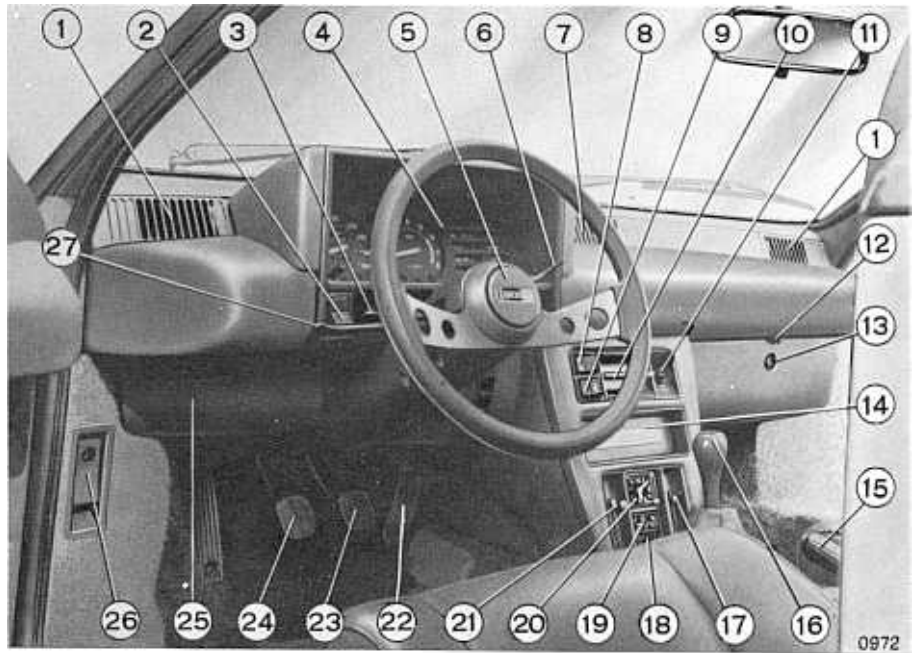

Instruments and controls

1. Trip distance recorder zero reset - 2. Speedometer with trip and total distance recorders - 3. Hazard signalling system warning light - 4. Turn indicators tell-tale - 5. Electronic rev counter - 6. Coolant temperature gauge - 7. Blank - 8. Oil pressure gauge - 9. Blank - 10. Alternator warning light - 11. Engine oil low pressure warning light - 12. Handbrake, brake system failure, or brake system low fluid level warning light - 13. Engine overheating tell-tale - 14. Blank - 15. Fasten belts warning light (driver) - 16. Fuel reserve warning light - 17. Fuel gauge - 18. Instruments light with intensity adjuster - 19. Heated rear window warning light - 20. Extra tell-tale - 21. Extra tell-tale - 22. Main beam tell-tale - 23. Extra tell-tale - 24. Side light warning light.

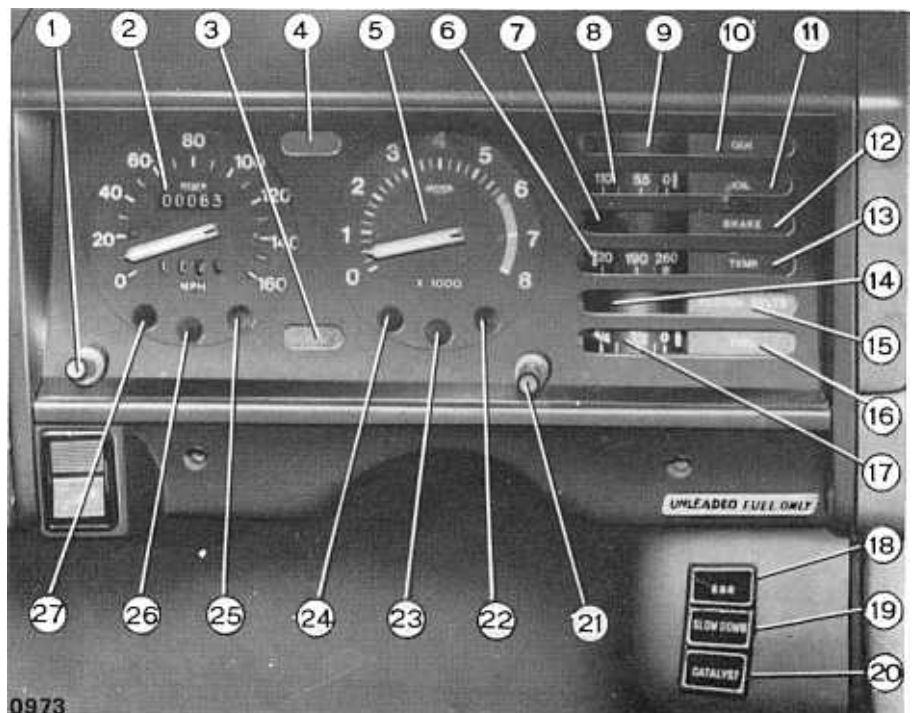

Instruments cluster

BASIC MODEL

The directions and operations refer to the engines fitted to all car models.

VARIANTS

– Variant **SCORPION**

The directions and operations refer to the engines fitted to the SCORPION versions only:

137AS 6

ENGINE GROUP CONTENTS

CHAPTER 1

Troubles, probable causes, checkings and operations to be carried out

from page 01 1/1
to page 01 1/19

CHAPTER 2

Ignition

§ 01 2 0100	Removing and refitting the spark plugs	01 2/1
§ 01 2 0200	Cleaning the ignition distributor cap contacts, rotor, cable terminals and replacing the spark plug cable terminal guards	01 2/1
§ 01 2 0300	Checking or timing the ignition	01 2/1
	Do. for Scorpion cars	01 2/1 Variant Scorpion
§ 01 2 0310	Strobe lamp ignition timing check	01 2/1 Variant Scorpion
§ 01 2 0400	Removing and refitting the ignition distributor and timing the system.	01 2/2
	Do. for Scorpion cars	01 2/2 Variant Scorpion
§ 01 2 0500	Removing and refitting the ignition coil	01 2/3

Anti-pollution equipment

§ 01 2 0690	Removing and refitting gas fluid vapor separators	01 2/3 Variant Scorpion
§ 01 2 0700	Removing and refitting gas tank ventilation valve	01 2/3 Variant Scorpion
§ 01 2 0710	Removing and refitting gas vapor cleaner . . .	01 2/4 Variant Scorpion
§ 01 2 0720	Removing and refitting of the air pump . . .	01 2/4 Variant Scorpion

§ 01 2 0730	Removing and refitting of diverter valve, three-way valve, and three way electrovalve	01 2/5 Variant Scorpion
§ 01 2 0740	Removing and refitting check valve and exhaust pipe air hose . . .	01 2/6 Variant Scorpion
§ 01 2 0780	Removing and refitting the exhaust gas recirculation valve and pipes (E.G.R.)	01 2/6 Variant Scorpion
§ 01 2 0790	Removing and refitting vacuum thermostat controlling exhaust gas recirculation valve (E.G.R.)	01 2/7 Variant Scorpion
§ 01 2 0800	Removing and refitting electrovalve for cutting out exhaust gas recirculation valve (E.G.R.)	01 2/7 Variant Scorpion
§ 01 2 0810	Removing and refitting a push-button switch on the gearbox . . .	01 2/8 Variant Scorpion
§ 01 2 0830	Removing and refitting fast idler hand control switch	01 2/8 Variant Scorpion
§ 01 2 0840	Removing and refitting fast idler control electrovalve	01 2/8 Variant Scorpion
§ 01 2 0850	Renewing the fast idling diaphragm body	01 2/9 Variant Scorpion
§ 01 2 0860	Regulating fast idler	01 2/9 Variant Scorpion
§ 01 2 0870	Removing and refitting exhaust gas recirculation (E.G.R.) system alarm	01 2/10 Variant Scorpion
§ 01 2 0880	Removing and refitting accessory gearbox	01 2/10 Variant Scorpion
§ 01 2 0890	Removal and refitting of the electronic speedometer	01 2/11 Variant Scorpion

Fuel System

§ 01 2 0900	Removing and refitting the fuel gauge transmitter with previous checking	01 2/5
§ 01 2 1100	Removing and refitting the fuel tank complete with fuel gauge transmitter	01 2/5
	Do. for Scorpion cars	01 2/3 Variant Scorpion
§ 01 2 1700	Cleaning, or renewing the air cleaner element	01 2/6
§ 01 2 1710	Removing and refitting the air cleaner assy	01 2/6
§ 01 2 1800	Removing and refitting the fuel pump (electromechanical) . . .	01 2/6
§ 01 2 1900	Removing and refitting the fuel cleaner	01 2/7
§ 01 2 2200	Cleaning the carburettor float chamber, blowing the jets and setting the slow-running	01 2/7
	Do. for Scorpion cars	01 2/3 Variant Scorpion
§ 01 2 2250	Removing and refitting the carburettor float chamber cover (Weber carburettors)	01 2/8
	Do. for Scorpion cars	01 2/14 Variant Scorpion
§ 01 2 2300	Setting the engine slow-running	01 2/8
	Do. for Scorpion cars	01 2/14 Variant Scorpion
§ 01 2 3200	Removing and refitting the carburettor including setting the engine slow-running	01 2/9
	Do. for Scorpion cars	01 2/15 Variant Scorpion
§ 01 2 3710	Removing and refitting the choke	01 2/9
§ 01 2 3800	Removing and refitting the accelerator control cable	01 2/10

Exhaust System

§ 01 2 4300	Removing and refitting the exhaust piping assembly	01 2/11
	Do. for Scorpion cars	01 2/17 Variant Scorpion

Cooling System

§ 01 2 4650	Draining refilling deaerating the cooling system	01 2/13
§ 01 2 4700	Removing and refitting the coolant radiator	01 2/13
§ 01 2 4800	Removing and refitting the coolant pump	01 2/14
§ 01 2 4900	Removing and refitting the coolant thermostatic blender	01 2/14
§ 01 2 5000	Removing and refitting the motor driven fan	01 2/15
§ 01 2 5030	Checking the motor driven fan, thermostitch and solenoid switch for operation	01 2/15
§ 01 2 5100	Removing and refitting the motor driven fan control thermostitch	01 2/16
§ 01 2 5110	Checking working condition of coolant temperature gauge, transmitter and motor driven fan cut-in and cut-out temperature	01 2/16

Lubrication System

§ 01 2 5600	Checking the oil pressure	01 2/19
§ 01 2 5700	Removing and refitting the oil pump	01 2/19
§ 01 2 6000	Removing and refitting the oil filter base to renew the gasket	01 2/19

Valve Gear

§ 01 2 6500	Checking the tappet clearance	01 2/21
§ 01 2 6600	Setting the valve tappet clearance	01 2/21
§ 01 2 6800	Checking and setting the valve gear timing (including checking the ignition timing)	01 2/23
§ 01 2 6950	Renewing the timing belt including valve gear timing and checking the ignition timing	01 2/24
§ 01 2 7010	Removing and refitting one camshaft housing (intake side), checking valve tappets clearance (removing-refitting timing belt excluded)	01 2/25
§ 01 2 7300	Removing and refitting the timing belt stretcher assy	01 2/26
§ 01 2 7500	Removing and refitting the camshaft drive gears, ancillary units shaft drive gear and timing belt drive gear	01 2/26

Cylinder Head

§ 01 2 7700	Removing and refitting the cylinder head (including checking the valve tappet clearance, but except for relative setting)	01 2/29
	Do. for Scorpion cars	01 2/19 Variant Scorpion

Engine Unit and Motive Components

§ 01 2 8100	Checking the cylinder compressions	01 2/31
§ 01 2 8200	Renewing the engine mounting buffer	01 2/31
§ 01 2 8300	Renewing the crankshaft front oil seal	01 2/32
§ 01 2 8310	Renewing the ancillary units drive shaft oil seal	01 2/34
§ 01 2 8400	Removing and refitting the engine oil sump	01 2/35
§ 01 2 8600	Removing and refitting the flywheel	01 2/36
§ 01 2 8700	Fitting a new crankshaft rear oil seal	01 2/36
§ 01 2 8800	Removing and refitting the engine (complete with gearbox)	01 2/36
	Do. for Scorpion cars	01 2/23 Variant Scorpion

CHAPTER 3

§ 01 3 0010	Engine overhaul accessory operations (removing and refitting the electric units, fitting and removing the covers and washing the engine)	01 3/1
§ 01 3 0100	Fitting the engine to the overhauling stand and removing it (including draining the engine oil and refilling)	01 3/1
§ 01 3 0250	Removing and refitting the timing belt, timing the valve gear and checking the valve tappet clearance with engine at the bench	01 3/2
§ 01 3 0300	Removing and refitting the cylinder head from the engine at the bench	01 3/3
§ 01 3 0420	Setting the valve tappet clearance with the engine at the bench	01 3/4
§ 01 3 0520	Removing and refitting the timing belt stretcher, spring, crankshaft gear, camshaft gears, ancillary units drive shaft gear and coolant pump from the engine at the bench	01 3/6
§ 01 3 0910	Removing and refitting the oil sump, oil pump, connecting rods, pistons from the engine at the bench (including relative checking)	01 3/8
§ 01 3 1100	Removing and refitting the crankshaft from the engine at the bench (including removing and refitting the ancillary units drive shaft and fuel pump and carrying out relative checkings)	01
§ 01 3 110	Substituting the ancillary units drive shaft bearings and oil pump, drive gear bushing	01 3/17
§ 01 3 2100	Cleaning the crankshaft oilways	01 3/18
§ 01 3 2300	Checking the flywheel	01 3/19
§ 01 3 2310	Renewing the flywheel ring gear	01 3/19
§ 01 3 2400	Refacing the flywheel	01 3/20
§ 01 3 2600	Replacing the engine block plugs	01 3/20
§ 01 3 2800	Reboring the cylinders	01 3/21
§ 01 3 2900	Checking the connecting rods for alignment	01 3/21
§ 01 3 3100	Replacing the connecting rod small end bushing	01 3/23

CHAPTER 4

Ignition

§ 01 4 0100	Setting the ignition distributor (Marelli 144 G)	01 4/1
§ 01 4 0300	Overhauling the ignition distributor, including final test (Marelli S144 G)	01 4/1

Fuel System

§ 01 4 1000	Overhauling and checking the Weber 34 DATR 200 carburettor	01 4/3
-------------	--	--------

Cooling System

§ 01 4 1300	General overhaul of coolant radiator	01 4/9
-------------	--------------------------------------	--------

Lubrication System

§ 01 4 2500	Overhauling the oil pump	01 4/11
-------------	--------------------------	---------

Cylinder Head

§ 01 4 2650	Removing and refitting the camshaft housings from the cylinder head on the bench	01 4/13
§ 01 4 2700	Disassembling and reassembling the cylinder head (including checking the cylinder head surface for flatness, valves, guides, valve seats and spring loading)	01 4/13
§ 01 4 2710	Refacing the valves and the seats	01 4/15
§ 01 4 3100	Renewing the valve guides (including refacing the valves and seats) .	01 4/17
§ 01 4 3300	Surfacing the cylinder head	01 4/17
§ 01 4 3400	Overhauling a camshaft housing	01 4/18

FAULT	PROBABLE CAUSES	CHECKS ADVISABLE BEFORE REPAIRING	ACTION NECESSARY	PARA.
Engine does not start (starter motor not working or running too slowly).	<p align="center">Battery</p> Terminals rusty or loose. Battery flat or partly flat.	-	Check to see that the battery is charged up and clean the terminals	14 2 0400
	<p align="center">Starter motor</p> Out of order or connections loose.	Check for loose connections.	Remove and refit starter motor. Overhaul starter motor.	14 2 6900 14 4 0420
	<p align="center">Ignition switch</p> Out of order or connections loose.	-	Remove and refit ignition switch.	-
Engine does not start (starter motor in order)	<p align="center">Ignition</p> Coil fuse blown	-	Replace fuse.	-
	Spark plugs inefficient.	-	Remove and refit spark plugs. Check spark plugs at test bench.	01 2 0100 16 4 0100

FAULT	PROBABLE CAUSES	CHECKS ADVISABLE BEFORE REPAIRING	ACTION NECESSARY	PARA.
Contd.	<p>Spark plug cables leaking or terminal contacts faulty.</p> <p>Distributor cap not insulated properly, terminals rusty or inner contacts faulty.</p> <p>Distributor rotor rusty or badly insulated.</p>	See if the fault can be corrected by fitting new, perfectly insulated cables.	Clean distributor cap contacts, rotor, and cable terminals and replace spark plug cable terminal caps.	01 2 0200
Engine does not start. (Starter motor in order).	Faulty ignition distributor (contact-breaker points rusty, gap incorrect or condenser faulty).	-	<p>Remove and refit ignition distributor and adjust ignition timing.</p> <p>Set ignition distributor and test at bench.</p> <p><i>if necessary:</i></p> <p>Partially overhaul ignition distributor and carry out bench test.</p>	<p>01 2 0400</p> <p>01 4 0100</p> <p>01 4 0300</p>
	Ignition timing faulty.	-	Check and reset ignition timing.	01 2 0400

FAULT	PROBABLE CAUSES	CHECKS ADVISABLE BEFORE REPAIRING	ACTION NECESSARY	PARA.
Contd. Engine does not start. (Starter motor in order).	Ignition coil faulty.	—	Remove and refit ignition coil. Test ignition coil at bench.	01 2 0500 16 4 0700
	<p style="text-align: center;">Fuel system</p> No fuel in tank.	—	—	—
	Fuel pump faulty.	Disconnect fuel inlet pipe from carburettor, place the end in a container, switch on starter motor and check for an outflow of fuel.	Remove and refit fuel pump.	01 2 1800
	Carburettor jets clogged.	—	Clean float chamber and blow the jets.	01 2 2200
	<p style="text-align: center;">Valve gear</p> Valve gear timing faulty.	—	Check valve gear timing and reset.	01 2 6800

FAULT	PROBABLE CAUSES	CHECKS ADVISABLE BEFORE REPAIRING	ACTION NECESSARY	PARA.
Engine lacks power	<p style="text-align: center;">Ignition</p> <p>Spark plugs faulty or wrongly heat rated</p>	Check to see whether engine misfires at high speeds.	<p>Remove and refit spark plugs.</p> <p>Test spark plugs at bench.</p>	<p>01 2 0300</p> <p>16 4 0100</p>
	<p>Ignition distributor faultily timed or not in order (wrongly gapped contact breaker points, automatic advance not working properly, rotor rusty, current leakages, etc.)</p>	—	<p>Check and time ignition.</p> <p>Remove and refit ignition distributor and time ignition.</p> <p>Set ignition distributor and test at bench</p> <p><i>if necessary:</i></p> <p>Overhaul ignition distributor and carry out final test at bench.</p>	<p>01 2 0400</p> <p>01 2 0400</p> <p>01 4 0100</p> <p>01 4 0300</p>
	<p>Ignition coil not in order.</p>	—	<p>Remove and refit ignition coil.</p> <p>Test ignition coil at bench.</p>	<p>01 2 0500</p> <p>16 4 0700</p>

FAULT	PROBABLE CAUSES	CHECKS ADVISABLE BEFORE REPAIRING	ACTION NECESSARY	PARA.
Contd.	Current leakage from spark plug cables or terminal contacts faulty.	Check to see whether the fault disappears when properly insulated cables are fitted.	Clean distributor cap contacts, rotor, cable terminals and replace spark plug terminal caps.	01 2 0200
Engine lacks power.	<p style="text-align: center;">Fuel system</p> Filter on tank suction pipe clogged.	Check to see whether the trouble is continuous, if it is not, it may be due to foreign matter in the tank.	Remove and refit fuel tank.	01 2 1100
	Fuel tank breather hose stopped.	Check breather hose visually.	Remove hose and blow with compressed air.	—
	Fuel pump in poor order.	—	Remove and refit fuel pump.	01 2 1800
	Carburettor fuel inlet filter clogged.	—	Replace filter.	—
	Air cleaner clogged.	Check to see whether exhaust fumes are black.	Clean or replace air cleaner element.	01 2 1700

FAULT	PROBABLE CAUSES	CHECKS ADVISABLE BEFORE REPAIRING	ACTION NECESSARY	PARA.
Contd.	Carburettor main jets partly clogged.	—	Clean float chamber and blow the jets.	01 2 2200
	Faulty level in carburettor float chamber.	—	Clean float chamber and blow the jets. Remove and refit float chamber cover (Weber) Check fuel level. <i>if necessary:</i> Overhaul carburettor.	01 2 2250 16 4 1150 01 4 1000
Engine lacks power.	Accelerator travel insufficient (rusty cable or sheath, pedal sticks).	Check that when accelerator is fully depressed the carburettor throttle valve is fully open.	Adjust accelerator cable <i>if necessary:</i> Remove and refit accelerator pedal.	01 2 3800
	Secondary carburettor choke does not work.	—	Remove and refit carburettor. Overhaul carburettor.	01 2 3200 01 4 1000
	Valve Gear Faulty valve clearance.	—	Check valve clearance. Reset valve clearance.	01 2 6500 01 2 6600
	Valve gear faultily timed.	—	Check and reset timing.	01 2 6800

)

✓

FAULT	PROBABLE CAUSES	CHECKS ADVISABLE BEFORE REPAIRING	ACTION NECESSARY	PARA.
<p>Contd.</p> <p>Engine lacks power.</p>	<p>Valves not tight enough.</p>	<p>—</p>	<p>Check compression. Remove and refit cylinder head. Disassemble and reassemble cylinder head.</p>	<p>01 2 8100 01 2 7700 01 4 2700</p>
	<p>Engine assembly and Drive components</p> <p>Excessive clearance between cylinders and pistons; piston rings stuck or checked.</p>	<p>Check that exhaust fumes are clear blue, especially on releasing the pedal.</p>	<p>Check compression. Remove and refit engine (for overhaul)</p>	<p>01 2 8100 01 2 8800</p>
<p>Engine not working properly, or misfires (when accelerating rapidly for example)</p>	<p>Ignition system</p> <p>Ignition coil not in good order.</p>	<p>—</p>	<p>Remove and refit ignition coil. Test ignition coil at bench.</p>	<p>01 2 0500 16 4 0700</p>
	<p>Inefficient or wrongly heat rated spark plugs.</p>	<p>—</p>	<p>Remove and refit spark plugs. Test spark plugs at bench.</p>	<p>01 2 0100 16 4 0700</p>

FAULT	PROBABLE CAUSES	CHECKS ADVISABLE BEFORE REPAIRING	ACTION NECESSARY	PARA.
Contd. Engine not working properly, or misfires (when accelerating rapidly for example)	Plug cables leaking or inefficient terminal contacts Distributor cap badly insulated, cable terminals rusty, or inner contacts faulty. Rusty or badly insulated rotor	Check to see whether trouble can be put right by fitting new, perfectly insulated cables.	Clean distributor cap contacts, rotor, cable terminals and replace spark plug cable terminal caps.	01 2 0200
	Accelerating pump delivers unevenly.	—	Remove and refit carburettor. Test carburettor at bench. <i>if necessary:</i> Overhaul carburettor.	01 2 3200 16 4 1700 01 4 1000
Engine overheating.	Ignition system Ignition distributor incorrectly timed.	—	Check and retime ignition.	01 2 0300
	Distributor automatic advance not working properly.	—	Remove and refit ignition distributor and spark plug cables after testing distributor, cable insulation and ignition timing at bench.	01 2 0400
	Fuel system Weak mixture setting.	Check to see whether inside of exhaust pipe is light coloured.	Remove and refit carburettor. Test carburettor at bench. Overhaul carburettor.	01 2 3200 16 4 1700 01 4 1000

FAULT	PROBABLE CAUSES	CHECKS ADVISABLE BEFORE REPAIRING	ACTION NECESSARY	PARA.
Contd.	<p align="center">Cooling system</p> <p>Coolant pump drive belt not tight enough.</p>	Check belt tension.	Tighten the belt.	—
	Electric fan does not work.	Disconnect input cable from electric fan and check to see whether fan works or not by connecting it directly to positive terminal of battery.	Remove and refit electric fan.	01 2 5000
Engine overheating.	Electric fan thermostwitch out of order.	—	Test operation of thermostwitch.	01 2 5030
	Electric fan solenoid switch out of order.	Disconnect input cable from electric fan and check to see whether fan works or not by connecting it directly to positive terminal of battery.	Remove electric fan solenoid switch and replace.	
	Coolant circulation thermostat out of order.	—	Remove and refit coolant circulation thermostat.	01 2 4900

FAULT	PROBABLE CAUSES	CHECKS ADVISABLE BEFORE REPAIRING	ACTION NECESSARY	PARA.
Contd.	Coolant pump out of order.	—	Remove and refit coolant pump.	01 2 4800
	Coolant radiator clogged	—	Remove and refit coolant radiator	01 2 4700
Engine overheating.	Valve gear Valve clearance faulty.	—	Check valve clearance. Adjust valve clearance.	01 2 6500 01 2 6600
	Valve timing faulty.	—	Check and retime valve gear.	01 2 6800
	Exhaust Exhaust pipes or silencer clogged.	—	Remove and refit exhaust pipe.	01 2 4300

FAULT	PROBABLE CAUSES	CHECKS ADVISABLE BEFORE REPAIRING	ACTION NECESSARY	PARA.
Contd. Engine overheating.	Cylinder head gasket blown.	—	Remove and refit cylinder head. <i>if necessary:</i> Surface cylinder head.	01 2 7700 01 4 3300
Engine slow running mechanism faulty.	<p style="text-align: center;">Ignition system</p> Spark plugs defective.	—	Remove and refit spark plugs. Test plugs at bench	01 2 0100 16 4 0100
	Spark plug cables leaking or terminal contacts faulty. Distributor cap badly insulated, cable terminals rusty, or inner contacts faulty. Rotor rusty or badly insulated.	—	Clean distributor cap contacts, rotor, cable terminals and replace spark plug cable terminal caps.	01 2 0200
	Ignition distributor faulty (rusty or breaker contact points wrongly gapped).	—	Remove and refit ignition distributor and spark plug cables after testing distributor, cable insulation and timing at bench. Reset ignition distributor and carry out final test at bench.	01 2 0400 01 4 0100

FAULT	PROBABLE CAUSES	CHECKS ADVISABLE BEFORE REPAIRING	ACTION NECESSARY	PARA.
Contd. Engine slow running mechanism faulty.	<p style="text-align: center;">Fuel System</p> <p>Air cleaner clogged.</p>	Check to see whether exhaust fumes are black on depressing accelerator.	Clean or change air cleaner element.	01 2 1700
	Carburettor slow-running jet obstructed or wrongly set.	—	Clean float chamber, blow jets and set slow-running mechanism.	01 2 2200
	Float chamber level wrong.	—	Remove and refit float chamber cover. Check fuel level. ✓	01 2 2250 16 4 1150
	Slow running mechanism wrongly set.	—	Adjust engine slow-running mechanism.	01 2 2300
	Carburettor choke wrongly adjusted.	—	Remove and refit choke after resetting it.	—
	<p style="text-align: center;">Valve gear</p> <p>Valve gear badly timed.</p>	—	Check and reset valve gear timing.	01 2 6800

FAULT	PROBABLE CAUSES	CHECKS ADVISABLE BEFORE REPAIRING	ACTION NECESSARY	PARA.
Uneven engine oil consumption.	<p align="center">Lubrication system</p> <p>Oil leak from the gasket between oil filter and alternator support and the crankcase.</p>	Check visually.	Remove and refit oil filter and alternator support and replace gasket.	01 2 6000
	<p>Oil leak from low pressure warning light switch or pressure gauge transmitter.</p>	Check visually.	Remove and refit the low pressure warning light switch. Remove and refit pressure gauge transmitter.	01 2 6050 01 2 6150
	<p>Oil leak from oil filter seal.</p>	Check visually.	Replace oil filter.	—
	<p align="center">Cylinder head</p> <p>Valve guide oil seals worn out.</p>	Check for light blue smoke from exhaust pipe especially on releasing accelerator pedal.	Remove and refit cylinder head. Replace valve guides.	01 2 7700 01 4 3100
	<p>Oil leaks from front or rear gaskets, camshaft bearing seals, or from camshaft bearing seals and housings.</p>	Check visually.	Remove and refit camshaft housing. Overhaul camshaft housings.	01 2 7010 01 4 3400
	<p>Excessive play of piston rings in cylinders, or piston rings stuck.</p>	Check for light blue smoke from exhaust pipe.	Check cylinder compression. Remove and refit engine (for overhaul)	01 2 8100 01 2 8800

FAULT	PROBABLE CAUSES	CHECKS ADVISABLE BEFORE REPAIRING	ACTION NECESSARY	PARA.
Uneven engine oil consumption.	Crankshaft or ancillary units shaft front oil seal worn out.	Check for oil leaks from crankshaft drive pinion, or ancillary units shaft drive gear.	Replace crankshaft front oil seal. Replace ancillary units shaft oil seal.	01 2 8300 01 2 8310
	Crankshaft rear oil seal worn out.	Check for oil leaks from crankcase rear side.	Replace crankshaft rear oil seal.	01 2 8700
Uneven fuel consumption.	<p style="text-align: center;">Fuel system</p> Fuel tank leaking.	Check visually.	Remove and refit fuel tank.	01 2 1100
	Fuel leaks from piping on fuel tank.	Check visually.	Correct as necessary.	-
	Carburettor choke stays partly or fully on.	-	Remove and refit choke control.	01 2 3700

FAULT	PROBABLE CAUSES	CHECKS ADVISABLE BEFORE REPAIRING	ACTION NECESSARY	PARA.
Contd. Uneven fuel consumption.	Carburettor jet sizes different from specification, needle valve stuck.	—	Remove and refit carburettor cover. Check fuel level. Replace jets.	01 2 2250 16 4 1150 01 4 1000
	Engine air cleaner clogged.	Check to see whether exhaust fumes are black.	Clean or replace air cleaner element.	01 2 1700
	Excessive acceleration pump delivery.	—	Remove and refit carburettor. Test carburettor at bench. Overhaul carburettor.	01 2 3200 16 4 1700 01 4 1000
Excessive engine noise.	<p style="text-align: center;">Ignition</p> Ignition timing faulty.	Check to see whether engine is pinking (especially when accelerating at low revs in high gear).	Check and set ignition timing.	01 2 0300
	<p style="text-align: center;">Fuel system</p> Low octane rated fuel.	As above.	Replace with prescribed octane rated fuel.	—
	<p style="text-align: center;">Exhaust system</p> Blown cylinder head-to-exhaust manifold, or exhaust manifold-to-exhaust pipe gaskets.	—	Replace gasket.	—

FAULT	PROBABLE CAUSES	CHECKS ADVISABLE BEFORE REPAIRING	ACTION NECESSARY	PARA.
Contd.	Cracked exhaust pipes or silencers.	—	Remove and refit exhaust pipes system.	01 2 4300
	<p style="text-align: center;">Cooling system</p> Noisy pump.	—	Remove and refit coolant pump.	01 2 4800
Excessive engine noise.	<p style="text-align: center;">Valve gear</p> Valve clearance faulty.	—	Adjust tappet clearance.	01 2 6600
	Valve gear drive belt stretcher bearing worn out.	—	Replace valve gear drive belt stretcher bearing,	01 2 7300
	Valve gear tappets and respective seats worn out.	—	Remove and refit one camshaft housing. Overhaul camshaft housing.	01 2 7010 01 4 3400

FAULT	PROBABLE CAUSES	CHECKS ADVISABLE BEFORE REPAIRING	ACTION NECESSARY	PARA.
Low oil pressure.	<p style="text-align: center;">Lubrication</p> Pressure gauge or transmitter faulty.	—	Check oil pressure. Remove and refit instrument cluster. Disassemble and reassemble instrument cluster. Remove and refit oil pressure gauge transmitter.	01 2 5600 13 2 3500 13 4 0700 01 2 6150
	Pressure regulating valve or oil pump faulty.	—	Check oil pressure. Remove and refit oil pump. Overhaul oil pump.	01 2 5600 01 2 5700 01 4 2500
Oil in coolant	Cylinder head gasket badly sealed.	—	Remove and refit cylinder head.	01 2 7700
Engine tends to stall.	<p style="text-align: center;">Ignition system</p> Ignition coil partly defective.	Check to see whether fault occurs with warm engine.	Remove and refit ignition coil. Test ignition coil at bench.	01 2 0500 16 4 0700

FAULT	PROBABLE CAUSES	CHECKS ADVISABLE BEFORE REPAIRING	ACTION NECESSARY	PARA.
Contd.	<p align="center">Fuel system</p> Fuel tank breather tube clogged.	-	Disconnect tube and blow it.	-
Engine tends to stall.	Fuel level in carburettor float chamber wrong.	Check carburettor for flooding.	Remove and refit float chamber cover. Check fuel level.	01 2 2250 16 4 1150
	Carburettor not clamped tightly enough.	-	Tighten carburettor mounting nuts.	-

CHAPTER 2

IGNITION

§ 01 2 0100

REMOVING AND REFITTING SPARK PLUGS

Fit covers 88083051 and *proceed as follows*:

Removing

- Remove spare wheel and relative heat shield (SCORPION only)
- Disconnect the cables from the spark plugs.
- Remove spark plugs using spanner 88011024, extension 88091204 and tommy bar 88091207. (To test spark plugs at the bench, see 16 4 0100)

Refitting

Refit the spark plugs and reconnect the cables.

Start the engine and check for any current leak from the cable terminals.

§ 01 2 0200

CLEANING THE IGNITION DISTRIBUTOR CAP CONTACTS, ROTOR, CABLE TERMINALS AND REPLACING THE SPARK PLUG TERMINAL GUARDS.

Fit the covers 88083051 and *proceed as follows*:

Disconnect the cables from the spark plugs and from the distributor cap.

Remove the bolts and takeoff the cap from the ignition distributor.

Using very fine emery cloth, clean the rotor contact and the outside and inside contacts of the distributor cap; also check that the cap is not cracked or damp: in the former event, replace the cap, in the latter dry it by air pressure.

- Clean the spark plug cable terminals at both ends; if one or more cables is cracked, replace them.

§ 01 2 0300 *Variant*

CHECKING OR TIMING THE IGNITION

Drive the car over the pit, fit the covers 88083051, and *proceed as follows*:

Removing

- Slacken the right rear wheel clamping bolts.
- Using a hydraulic jack fitted with bracket 88097827, lift the car at the rear and rest it on stand 88097120 as in figure 01 2/1; remove the right rear wheel.



Fig. 01 2/1 - Positioning the stand.

- Working inside the engine compartment, connect one cable of the timing lamp 88015150 to the ignition coil low voltage outlet (connected to the distributor) and earth the other cable to the engine.
- Turn the ignition key to energize the ignition coil.
- Turn the crankshaft in working direction until mark (1) on the pulley is aligned with mark (2) on the timing gear cover.
- The instant the timing marks come into line, the ignition distributor breaker points should open and the timing lamp come on. If this does not occur, i.e. if the lamp comes on before the two marks are in line or, with

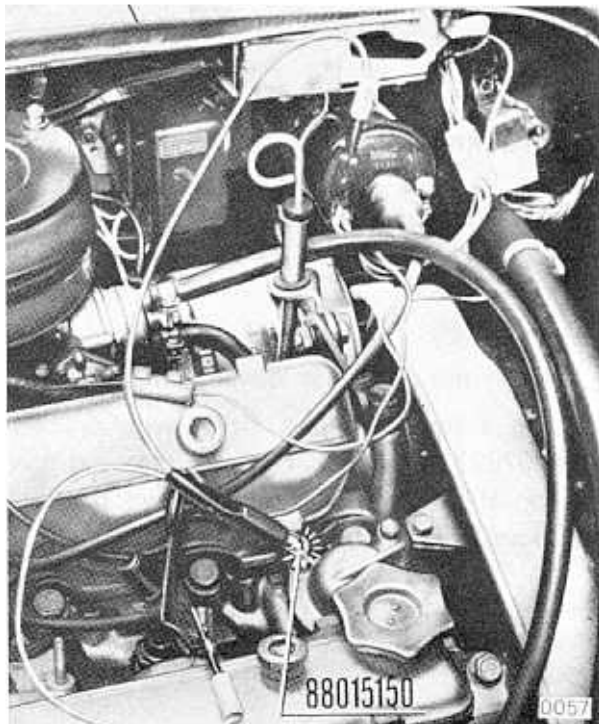

Fig. 01 2/2 Positioning lamp 88015150.

the marks in line, the lamp does not come on, set the ignition distributor as follows:

Slacken the ignition distributor retainer nut, make sure the timing marks are in line, then slowly turn the distributor in either direction to advance or retard the ignition as required.

Tighten the distributor retainer nut.

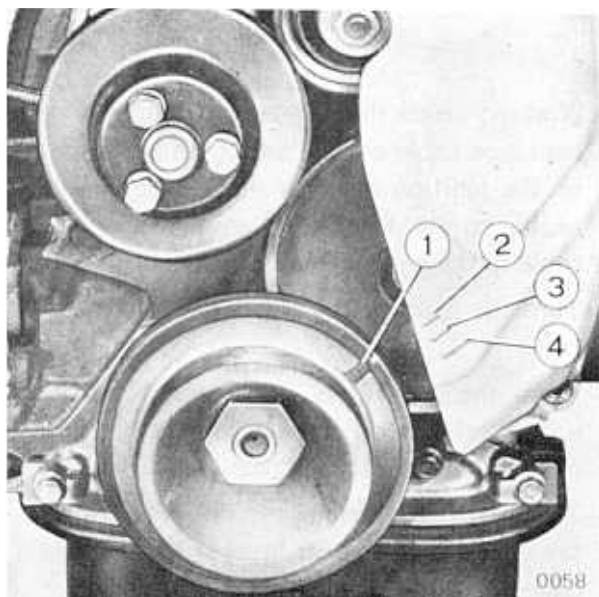

Fig. 01 2/3 Partial view of engine, timing side. Timing marks.

- Turn the crankshaft a full revolution, line up the timing marks again, and check that timing is correct.
- Disconnect the timing lamp, remove the ignition key, put the wheel back on and remove the stand.

SPECIAL TOOLS REQUIRED

- 88097120 – Stand
- 88015150 – 12 Volt timing lamp.
- 88097827 – Car raising bracket.

§ 01 2 0400 Var

REMOVING AND REFITTING THE IGNITION DISTRIBUTOR AND TIMING THE IGNITION

Drive the car over the pit, fit the covers 88083051 and proceed as follows:

Removing

- Slacken the right rear wheel clamping bolts.
- Working from below the car and using a hydraulic jack fitted with bracket 88097827, rest the car on stand 88097120 as shown in fig. 01 2/ and remove the right rear wheel.



Fig. 01 2/4 Positioning of stand.

- Turn the crankshaft until mark (1) on the pulley is in line with mark (2) on the timing gear cover; the holes (1) in the camshaft drive gears should be more or less in line with the marks (2) on the camshaft front bearings. With the marks aligned in this way cylinder Number 4 will be in the expansion stroke.

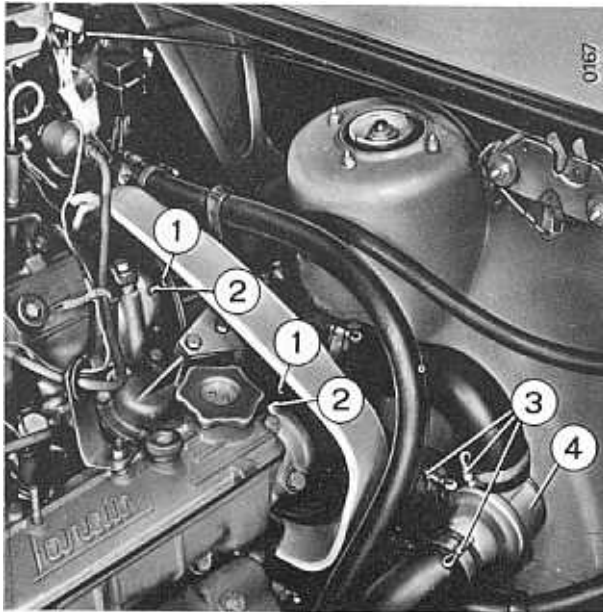

Fig. 01 2/5 - Upper part of engine position timing drive wheels during ignition phase.

- Disconnect the electric cables from the spark plugs and the high voltage cable from the distributor cap.
- Remove the bolts and lift off the ignition distributor cap complete with the cables.
- Disconnect the ignition distributor low voltage input cable.
- Remove the distributor retainer nut and extract the distributor from its seating (before removing it, make sure the rotor is positioned to ignite cylinder No. 4 (1)).

Refitting

- Position the distributor rotor to ignite cylinder No. 4.
- Fit the distributor into its seating and, holding the rotor in the specified position, insert the drive spindle in the drive gear.
- Fit the distributor retainer but do not tighten the mounting nut.

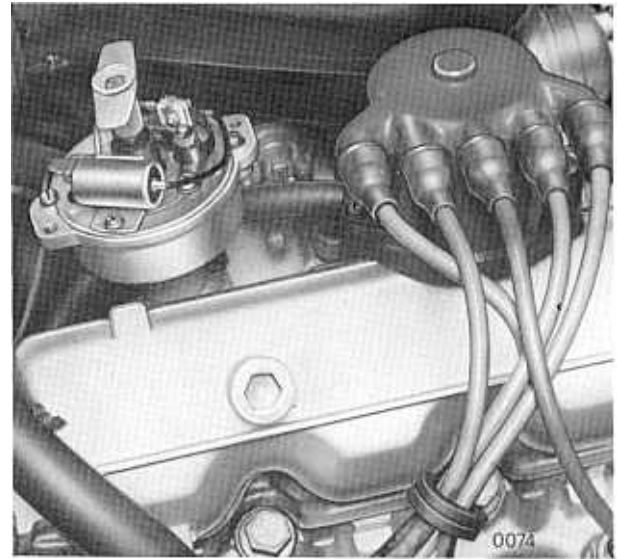

Fig. 01 2/6 - Positioning of rotor and ignition distributor.

- Time the ignition distributor, complying with the instructions given in § 01 2 0300.
- Refit the remaining parts.

SPECIAL TOOLS REQUIRED

- 88097120 – Stand
- 88097827 – Car raising bracket.

§ 01 2 0500

REMOVING AND REFITTING THE IGNITION COIL

Fit the covers 88083051 and *then proceed as follows:*

Removing

- Undo the nuts and disconnect the low voltage cables from the ignition coil.
- Disconnect the high voltage cable.
- Remove the nuts and lift off the ignition coil (2).

Refitting

- Refit in reverse order to the removing operation.

(1) For testing the ignition distributor at the bench and insulating the cables see § 16 4 0400.

(2) For testing the ignition coil at the bench see § 16 4 0700

FUEL SYSTEM

§ 01 2 0900

REMOVING AND REFITTING THE FUEL GAUGE TRANSMITTER WITH PREVIOUS CHECKING

Fit covers 88083051 and *proceed as follows*.

Removing

- Working inside the engine compartment, remove the spare wheel (also remove the heat shield (SCORPION only)).
- Drain the fuel tank, making use of the fuel pump or an appropriate outside pump.

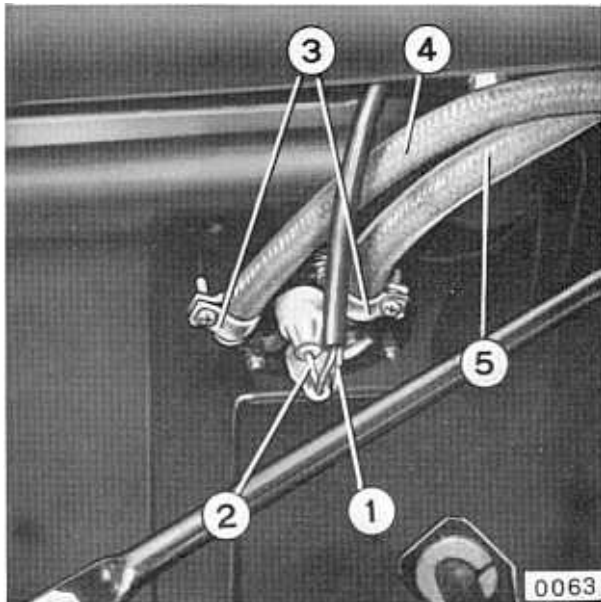

Fig. 01 2/7 - Fuel gauge transmitter

Disconnect cables (1-2) from the gauge transmitter and, with the ignition key on and the transmitter cables alternatively earthed, check that the fuel gauge pointer on the instrument panel moves from the empty position and the reserve warning light on, to maximum level position and reserve light off (1).

(1) If this does not occur, the fault will be due either to an incorrect connection or a defective fuel gauge on the instrument panel. To remove the fuel gauge, see 13 2 3500.

- Disconnect fuel delivery (3) and fuel leak-off hoses (4-5), unscrew clamping nuts (6) and remove the fuel gauge transmitter.

Refitting

- Refit the fuel gauge transmitter after replacing the gasket, proceeding in the reverse order.

§ 01 2 1100 Variant

REMOVING AND REFITTING THE FUEL TANK COMPLETE WITH FUEL GAUGE TRANSMITTER

Drive the car over the pit, fit the covers 88083051, and *proceed as follows*:

Removing

- Operating inside the engine compartment, remove the spare wheel.
- Drain the fuel tank by means of the fuel pump or a suitable substitute.

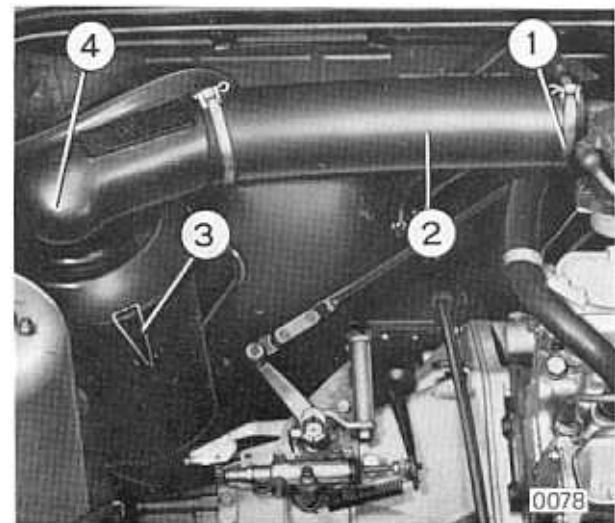

Fig. 01 2/8 - Complete air cleaner

- Slacken the clamp (1), remove the hose (2), unhook the clips (3) and remove the cover (4) complete with cleaner element; slacken the clamps holding the breather tube and the rubber sleeve of the filler, and then remove sleeve and tube.

- With reference to fig. 01 2/7 slacken the fuel delivery (3) and fuel leak-off hoses (4-5) and remove cables (1 and 2) from the transmitter.
- Remove the upper tank clamping bolts.
- Operating from below the car: remove the floor pan, remove the lower tank clamping bolts and remove the tank from below the car.
- Remove the fuel gauge transmitter from the fuel tank.

Refitting

- Refit in the reverse order to removal.

§ 01 2 1700

CLEANING OR REPLACING THE AIR CLEANER ELEMENT

Fit the covers 88083051 and then *proceed as follows*:

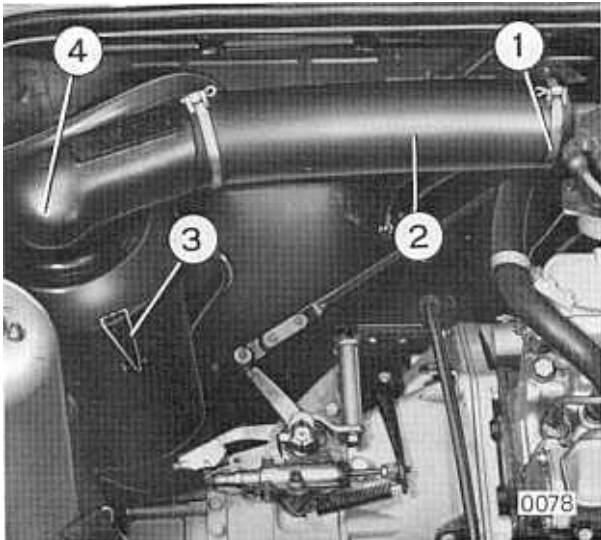

Fig. 01 2/9 Complete air cleaner

- Slacken the clamp (1), remove the tube (2), unhook the clips (3) and take off the cover (4) complete with cleaner element.
- Blow the element thoroughly with low air pressure; if it is worn or badly clogged, replace it.
- Refit in reverse order to the removal.

§ 01 2 1710

REMOVING AND REFITTING THE AIR CLEANER ASSY.

Fit the covers 88083051 and then *proceed as follows*:

Removal

- Operating within the engine compartment, remove the spare wheel (also remove the heat shield SCORPION only).
- Remove the air intake cover nuts and take the cover off, remove the air intake to carburettor securing nuts, remove the oil vapour breather pipes from the air intake, unhook the air cleaner cover securing clips, and then remove the cleaner cover complete with air intake.
- Remove the cleaner casing mounting bolts and lift off the casing.

Refitting

- Inspect the condition of the air intake gasket and replace if necessary.
- Refit all parts removed in the reverse order to the removal.

§ 01 2 1800

REMOVING AND REFITTING THE FUEL PUMP (ELECTROMECHANICAL)

Drive the car over the pit and then *proceed as follows*:

Removing

Operating from the pit:

- Remove the mounting bolt and take off the radiator grille.
- Remove the electric cable, slacken the clamps holding the inlet and take off the radiator grille.
- Remove the electric cable, slacken the clamps holding the inlet and outlet hoses to the pump, then remove the hoses.
- Unscrew the securing nuts and remove the fuel pump from its support.

Refitting

- Refit in the reverse order to the removal.

§ 01 2 1900

REMOVING AND REFITTING THE FUEL
CLEANER

Drive the car over the pit and then *proceed as follows*:

Removing

- Operating from the pit, remove the mounting bolts and take off the radiator grille.
- Remove the fuel inlet and outlet hoses from the cleaner
- Remove the securing nuts and lift the cleaner off its support bracket.

Refitting

- Refit in the reverse order to the removal.

§ 01 2 2200 Variant

CLEANING THE CARBURETTOR FLOAT
CHAMBER, BLOWING THE JETS AND SET-
TING THE SLOW RUNNING MECHANISM

Fit the covers 88083051 and then *proceed as follows*:

- Remove the float chamber cover as detailed in § 01 2 2250.

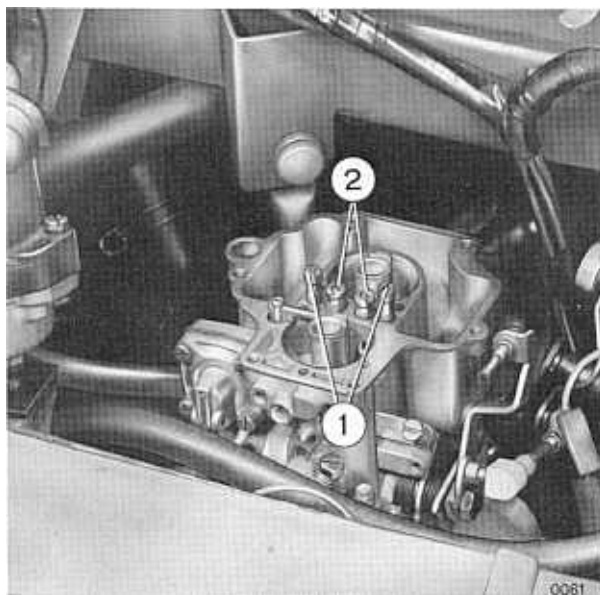
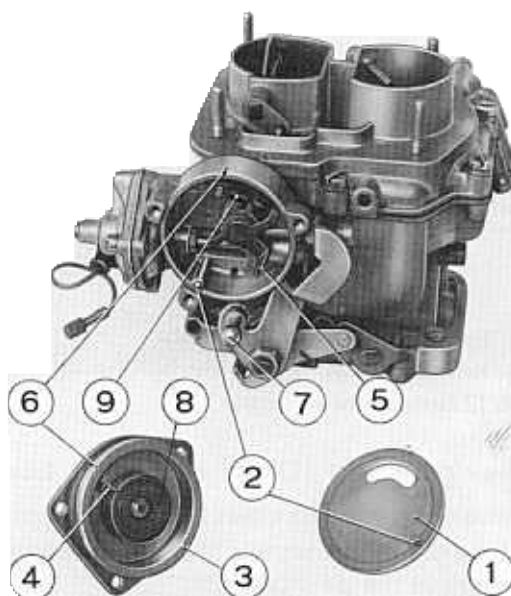

Fig. 01 2/10 Weber carburettor 34 DATR (200)

- Unscrew and remove the slow-running jets (1) and the main emulsifying tubes (2), the lower part of which carries the main jets.
- Blow the jets, inspect them and replace if worn. Also check that the stamped specification complies with that prescribed.
- Clean the fuel cleaner fitted to the float chamber cover.
- Clean the float chamber thoroughly.



0161

Fig. 01 2/11 Enrichment mechanism.

- Examine the gasket fitted to the float chamber cover for condition and replace it if necessary.
- Refit the slow-running jets, the main emulsifying tubes and the float chamber cover.
- Set the seal (1) so that marks (2) are in line, fit the coil housing (3), fitting the thermometric coil (4) to engage with the enricher control fork (5), then turn the coil housing in anti-clockwise direction until the marks (6) are in line.
- Complete the refitting of the remaining parts reversing the removal operations, then adjust the slow-running mechanism as described at 01 2 2300.

§ 01 2 2250 Variant

REMOVING REFITTING THE CARBURETTOR
FLOAT CHAMBER COVER (WEBER CARBU-
RETTOR)

Fit the covers 88083051 and then *proceed as follows*:

- Remove the cables from the water temperature gauge transmitter and the thermoswitch and put them on one side.

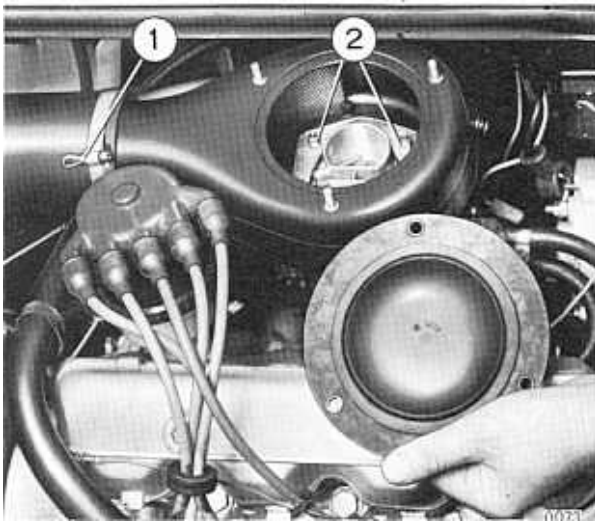

Fig. 01 2/12 Carburettor air intake

- Slacken the clamp (1) and remove the tube.
- Remove the air intake cover by removing nuts (2), take off the oil vapour breather tubes and then remove the air intake (3).

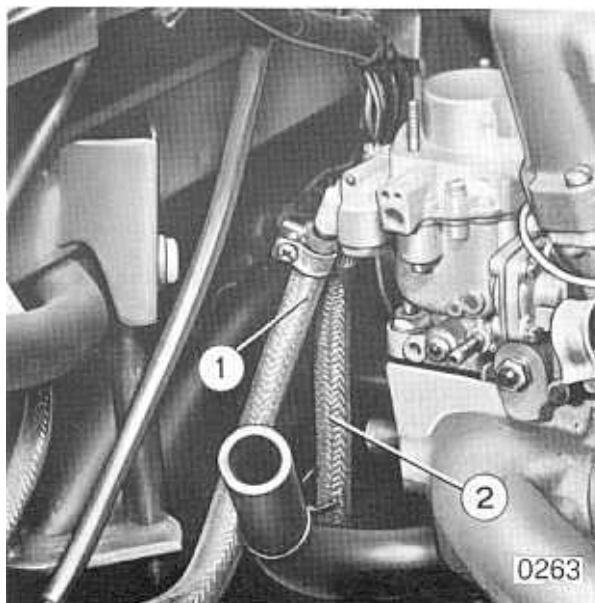

Fig. 01 2/13 - Carburettor seen from the fuel delivery and recovery hose side.

- Detach the fuel delivery and recovery hoses (1 and 2) and set them on one side.

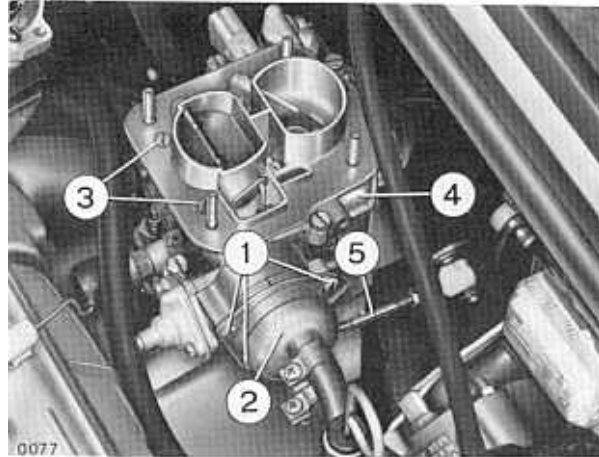

Fig. 01 2/14 - Carburettor seen from the automatic choke side.

- Remove the bolt (1), detach the box and set it on one side.
- Remove the bolts (3) and lift off the carburettor cover (4) (1).
- Refit by reversing the removal operations.

(1) To check fuel level, see 16 4 1150.

§ 01 2 2300 Variant

SETTING THE ENGINE SLOW-RUNNING ME-
CHANISM

Fit the covers 88083051 and then *proceed as follows*:

The slow-running mechanism should be set with the engine hot, turning and with the air cleaner fitted.

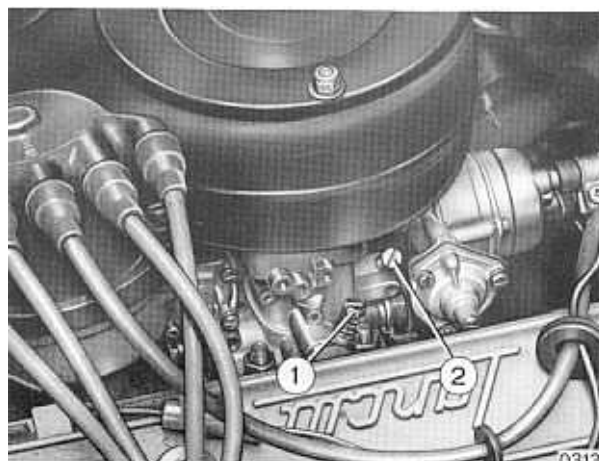

Fig. 01 2/15 - Slow-running setting bolts.

- First adjust the primary choke throttle by means of the bolt (2) until the engine is running steadily. Then adjust the bolt (1) until a mixture is found such that the engine turns quicker and more stably for that throttle setting; finally adjust the bolt (2) again until the engine is turning at the smoothest slow-running setting.

§ 01 2 3200 Va nt

REMOVING AND REFITTING THE CARBU-
RETTOR WITH ENGINE SLOW-RUNNING SET-
TING

Fit the covers 88083051 and then *proceed*
as follows:

Removing

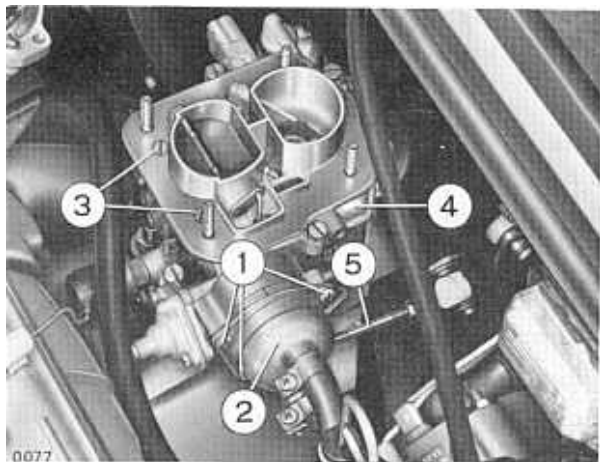
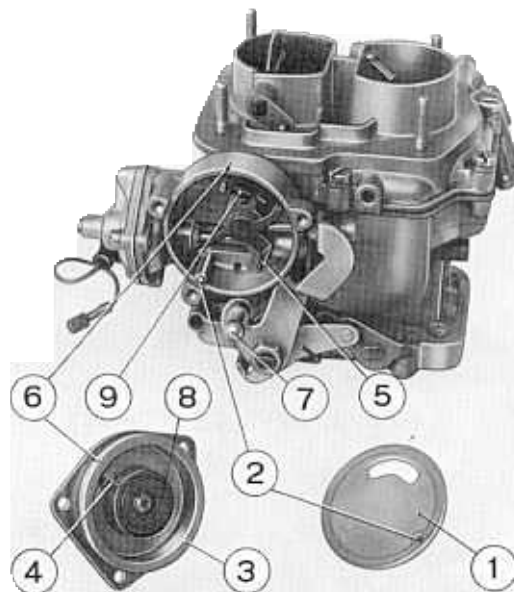

Fig. 01 2/16 - Carburettor seen from automatic choke side.

- Remove the float chamber cover as detailed in § 01 2 2250.
- Remove the rod (5) from the throttle control lever and the slow-running cut-off cable.
- Remove the mounting nuts (1) and take out the carburettor.

Refitting

- Refit the carburettor on the induction manifold.



0161

Fig. 01 2/17 - Enrichment mechanism

- Set the seal (1) so that marks (2) are in line, fit the coil housing (3), fitting the thermometric coil (4) to engage with the enricher control fork (5), then turn the coil housing in anti-clockwise direction until the marks (6) are in line.
- Complete the refitting of the remaining parts reversing the removal operations.
- When refitting has been completed, set the slow-running mechanism as described at 01 2 2300.

(1) For overhauling the carburettor see 01 4 1000.

§ 01 2 3710

REMOVING AND REFITTING THE CHOKE

Fit the covers 88083051 and then *proceed*
as follows:

Removing

- Remove the air intake, the fuel delivery and recovery hoses and the water pipes from the automatic choke.
- Remove the carburettor cover complete with choke after removing the securing bolts.

At the bench

- Remove the bolt (1), take off the cover (2), remove the bolts (3) and detach the coil housing (4).

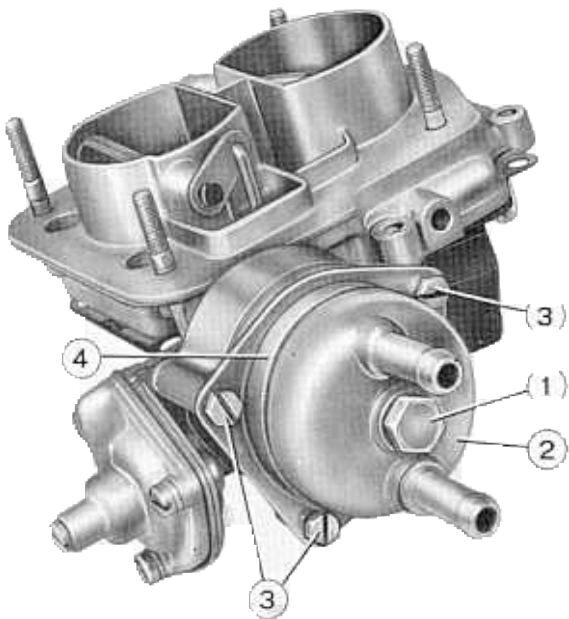

0314

Fig. 01 2/18 - Float chamber cover complete with choke

- Remove the bolts securing the choke control box to the carburettor cover, then remove the box.

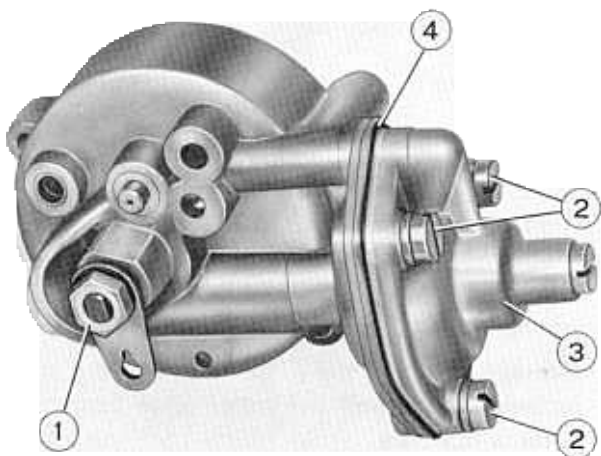

0315

Fig. 01 2/19 - Choke control.

- Remove the nut (1), take off the choke spindle, remove the bolts (2) and take off the float chamber cover (3) and remove the diaphragm (4).
- Check the various parts visually, particularly the choke spindle spring and the coil, and replace any parts out of shape or broken.

Refitting

- Refit by reversing the removal operations

§ 01 2 3800

REMOVING AND REFITTING THE ACCELERATOR CONTROL CABLE

Drive the car over the pit, fit the covers 88083051 and *proceed as follows*:

Removing

- Remove the spare wheel from the engine compartment (also remove the heat shield SCORPION only).
- Slacken the clamp holding the cable to the idler lever.
- Working inside the car, remove the mounting bolts and take out the kick panel on the left hand side of the central cabinet.
- Remove the cotter key and pull out the accelerator control cable.
- Operating from below the car, remove the mounting bolts and take off the rear grille.
- Remove the sheath steering column clip and the circlip securing the sheath to the idler lever support bracket, then remove the sheath.

Refitting

- Refit in the reverse order to the removal.
- When the operation is completed, check that the primary choke throttle valve is fully open when the accelerator pedal is fully depressed.

EHAUST SYSTEM

§ 01 2 4300 Variant

REMOVING AND REFITTING THE EXHAUST PIPE ASSEMBLY

Drive the car over the pit and then *proceed as follows*:

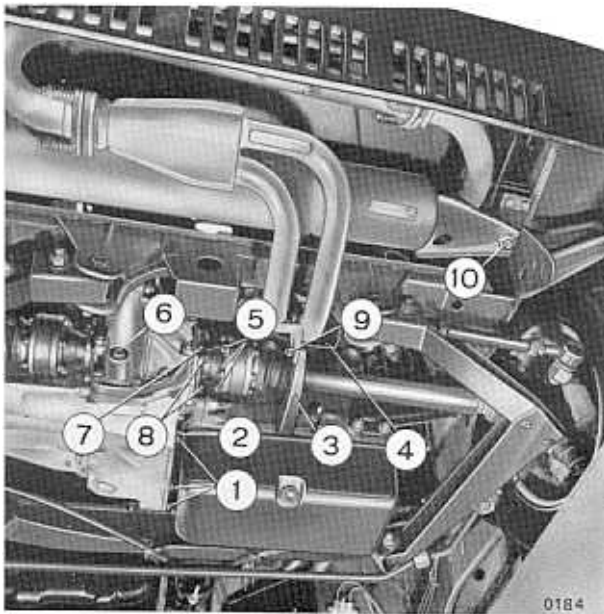

Fig. 01 2/20 - View of the engine from below the car

Removing

- Remove nut (9), remove the mounting bolts and take off the heat shield (4).
- Remove the nuts securing the exhaust piping to the exhaust manifold, then remove the bolts (10) and take out the complete assembly.

At the bench

- Remove the nuts (1), separate the intermediate pipe (2) from the front pipe (3) and the silencer (4) and replace worn parts.

Refitting

- Refit in reverse order to the removal

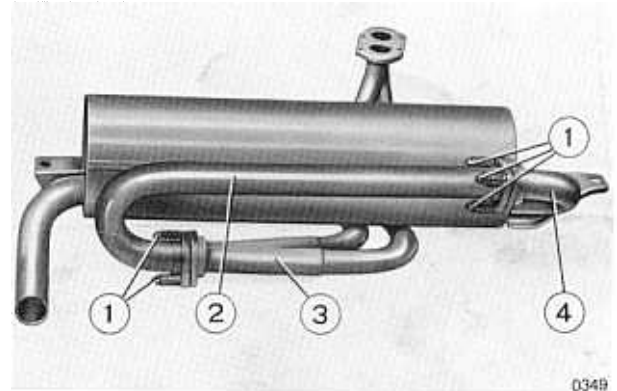

Fig. 01 2/21 - Complete exhaust pipe assembly.

COOLING SYSTEM

§ 01 2 4650

DRAINING REFILLING DEAERATING THE COOLING SYSTEM

Drive the car over the pit, fit the covers 88083051 and *proceed as follows:*

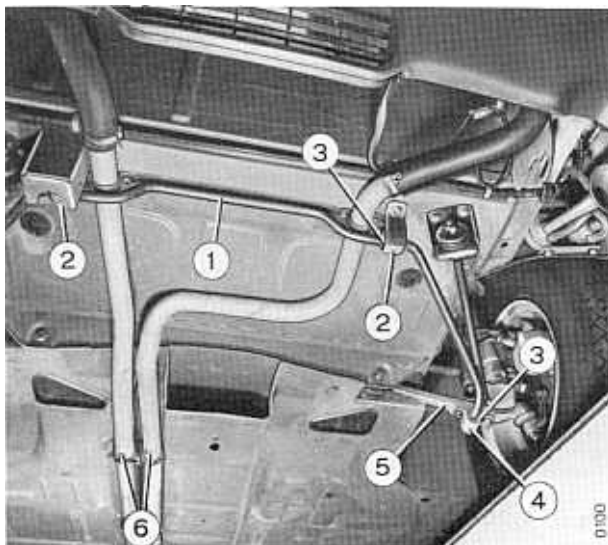

Fig. 01 2/22 - Coolant circuit drain plugs

- Working from under the car, remove the plugs (6) and drain the coolant into a container before replacing the plugs.

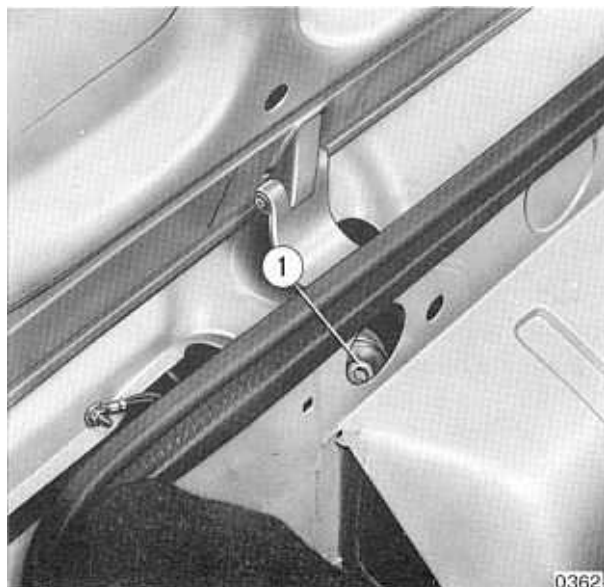

Fig. 01 2/23 - Coolant drain screw on radiator

- Working inside the engine compartment, fill the radiator with coolant and start the engine.
- Working in the boot, loosen the drain screw (1); as soon as coolant starts to drip out, tighten the drain screw definitively.
- When the operation is completed, top up the coolant level.

§ 01 2 4700

REMOVING AND REFITTING THE COOLANT RADIATOR

Drive the car over the pit, fit the covers 88083051, drain off the coolant as described at 01 2 4650, and *proceed as follows:*

Removing

- Operating from the pit, remove mounting bolts and nuts and take off the shroud between tunnel and air inlet.

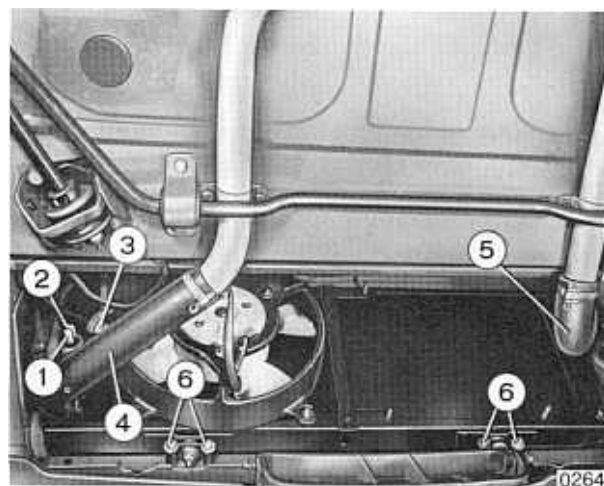

Fig. 01 2/24 - Radiator seen from below the car.

- Remove the cables (1 and 2) from the fan control switch.
- Remove the fan motor leads from the connection (3).
- Loosen the clamps and remove the couplings (4 and 5) from the radiator.
- Remove the bolts (6) and take out the radiator complete with fan.

Refitting

- Refit in the reverse order to the removal.
- Complete the operation by refilling and deaerating the cooling circuit as described in 01 2 4650.

§ 01 2 4800

REMOVING AND REFITTING THE COOLANT PUMP

Drive the car over the pit, fit the covers 88083051, drain off the coolant as described at 01 2 4650, and *proceed as follows*:

Removing

- Operating in the engine compartment, loosen the bolts securing the sheave to the pump, loosen the alternator drive belt, completely remove the securing bolts and remove the sheave.
- Remove the clamping nuts and detach the coolant inlet pipe, setting it on one side.

- Raise the car at the sump by means of a hydraulic jack fitted with bracket 88097827, taking care to set a block of wood between the jack and the sump beforehand.

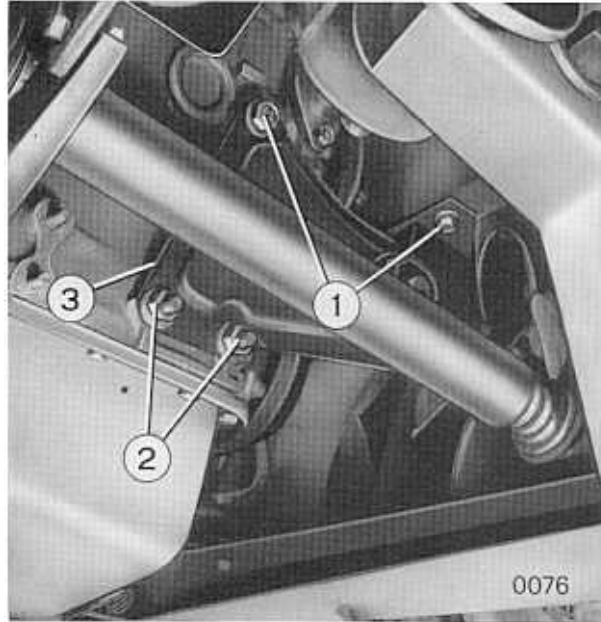

Fig. 01 2/26 - Front mounting bracket

- Remove the bolts (1) and the nuts (2) and take off the mounting bracket (3).
- Remove the bolts securing the pump to the crankcase and lift off the pump together with the sheave.

Refitting

- Refit in the reverse order to the removal.
- Top up the coolant and deaerate as described at 01 2 4650.
- When the operation is completed, check that there are no leaks in the cooling circuit.

N.B. - The complete pump assembly only is supplied as a spare.

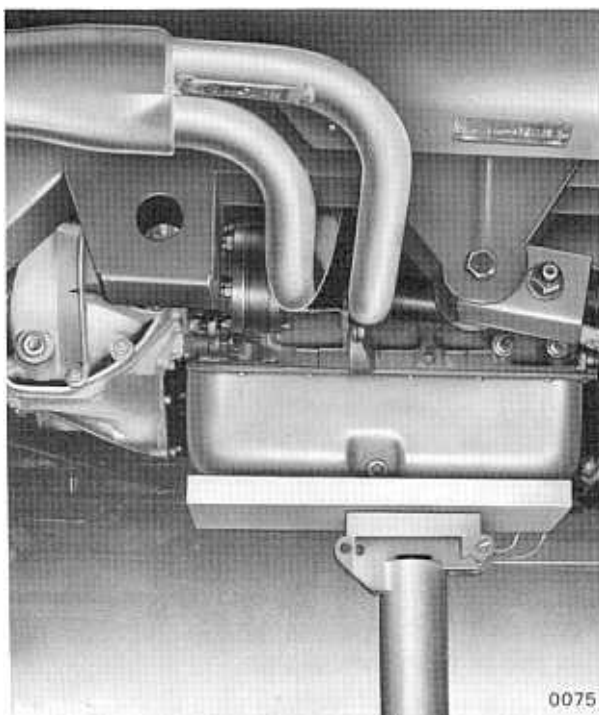

Fig. 01 2/25 - Setting of block below oil sump.

SPECIAL TOOLS REQUIRED

- 88097827 - Bracket.

§ 01 2 4900

REMOVING AND REFITTING THE COOLANT
BLENDER THERMOSTAT

Drive the car over the pit, fit the covers 88083051, drain the coolant as described at 01 2 4650, and *proceed as follows*:

Removing

- Loosen the clamps (3), take off the couplings and remove the thermostat (4).

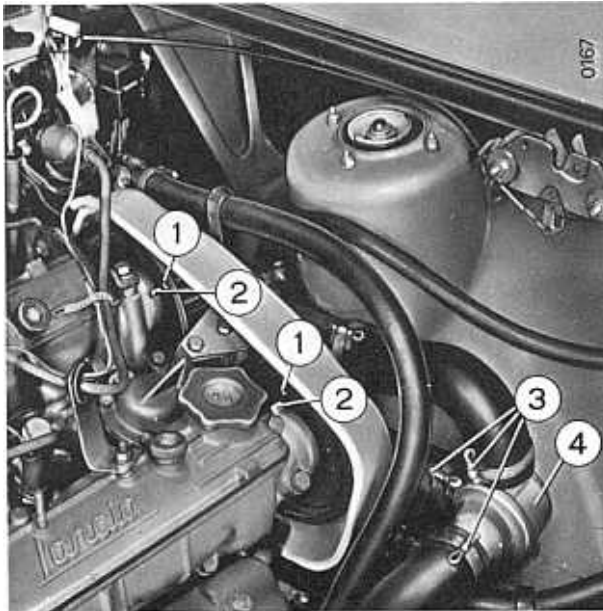

Fig. 01 2/27 - Blender thermostat

Refitting

- Refit in the reverse order to the removal.
- Top up the coolant level and then deaerate as described at 01 2 4650.

§ 01 2 5000

REMOVING AND REFITTING THE MOTOR
DRIVEN FAN

Drive the car over the pit and *proceed as follows*:

Removing

- Operating from the pit, remove mounting bolts and nuts and take off the shroud between the tunnel and air inlet.
- Remove the cables from the fan control switch.
- Remove the mounting nuts and take off the shroud complete with fan motor.

At the bench

- Remove the nuts holding the motor to the shroud, then remove the motor and fan.
- Undo the nut and remove the fan from the motor.
- Replace any damaged parts and refit all parts removed.

Refitting

Refit in the reverse order to the removal

§ 01 2 5030

CHECKING THE THERMOSWITCH, SOLE-
NOID SWITCH AND MOTOR DRIVEN FAN

Drive the car over the pit and *proceed as follows*:

- Operating from the pit: detach the cables from the thermoswitch, connect them together, then insert the ignition key. If the motor driven fan comes on, the thermoswitch is faulty and should be replaced. If it does not, proceed as follows to find out whether the fault depends on the solenoid switch or the motor driven fan:
 - Reconnect the cables to the thermoswitch.
 - Connect the positive terminal of the battery to the fan input. If the fan comes on, the fault is caused by the solenoid control switch, if not, the fan itself is faulty (1).

(1) To remove the thermoswitch see 01 2 510; to remove the solenoid switch see 14 2 4500; to remove the motor driven fan see 01 2 5000.

§ 01 2 5100

REMOVING AND REFITTING THE MOTOR
DRIVEN FAN CONTROL THERMOSWITCH

Drive the car over the pit, drain off the coolant as described at 01 2 4650 and *proceed as follows*:

Removing

- Disconnect the thermoswitch wires.
- Unscrew the thermoswitch from the radiator.

Refitting

- Refit in reverse order to the removal operation, taking care to fit a new thermoswitch washer.
- Top up the coolant level and deaerate the circuit.

§ 01 2 5110

CHECKING WORKING CONDITION OF COOLANT
TEMPERATURE GAUGE - TRANSMITTER
AND MOTOR DRIVEN FAN CUT-IN AND
CUT-OUT TEMPERATURE

Drive the car over the pit, fit the covers 88083051 and *proceed as follows*:

- Partially drain coolant from the engine block.

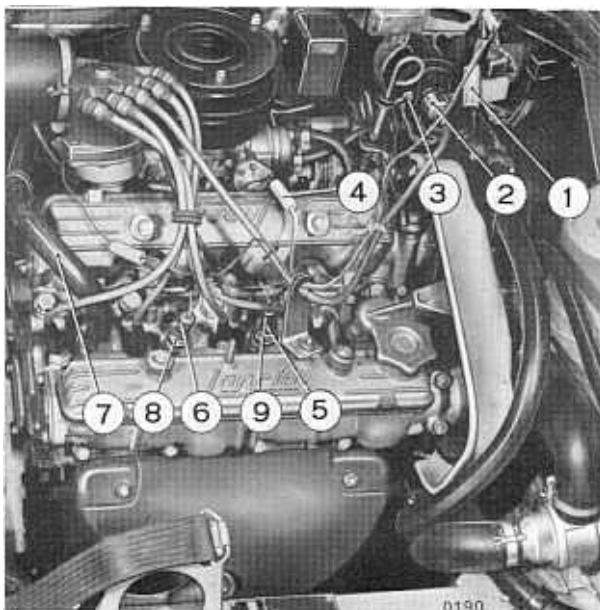
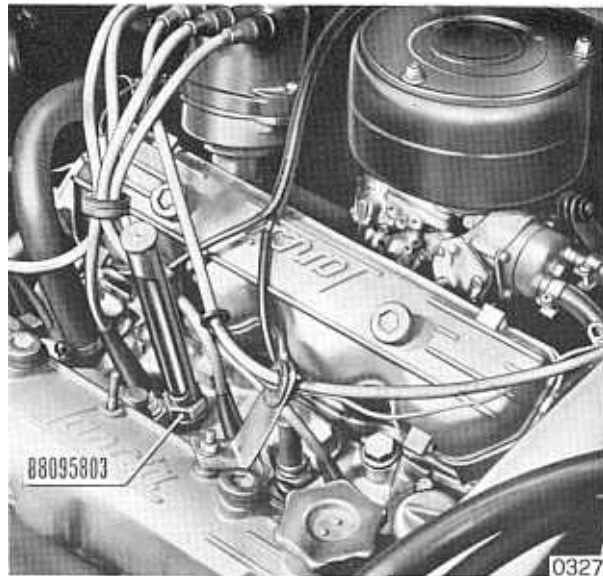

Fig. 01 2/28 - Transmitter and thermoswitch

- Working in the engine compartment, disconnect transmitter (8) and switch (9) wires and earth them.
- Disconnect the oil low pressure warning light switch wire and make sure that it cannot be earthed.
- Switch on the ignition and check whether the coolant temperature gauge hand goes to the bottom of the scale and the engine overheating warning light stays on. (If one or neither of these conditions occurs the temperature gauge or the warning light bulb or both are faulty and need replacement).

Checking the motor driven fan cut-in and cut-out temperature

Fig. 01 2/29 - Positioning of temperature gauge
88095803

- Remove the transmitter (8) and fit temperature gauge 88095803 in its place; then reconnect the thermoswitch (9) wire.
- Top up the coolant level, start the engine and let it run till the right temperature is reached.
- Check the reading on the test temperature gauge and see whether the fan cuts in and cuts out at the prescribed temperatures (1).
- With the engine running, disconnect a wire from the thermoswitch to stop it working and check whether the engine overheating warning light on the car instrument panel comes on at the right temperature (2).

- Partly drain coolant from the engine block.
- Remove the test temperature gauge and refit the transmitter.
- Reconnect disconnected wires.
- Top up the coolant level and deaerate the circuit.

SPECIAL TOOLING REQUIRED

- 88095803 Test temperature gauge.

(1) Should the motor driven fan fail to cut in and cut out at the recommended temperatures, the thermostich needs replacing (see 01 2 5100).

(2) Should the warning light fail to come on at the prescribed temperature, the switch (2) needs replacing.

LUBRICATION SYSTEM

§ 01 2 5600

CHECKING THE OIL PRESSURE

Fit the covers 88083051 and *proceed as follows*:

Removing

- Operating from the pit remove the floor pan
- Disconnect the cables from the oil pressure gauge transmitter and from the oil pressure switch and then remove them.
- In place of the transmitter and oil pressure switch, fit the flexible probe 88015464 together with pressure gauge 88095453 and temperature gauge 88095804.

From above the car:

- Start the engine and let it run until the temperature of the coolant has gone up to about 85-90°C and the temperature of the oil to 85°C, then check that pressure gauge 88095453 is showing the correct pressure.

Working below the car:

- When the test is over, remove the pressure and temperature gauges and the respective flexible probes.
- Refit the oil pressure transmitter and switch. When this operation has been completed, start the engine and check that there are no oil leaks.

TOOLS REQUIRED

- 88015464 - Flexible probe
- 88095453 - Pressure gauge
- 88095804 - Temperature gauge

§ 01 2 5700

REMOVING AND REFITTING THE OIL PUMP

Drive the car over the pit, fit the covers 88083051 and *proceed as follows*:

Removing

- Working under the car, drain the oil from the engine into an appropriate container and refit the plug.

- Remove the bolts holding the flywheel guard to the gearbox and lift it off.
- Remove the mounting bolts and take the sump off the crankcase.
- Remove the bolts holding the oil pump to the crankcase and take it off (1).

Refitting

- Clean the mating surfaces and fit a new seal, refit the oil pump securing the bolts at the torque loading prescribed.
- Fit a new gasket, refit the oil pump and complete the refitting of the remaining parts, working in reverse order to the removal and tightening the bolts to the prescribed torque loading.

(1) To overhaul the oil pump, see 01 4 2500.

SPECIAL TOOLS REQUIRED

- 88091134 } Torque spanners
- 88091135 }

§ 01 2 6000

REMOVING AND REFITTING THE OIL FILTER BASE TO RENEW THE GASKET

Drive the car over the pit, fit the covers 88083051 and *proceed as follows*:

Removing

- Remove the alternator as described at 14 2 7200.
- Working under the car, remove the guard.
- Disconnect the cables from the oil pressure gauge transmitter and the pressure switch.
- Remove the mounting nuts and lift off the base.

Refitting

- Fit a new base gasket and then refit the parts in the reverse order to the removal.
- Refit the alternator as detailed at 14 2 7200.
- Refit the other components, start the engine and check for oil leaks from the filter base.

VALVE GEAR

§ 01 2 6500

CHECKING THE TAPPET CLEARANCE

Fit the covers 88083051 and *proceed as follows*:

- Disconnect the cables from the spark plugs and those from the high temperature warning light switch and lay them to the side.
- Remove both tappet covers.
- Turn the cylinders 1, 3, 4 and 2 one by one to the expansion stroke (1) and, using the feeler gauge 88095770, check the clearance of the intake and exhaust valves of each cylinder. It is a good idea to note down the values.

Example:

The 0.40 mm blade goes but the 0.45 mm blade does not; clearance will therefore be greater than 0.40 mm and less than 0.45 mm. For more precise measurement, add to the blade that goes (0.40 mm) a feeler gauge of 0.03 mm; if the combination goes the clearance value lies between 0.40 and 0.43 mm, if it does not clear, it lies between 0.43 and 0.45 mm.

In the former case 0.42 mm and in the latter 0.44 mm will be considered as the effective values.

(1) The cylinder is in the expansion stroke when the camshaft lobe that controls the tappet is pointing upwards.

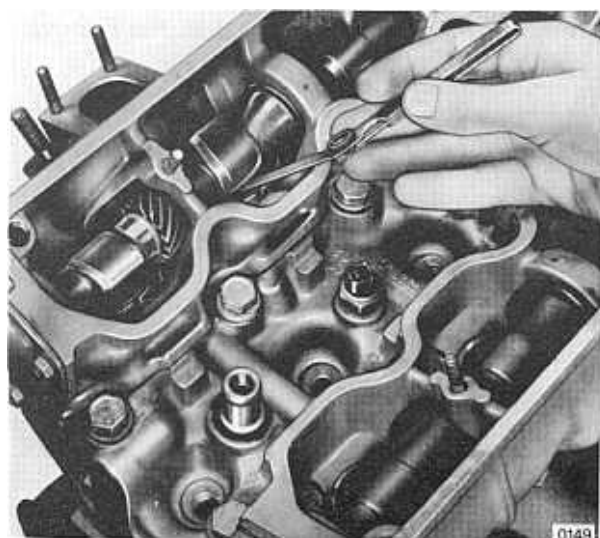

Fig. 01 2/30 - Checking tappet clearance

- Once the checking is over and providing the measured clearance corresponds to standard, refit all the parts removed in the reverse order to the removal. Otherwise, reset tappet clearance as described at 01 2 6600.

SPECIAL TOOLS REQUIRED

- 88095770 - Feeler gauge

§ 01 2 6600

SETTING VALVE TAPPET CLEARANCE

Fit the covers 88083051, check valve tappet clearance as described at 01 2 6500 and then proceed as follows:

- Remove the mounting nut and take off the ignition distributor.
- Turn the crankshaft to the point where the camshaft lobe that controls the tappet being controlled is turned upwards and perpendicular to the shim, then locate one of the tappet slots as shown in the figure below.

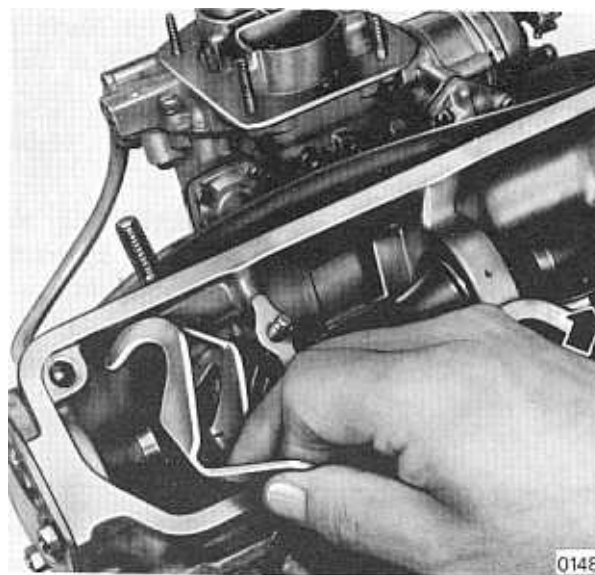

Fig. 01 2/31 - Using tool 88013036 to remove the shim

- Turn the crankshaft further so that the valve controlled by the tappet to be adjusted is fully open; fit the tool 88013036 and turn the crankshaft until the lobe releases the tappet and tool 88013036 keeps the tappet locked in the open valve position.

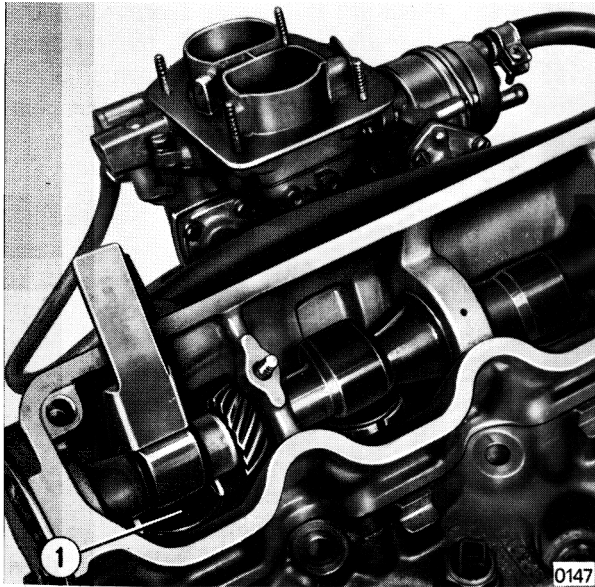

Fig. 01 2/32 Locking tappet with tool 88013036 to remove shim

- Apply air pressure to the tappet slot and remove the shim (1) using the pliers 88013038.
- Check the thickness of the shim just removed by using the dial gauge and the rest surface supplied with the trolley 88013055, or the outfit 88013040.

To measure the thickness of the shim to be employed, proceed as follows:

- Add the thickness of the removed shim to the measured valve clearance; then subtract the clearance specified for the valve in question.

The difference represents the thickness of the shim to be fitted (see table).

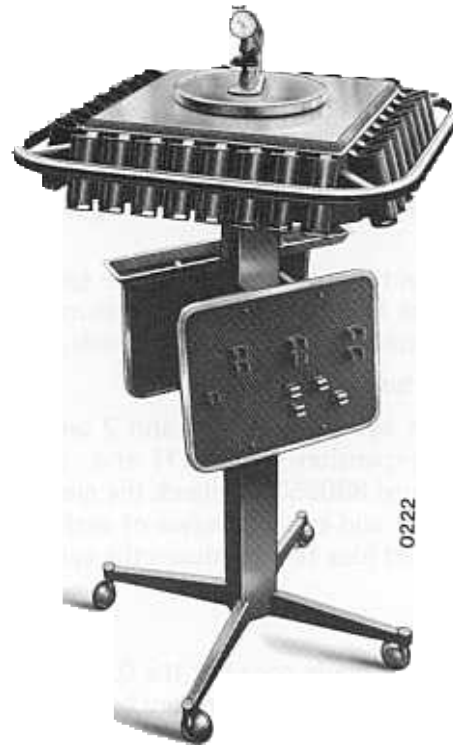

Fig. 01 2/33 Trolley for valve tappet adjusting shims

- Fit the new shim using pliers 88013038, turn the crankshaft until the lobe fully depresses the tappet in question, then withdraw tool 88013036.
- Proceed in similar fashion when setting the remaining tappets.
- When setting is completed, refit all the parts removed in the reverse order to the removal.

Clearance gauged	Thickness of shim removed mm.	Clearance plus thickness of shim removed mm.	Specified clearance	Calculation to determine thickness of new shim	Thickness of shim to be fitted mm.
Intake valve 0,36	3,65	4,01	0,45	$\begin{array}{r} 4,01 - \\ \underline{0,45} = \\ 3,56 \end{array}$	3,55
Exhaust valve 0,49	4,20	4,69	0,60	$\begin{array}{r} 4,69 - \\ \underline{0,60} = \\ 4,09 \end{array}$	4,10

SPECIAL TOOLS REQUIRED

- 88013036 - Shim replacement tool
- 88013038 - Pliers
- 88013055 - Tappet shims trolley.

§ 01 2 6800

CHECKING AND SETTING THE VALVE GEAR TIMING (including checking ignition timing)

Drive the car over the pit, fit the covers 88083051, drain off the coolant as described at 01 2 4650 and *proceed as follows*:

Removing

- Remove the spare wheel from the engine compartment (also remove the heat shield SCORPION only).

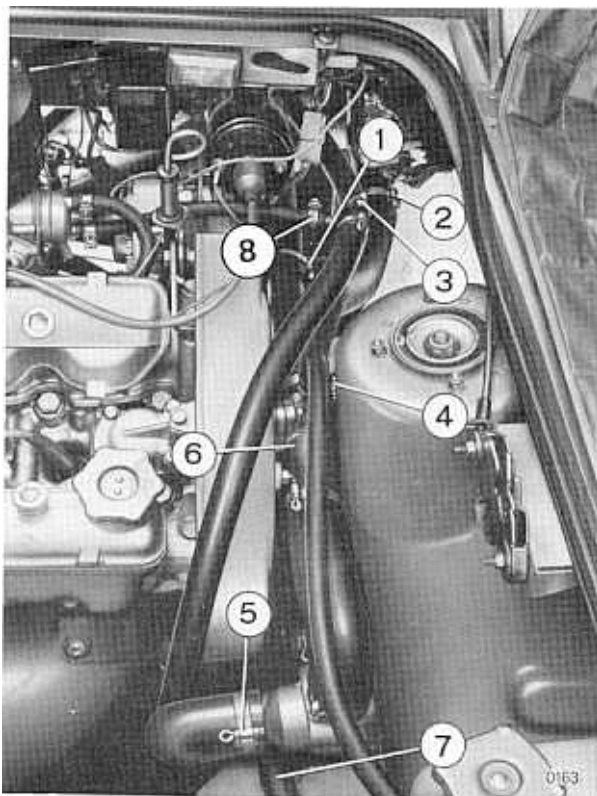

Fig. 01 2/34 - Coolant piping

- Loosen the clamps (1,2,3,4,5 and 8), remove the connector (6) together with couplings and thermostat.
- Loosen the water pump and alternator belt stretcher and take off the belt.

Remove the mounting bolts and take off the valve gear cover.

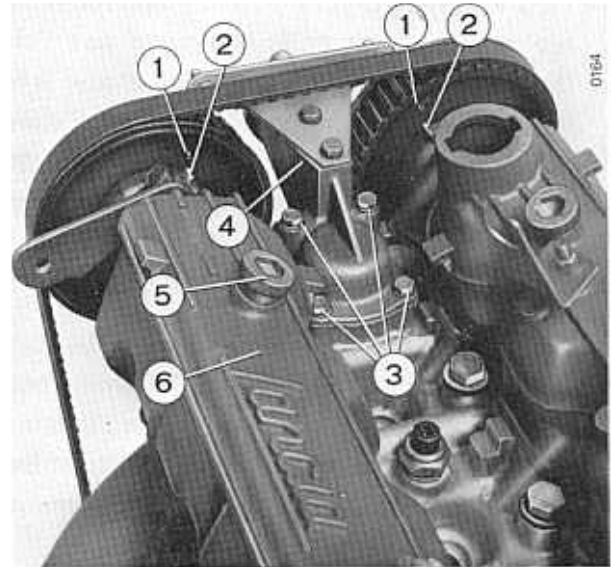

Fig. 01 2/35 - View of engine from above

- Remove the screws (3) and the pipe union (4)
- Turn the crankshaft in working direction (clockwise) until the holes (1) are aligned with the markings (2).

Note Use tool 88013039 SCORPION only.

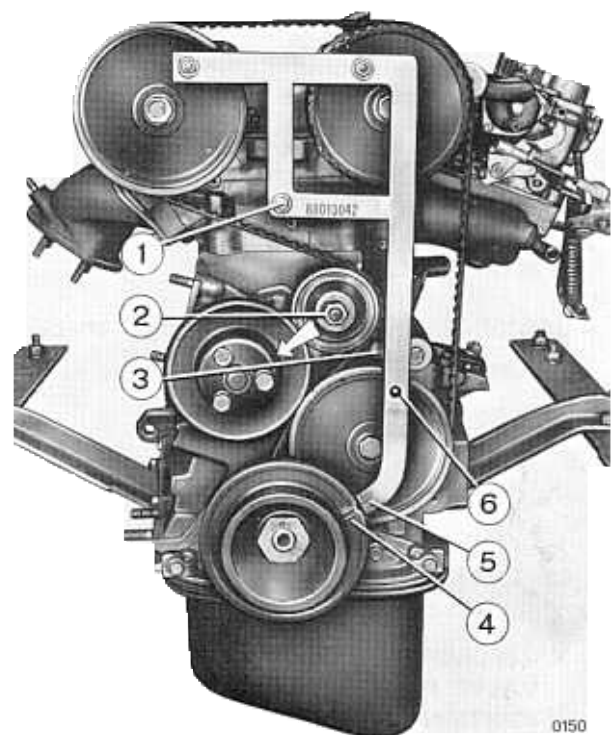

Fig. 01 2/36 - Positioning of timing checking fixture.

- Fit the timing checking fixture 88013042 to the camshaft gear holes and make sure that the marking (5) on the crankshaft sheave is in line with the marking (4) on the fixture 88013042. If it is, the bore (3) should fit into the hole in the ancillary unit drive shaft gear. Should any of the above markings be misaligned, *proceed as follows*:
- Remove the fixture 88013042, loosen the nut (2) and the bolt (1) securing the timing belt stretcher, lever the stretcher in the direction of the arrow and at the same time tighten the nut (2) to eliminate belt tension; then remove the belt from the gears.
- Align the gear in question with the fixed reference marking, refit the fixture 88013042 and then refit the timing belt.
- Loosen the nut (2) so as to tighten the belt again, then tighten the bolt (1) and the nut (2), remove the fixture 88013042 and turn the crankshaft a few times in working direction (clockwise) to enable the belt to settle.
- Use the fixture to check that the markings coincide.
- If necessary, check the ignition timing as described at 01 2 0300.
- Refit all parts in the reverse order to the removal, fill up with coolant and deaerate as described at 01 2 4550.

SPECIAL TOOLS REQUIRED

- 88013042 - Valve gear timing checking fixture
- 88015150 - 12 Volt timing lamp

§ 01 2 6950

REPLACING THE TIMING BELT INCLUDING VALVE GEAR TIMING AND CHECKING THE IGNITION TIMING

Drive the car over the pit, fit the cover

88083051, drain off the coolant as described at 01 2 4650 and *proceed as follows*:

- Remove the spare wheel from the engine compartment.

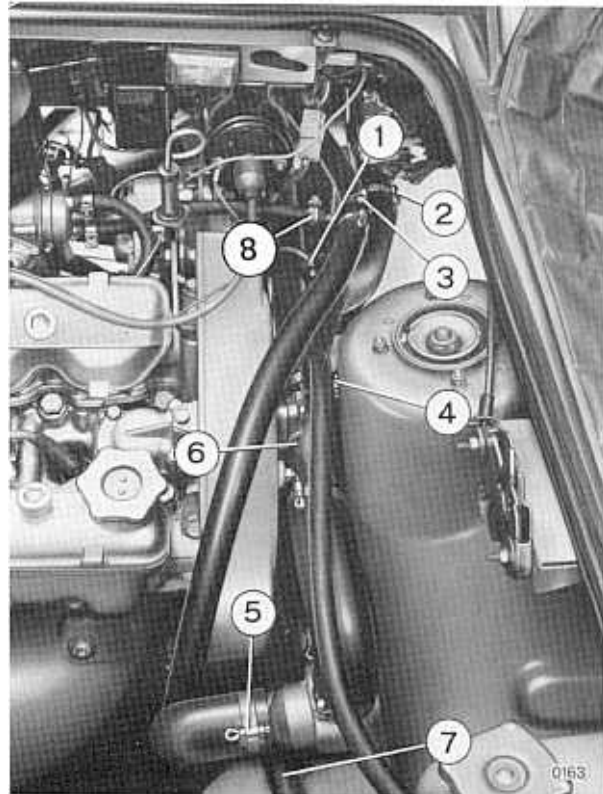

Fig. 01 2/37 - Coolant piping

- Loosen the clamps (1, 2, 3, 4, 5 and 8), remove the connector (6) together with couplings and thermostat.
- Loosen the alternator belt stretcher and remove the belt, coolant pump and alternator.
- Remove the mounting bolts and take off the valve gear cover.

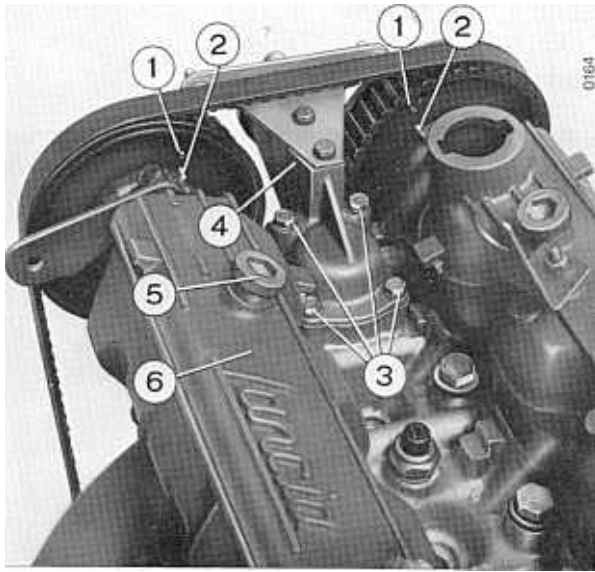

Fig. 01 2/38 - View of engine from above.

Note: Use tool 88023039 SCORPION only.

- Remove the bolts (3) and the pipe union (4).
- Turn the crankshaft in working direction (clockwise) until the holes (1) are aligned with the markings (2).
- Loosen timing belt stretcher as described at 01 2 6800.
- Remove the timing belt.
- Fit the timing checking fixture 88013042 and time the valve gear, then refit the timing belt as described at 01 2 6800.
- Check and reset the ignition timing, if necessary, as described at 01 0300.
- Refit and tighten the alternator and coolant pump drive belt.
- Refit all the remaining parts in the reverse order to the removal.
- Fill up with coolant and deaerate as described at 01 2 4650.

SPECIAL TOOLS REQUIRED

- 88013042 - Valve gear timing checking fixture.
- 88015150 - 12 Volt timing lamp.

§ 01 2 7010

REMOVING—REFITTING ONE CAMSHAFT HOUSING (INTAKE SIDE), CHECKING VALVE TAPPETS CLEARANCE

(Removing-refitting timing belt excluded)

Drive the car over the pit, fit the covers 88083051, remove the timing belt as described at 01 2 6800, and *proceed as follows*:

Removing

- Remove the low voltage ignition distributor input cable, and the spark plug cables, then remove the bolts securing the cap to the distributor and remove the cap with cables.
- Remove the cables from the water temperature transmitter and the thermostich together with the slow running cut-off cable and lay them aside.

Remove the upper bracket securing the alternator.

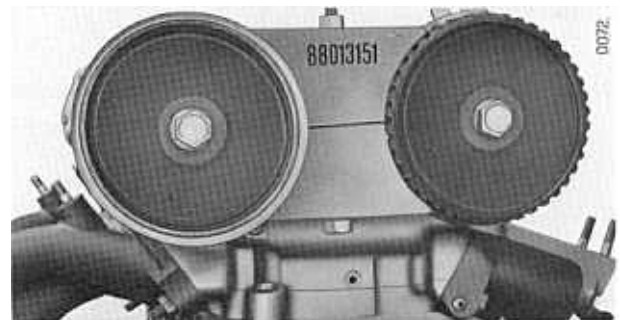

Fig. 01 2/39 Camshaft gear locking fixture 88013151.

- Fit camshaft gear locking fixture 88013151.
- Loosen the mounting bolt of the camshaft gear of the housing in question, then remove fixture 88013151.
- Remove the valve tappet cover fixing nuts and remove the covers from both housings.
- Remove the bolts securing the upper housing to the cylinder head and remove it along with the tappets (1).
- Remove the tappets from the housing and set them aside so that each can be readily refitted in the seat from which it has been removed.

Refitting

Check that no score marks are present on tappets and seats of camshaft housing and make sure that each tappet is put back in its original seat.

- Carefully clean rest surfaces of camshaft housing and cylinder head.
- Fit the new upper housing gasket after moistening with engine oil.
- Refit the upper housing in the cylinder head and torque tighten the mounting nuts.
- Fit the fixture 88013151 to lock camshaft gears then torque tighten the camshaft gear mounting bolt of the housing in question and remove the fixture 88013151.

Refit the timing belt and set the valve gear timing as described at 01 2 6800.

- Check valve tappet clearance as described at 01 2 6500 (2)
- Refit the tappet covers complete with gaskets and refit the other parts in reverse order to the removal.

N.B. – The operations marked with an asterisk are not necessary when the only purpose of the repair is to replace the housing seal.

SPECIAL TOOLS REQUIRED

- 88013151 - Camshaft gear locking fixture
- 88011135 - Torque spanner
- 88095770 - Feeler gauge
- 88013036 - Shim replacement tool

(1) To overhaul camshaft housings see 01 4 3400.

(2) To adjust valve tappet clearance see 01 2 6600.

§ 01 2 7300

REMOVING AND REFITTING THE TIMING BELT STRETCHER ASSY
(Excluding removing and refitting the timing belt)

Fit the covers 88083051, remove the timing belt (as described at 01 2 6800) and

proceed as follows:

Removing

Fig. 01 2/40 - Timing belt stretcher assembly

- Remove the bolts (1 and 2) and take off the spring.
- Check the spring for load, proceeding as described at 01 3 0520.
- Remove the nut (3) and the support complete with stretcher ring.

If the stretcher ring has to be replaced, take out the ring bearing.

Refitting

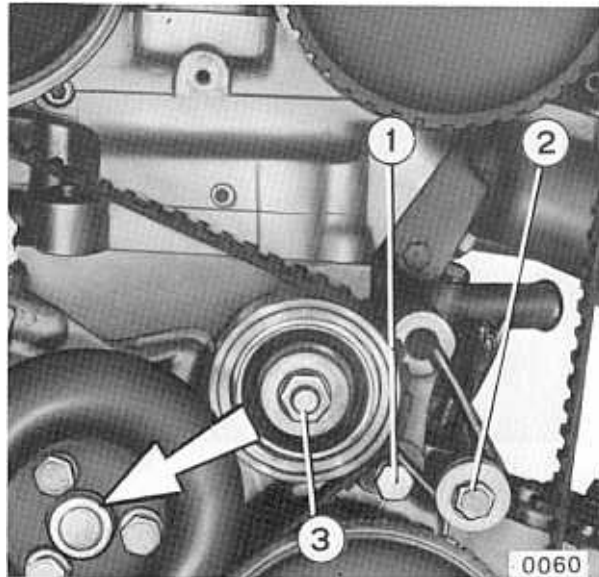
- Refit the belt stretcher support and spring, tighten the spring mounting bolt (1) and leave bolt (2) and nut (3) slack; push the stretcher ring in the direction of the arrow and then partially tighten the bolt (2) and the nut (3).
- Refit the timing belt and carry out the relative timing control operation as described at 01 2 6800.

§ 01 2 7500

REMOVING AND REFITTING THE CAMSHAFT DRIVE GEARS, ANCILLARY UNITS SHAFT DRIVE GEAR AND TIMING BELT DRIVE GEAR
(excluding removing and refitting the timing belt)

Drive the car over the pit, fit the covers

88083051, remove the timing belt, as described at 01 2 6800, and *proceed as follows*:



Fig. 01 2/41 - Positioning the stand

Removing

- Slacken the rear right wheel securing bolts.
- Working in the pit, raise the car with the hydraulic jack fitted with bracket 88097827 and set it on the stand 88097120 as shown in the figure, then remove the loosened wheel.

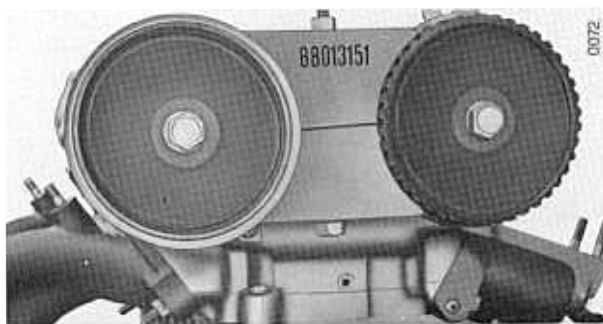

Fig. 01 2/42 - Retainer 88013151 for locking camshaft drive gears.

- Working in the engine compartment:
- Lock the camshaft drive gears using the retainer 88013151 and loosen the mounting bolts.
- Remove the retainer 88013151, take out the bolts and remove the camshaft gears.
- Working under the car:

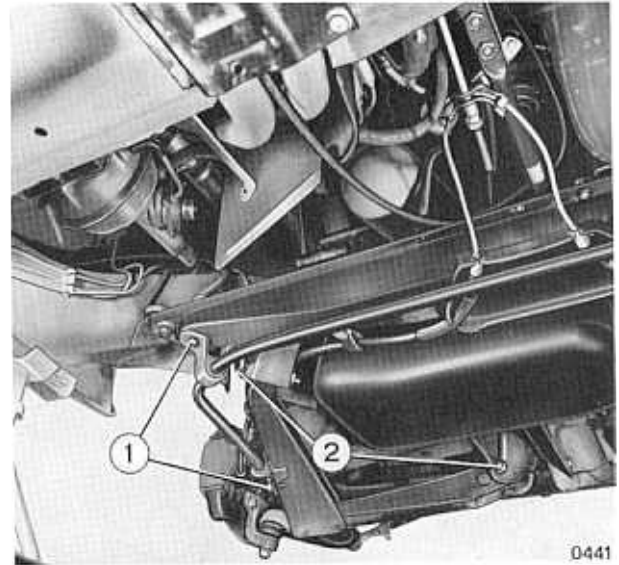

Fig. 01 2/43 - Right rear arm.

Remove the bolts (1 and 2) securing the stabilizer bar to the arm, remove the bolts (3) and pull off the arm (4).

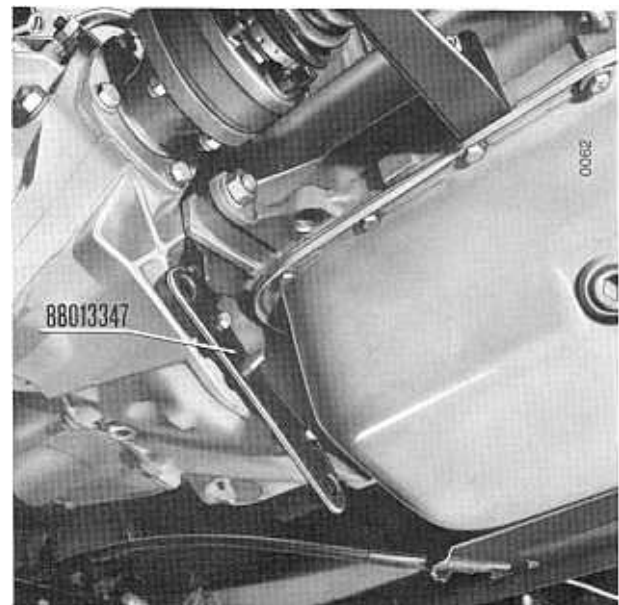

Fig. 01 2/44 - Positioning of retainer 88013347 for locking crankshaft.

- Remove the flywheel guard and fit the retainer 88013347 to lock the crankshaft.
- Using the spanner 88091231, take off the nut holding the sheave to the crankshaft and then lift off the sheave.

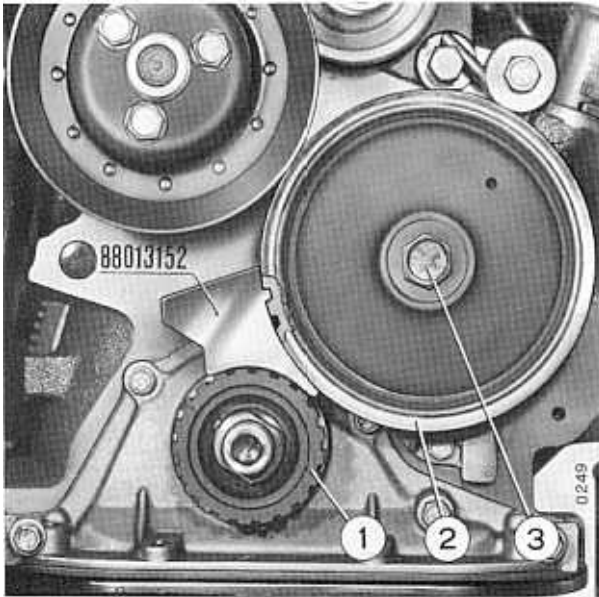

Fig. 01 2/45 - Retainer 88013152 for locking the ancillary units shaft drive gear.

- Position the retainer 88013152 between the timing belt drive gear (1) and the gear (2), remove the bolt (3), take off the retainer 88013152 and remove the gear (1).

Refitting

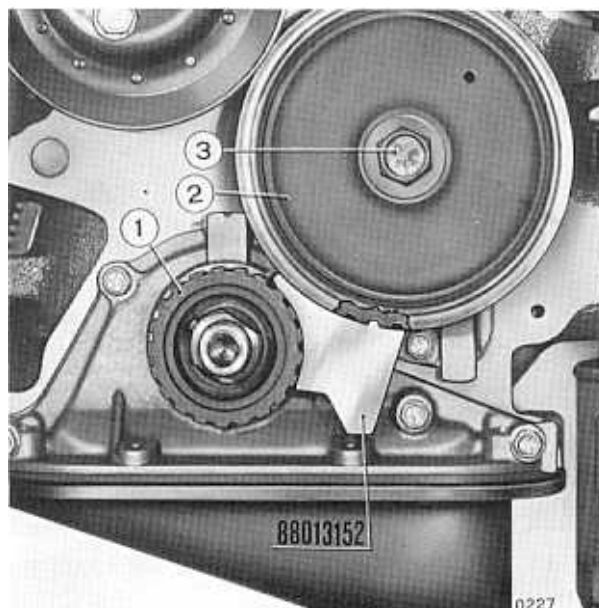

Fig. 01 2/46 - Fitting of retainer 88013152 to tighten the ancillary units drive gear mounting bolt.

- Refit the timing belt drive gear (1) to the crankshaft and the gear (2) to the ancillary units drive shaft; then position retainer 88013152 as shown in the figure to block the gear (2), tighten the bolt (3) at the prescribed torque and remove the retainer 88013152; fit the coolant pump and alternator drive sheave, tightening the nut at the prescribed torque, remove the retainer 88013347 and refit the flywheel guard.
- Refit the arm and bar without tightening bolts (1 and 2) and bolts (3), fit the wheel and lower the car, then tighten the bolts (1 and 2) and the bolts (3) at the specified torque loading.
- Position the retainer 88013151 as shown in fig. 01 2/42 and refit the camshaft drive gears; then tighten the securing bolts at the specified torque and remove the retainer 88013151.

Refit the timing belt and carry out the timing operation as described at 01 2 6800.

Refit all the other parts removed in the reverse order to the removal.

SPECIAL TOOLS REQUIRED

- 88913042 Timing control fixture
- 88013151/152 - Timing gear retainers
- 88013347 - Retainer for locking crankshaft on flywheel side.
- 88091135/137 - Torque spqnners
- 88097827 Braket
- 88097120 - Stand

CYLINDER HEAD

§ 01 2 7700 Variant

REMOVING AND REFITTING THE CYLINDER HEAD

(including valve tappet clearance check and excluding setting)

Drive the car over the pit, fit the covers 8808351, drain off the coolant as at 01 2 4650 and *proceed as follows:*

Removing

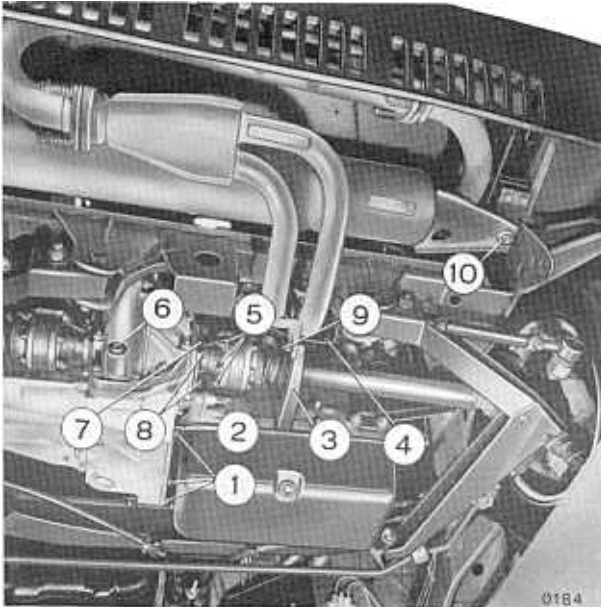

Fig. 01 2/47 - View of engine from below.

- Working in the pit, remove the securing nuts and bolts and take off the bracket (3) and heat guard (4).
- Remove the exhaust pipe from the manifold.
- Remove the spare wheel.

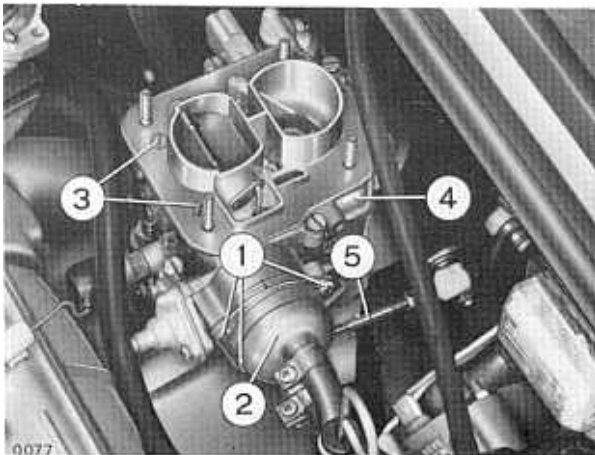

Fig. 01 2/48 - Carburettor seen from the automatic choke side.

- Remove the ignition distributor low voltage input cable and the spark plug cables and then distributor cap securing bolts and take off the cap along with the cables.
- Disconnect the cables from the coolant temperature gauge transmitter and from the thermostatic switch and the slow running cut-off cable and lay them aside.
- Remove the fluid to heater inlet coupling, remove the bolts (1) and take off the box (2), setting it on one side.
- Remove the nut securing the alternator upper clamping bracket and lift out the coolant pump and alternator drive belt.

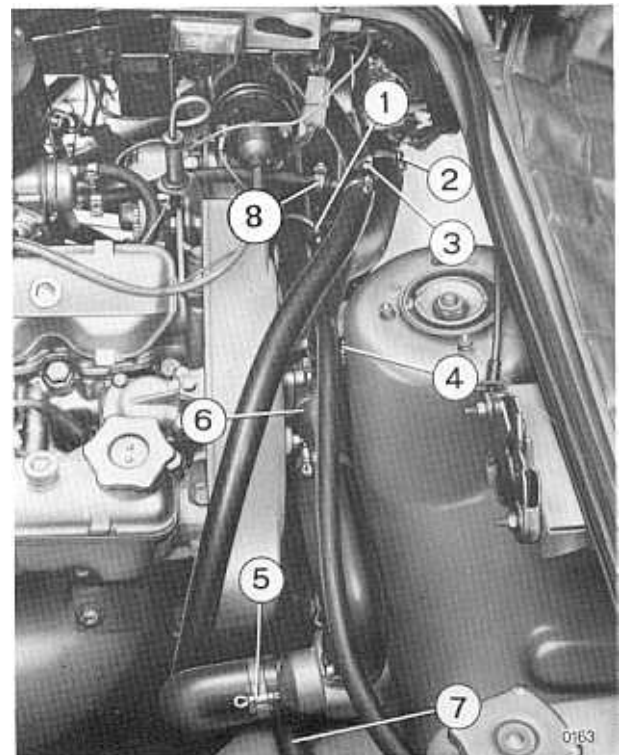

Fig. 01 2/49 - Coolant piping.

- Loosen the clamps (1, 2, 3, 4, 5 and 8), and remove the connector (6) together with couplings and thermostat.

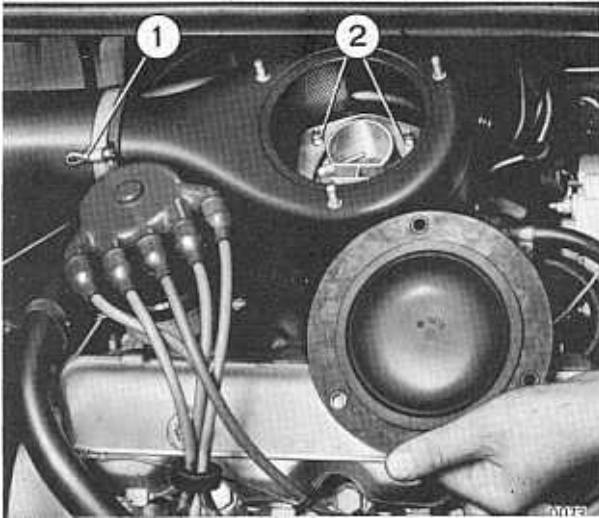

Fig. 01 2/50 - Air inlet.

- Remove the clamp (1) and take off the pipe.
- Remove the air inlet cover, unscrew the nuts (2), slip off the oil vapour breather tubes and remove the air inlet (3).
- Remove the fuel delivery and recovery hoses from the carburettor.
- Detach the accelerator idler lever and set it on one side.
- Slip off the servo low pressure pipe from the induction manifold.

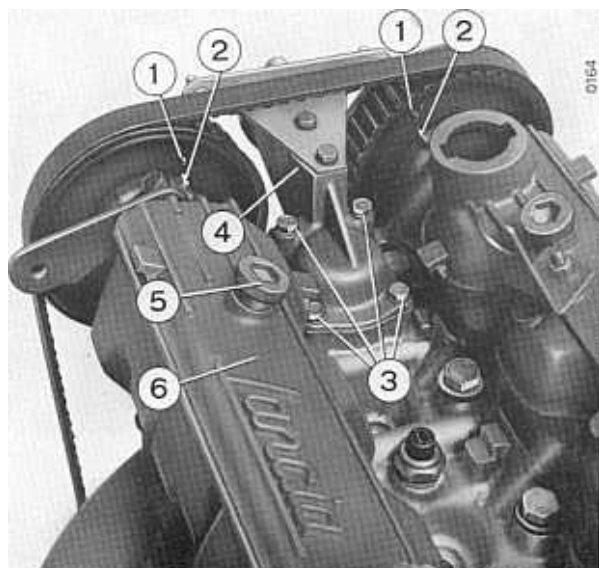

Fig. 01 2/51 - Upper part of engine.

- Remove the timing gear cover.
- Unscrew the bolts (3) and remove the pipe union (4).
- Turn the crankshaft in working direction (clockwise) until the holes (1) are aligned with the markings (2).
- Loosen the nut and bolt securing the timing belt stretcher, remove the belt from the gears and stretcher, laying it on one side.
- Remove the cylinder head mounting bolts and take off the head complete with manifolds (1).

Refitting

- Carefully clean the engine block mating surface.
- Apply the gasket to the cylinder head.
- Fit the cylinder head and secure it, tightening the bolts in the order and at the torque specified (2).
- Refit the timing belt and time the valve gear as described at 01 2 6950.
- Check the valve tappet clearance as described at 01 6500.
- Refit the other parts removed in reverse order to the removal.

SPECIAL TOOLS REQUIRED

- 88091135 Torque spanner

(1) For partial overhaul of the cylinder head see 01 4 2700.

(2) Torque tightening of the mounting bolts should be carried out in two stages and under no circumstances should the operation be carried out in one stage only.

(3) Should it be necessary to set the valve tappet clearance, see 01 2 6600.

ENGINE UNIT AND MOTIVE COMPONENTS

§ 01 2 8100

CHECKING THE CYLINDER COMPRESSIONS

Fit the covers 88083051 and *proceed as follows*:

- Start the engine and run it until the coolant temperature reaches 80-90°C (176-194°F).
- Stop the engine, remove the spark plugs and disconnect the high voltage lead from the ignition coil.
- Starting from cylinder No. 1, fit the pressure gauge recorder 88015453 to the spark plug port.
- Operate the starter motor to crank the engine, meantime keeping the accelerator pedal fully depressed.

This is to draw the maximum quantity of air inside the cylinder since the carburettor primary choke throttle valve is fully open.



Fig. 01 2/52 - Checking cylinder compressions.

At the same time, make sure that no air leaks are present between the pressure gauge connector and the spark plug port.

- Repeat this procedure on the other cylinders and make sure to reset the scribe each time as well as resetting the graph chart.
- Compare the graph readings, bearing in mind

that the values recorded in the various cylinders should coincide with those stated.

N.B. – The widest gap between maximum and minimum readings should not exceed 10% of the maximum value recorded.

Should the values differ from those specified, the reason may lie in bad sealing of valves or piston rings.

- Refit the spark plugs and reconnect the leads.

SPECIAL TOOLS REQUIRED

- 88015453 - Pressure gauge recorder.

§ 01 2 8200

REPLACING THE ENGINE MOUNTING BUFFER

Drive the car over the pit, fit the covers 88083051 and *proceed as follows*:

Removing

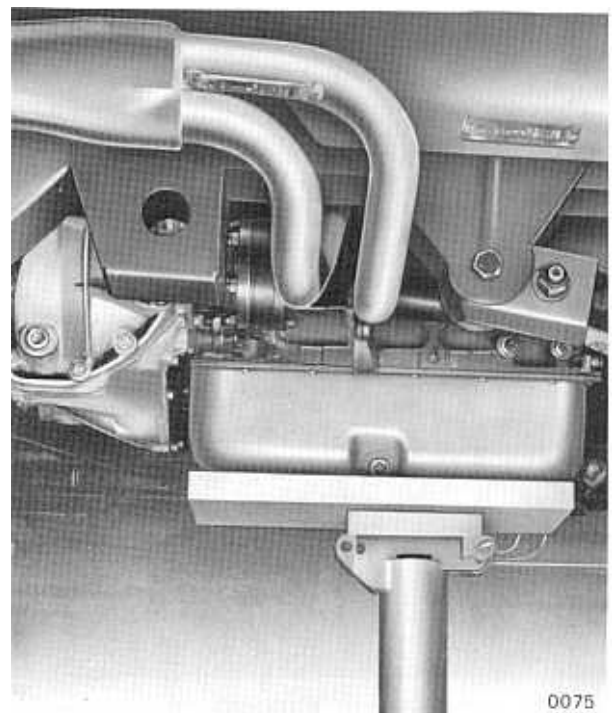

Fig. 01 2/53 - Positioning wooden block below sump.

01 ENGINE – CHAPTER 2

Engine unit and motive components

- Working below the car, position the hydraulic jack with bracket 88097827 below the sump, inserting a wooden block in between.

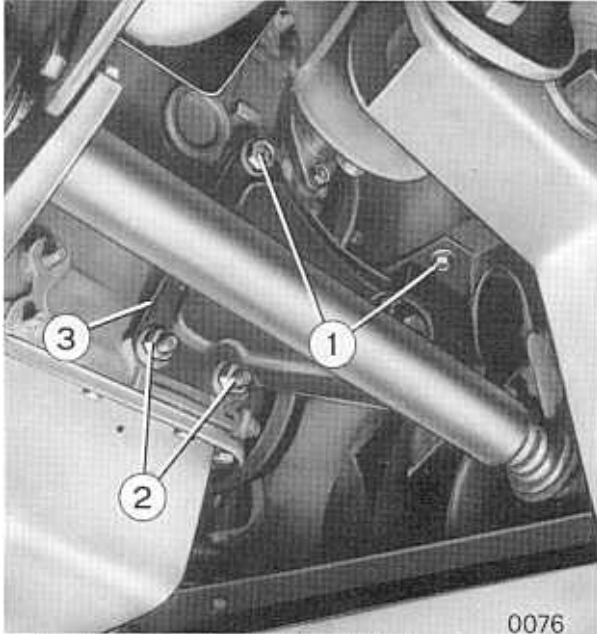

Fig. 01 2/54 - Front engine mounting

- Remove the bolts (1) and the nuts (2) and take off the engine mounting bracket.



Fig. 01 2/55 - Fixture 88032052 for removing and fitting mounting buffer.

- Using the fixture 88032052 at the press, remove the buffer from the bracket and fit the new one using the same fixture.

To refit, proceed in the reverse order to the removal.

SPECIAL TOOLS REQUIRED

- 88032052 - Fixture for removing mounting buffer
- 8809827 - Jack bracket

§ 01 2 8300

REPLACING THE CRANKSHAFT FRONT OIL SEAL

Drive the car over the pit, fit the covers 88083051, drain off the coolant as described at 01 2 4650 and *proceed as follows*:

Removing

- Remove the spare wheel from the engine compartment (also remove the heat shield SCORPION only).

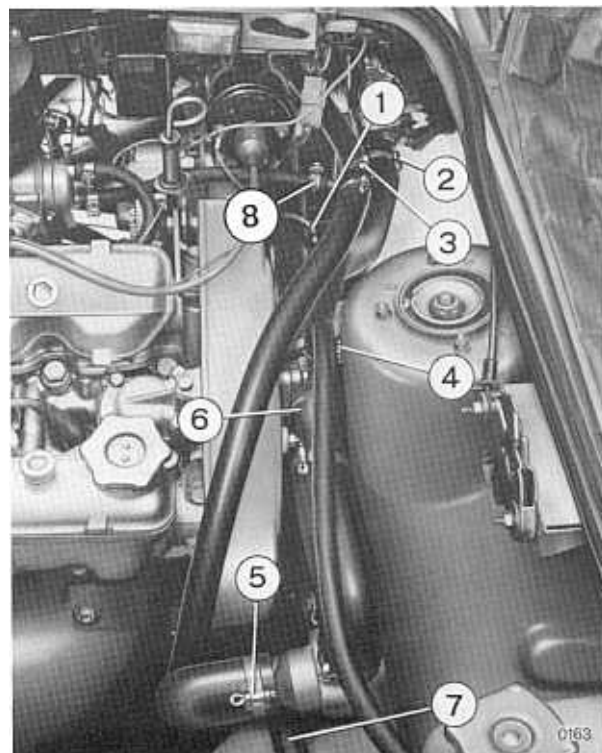

Fig. 01 2/56 - Coolant piping

- Loosen the clamps (1, 2, 3, 4, 5 and 8) and remove the connector (6) together with couplings and thermostat.
- Loosen the water pump and alternator drive belt stretcher and remove the belt.

Remove the mounting bolts and take off the timing belt guard cover.

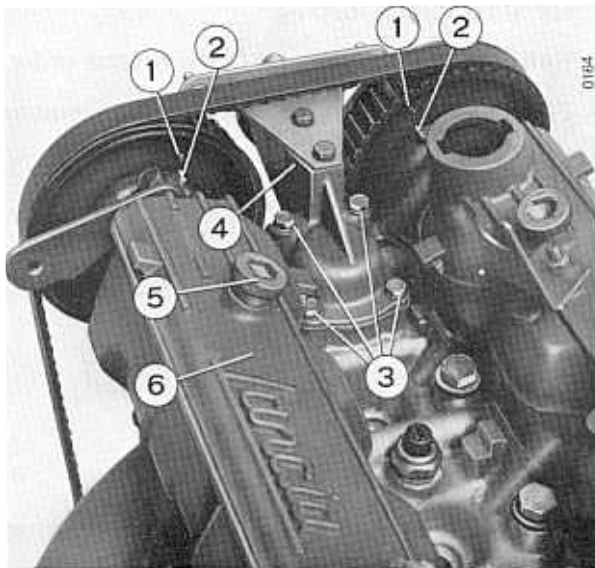

Fig. 01 2/57 - Engine from above.

Remove the bolts (3) followed by the pipe union (4).

Turn the crankshaft in its normal working direction (clockwise) until the holes (1) coincide with the marking (2).

Loosen the bolts securing the right rear wheel. Drain the oil, remove the mounting bolts and take off the sump.



Fig. 01 2/58 - Positioning the stand.

Raise the car at the rear using the hydraulic jack and bracket 88097827 and set it on the stand 88017120 as shown in the figure; remove the slackened wheel.

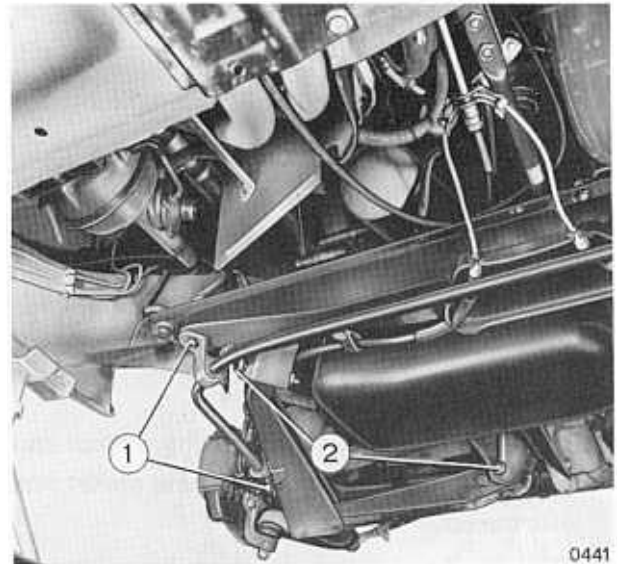

Fig. 01 2/59 - Right rear arm

- Remove the bolts (1 and 2) securing the stabilizer bar to the arm, remove the bolts (3) and take off the arm (4).

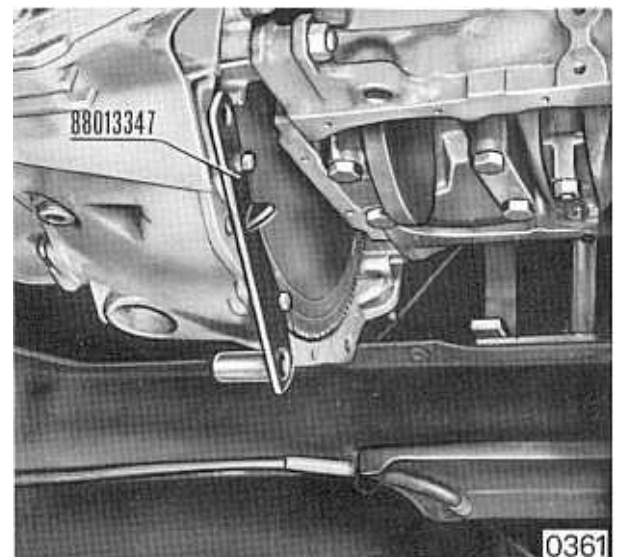

Fig. 01 2/60 - Positioning crankshaft locking tool 88013347.

- Detach the flywheel guard and fit crankshaft locking tool 88013347.
- Slacken the nut and bolt holding the timing belt stretcher and remove this from the

01 ENGINE – CHAPTER 2

Engine unit and motive components

crankshaft drive gears.

- Using the spanner 88091231, remove the nut securing the sheave to the crankshaft and take off the sheave.
- Remove the timing belt from the drive gear and then the drive gear from the crankshaft.
- Remove the mounting bolts and take off the crankshaft oil seal.

At the bench

- Remove the oil seal gasket from its seat on the cover using the appropriate tool.

Refitting

- Carefully clean the cover mating surface and the oil seal seat, then fit the new gasket and refit the cover.

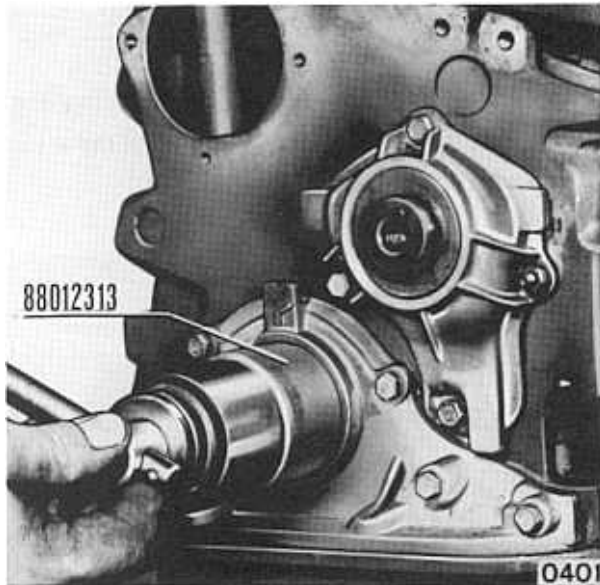

Fig. 01 2/61 - Installer 88012313 for oil seal fitting

Fit the new oil seal using installer 88012313. Refit the drive gear and the timing belt on the drive gear.

Fit the sheave and tighten the nut to the specified torque using spanner 88091231.

Remove the flywheel locking tool 88013347 and refit the guard.

Refit the timing belt and carry out the timing control as described at 01 2 6800.

Refit the pipe union (4) (see fig. 01 2/57),

followed by the timing belt guard cover.

- Refit the alternator and coolant pump drive belt and tighten the belt.
- Fit a new gasket and then refit the sump.
- Refit the arm and stabilizer bar without tightening up the bolts, fit the wheel and lower the car; then tighten the bolts to the specified torque loading.
- Refit the remaining parts in the reverse order.
- Fill up with coolant and deaerate the circuit as described at 01 2 4650.

SPECIAL TOOLS REQUIRED

- 88097120 - Stand
- 88013347 - Crankshaft locking tool
- 88012313 - Installer for fitting oil seal

§ 01 2 8310**REPLACING THE ANCILLARY UNITS DRIVE SHAFT OIL SEAL**

Drive the car over the pit, fit the covers 88083051 and *proceed as follows*:

Removing

- Remove the couplings, the coolant drive belt, the timing belt guard and the sheave as described at 01 2 8300 and the timing belt as described at 01 2 6800.

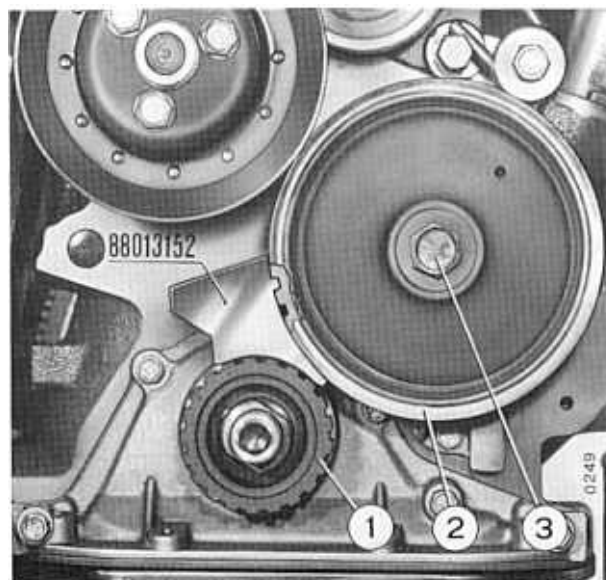

Fig. 01 2/62 - Ancillary units drive gear locking tool 88013152.

- Position tool 88013152 between drive gear (1) and gear (2), remove bolt (3), remove tool 88013152 and take off the gear (2).
- Remove the ancillary units shaft seal cover.
- Extract the oil seal gasket from its seat on the cover using the appropriate tool.

At the bench

- Extract the oil seal gasket from its seat on the cover using the appropriate tool.

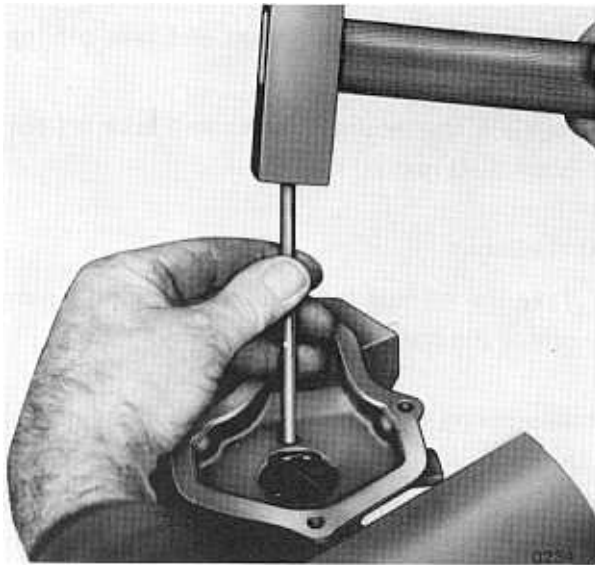

Fig. 01 2/63 - Removing the oil seal gasket from the ancillary units shaft cover.

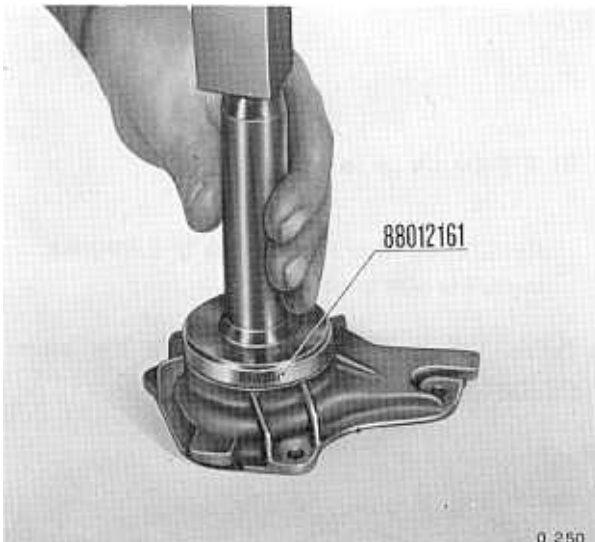

Fig. 01 2/64 - Installing oil seal gasket using tool 88012161.

- Clean the oil seal seat and fit the new gasket using installer 88012161.

Refitting

- Fit the new cover gasket and refit the cover.
- Refit the ancillary units drive shaft gear and sheave as described at 01 2 7500.
- Refit the timing belt and time the valve gear as described at 01 2 6800.
- Refit the remaining parts in the reverse order.

SPECIAL TOOLS REQUIRED

- 88013151 - Ancillary units drive gear locking tool
- 88012161 - Oil seal gasket installer

§ 01 2 8400

REMOVING AND REFITTING THE ENGINE OIL SUMP

Drive the car over the pit and *proceed as follows*:

Removing

Working under the car:

- Remove the plug and drain the engine oil into a clean container; then put the plug back in.
- Remove the mounting bolts and take off the flywheel guard.
- Remove the bolts securing the sump to the crankcase and take it off.

Refitting

- Replace the gasket and refit the oil sump
- Refit the flywheel guard.
- Fill up with engine oil.

01 ENGINE – CHAPTER 2

Engine unit and motive components

§ 01 2 8600

REMOVING AND REFITTING THE FLYWHEEL
(excluding removing and refitting gearbox and clutch)

After removing the gearbox-differential as described at 03 2 2500 and the clutch as described at 02 2 100, *proceed as follows*:

Removing

Fig. 01 2/65 - Positioning flywheel locking tool 88013347.

- Position tool 88013347 so that flywheel marking (1) is aligned with the tool's stop tooth. This flywheel position corresponds to the T.D.C. of pistons one and four.

Refitting

- Refit the flywheel in the position it held at removal and tighten the bolts at the specified torque loading.

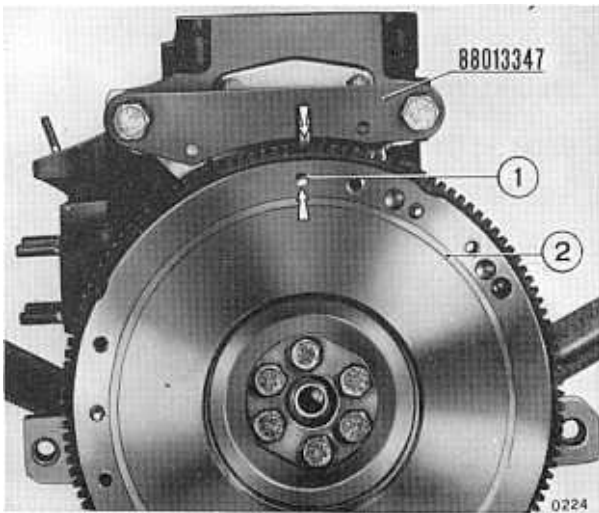
Complete the operation by refitting the clutch as described at 02 2 1000 and the gearbox-differential as described at 03 2 500

(1) To check the flywheel see 01 2 2300.

SPECIAL TOOLS REQUIRED

- 88013347 - Flywheel lock tool.

§ 01 2 8700

FITTING A NEW CRANKSHAFT REAR OIL SEAL

Remove the gearbox-differential assembly as described at 03 2 2500, the clutch as at 02 3 1000 and the flywheel as at 01 2 8600, and then *proceed as follows*:

- Remove the plug and drain the engine oil into a clean container and then put the plug back in.
- Remove the mounting bolts and take off the oil sump.
- Remove the mounting bolts and take off the crankshaft rear oil seal cover.

At the bench

- Take the oil seal from the cover and fit a new one at the press.

Reassembling

- Refit the rear oil seal cover to the engine block after fitting a new gasket.

Complete the operation by refitting the flywheel as described at 01 2 8600, the clutch as at 02 2 1000 and the gearbox-differential as at 02 3 2500.

§ 01 2 8800 *variant***REMOVING AND REFITTING THE ENGINE**
(complete with gearbox)

Drive the car over the pit, fit the cover 88083051, and *proceed as follows*:

Removing

From above the car:

- Remove the battery leads.

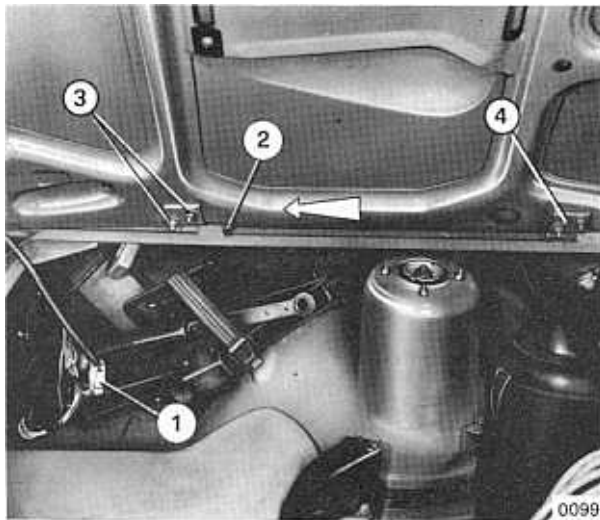

Fig. 01 2/66 Removing the bonnet.

- Remove the spare wheel, disconnect the bushing (1), unfasten the nut (2) and pull off the bonnet in the direction shown by the arrow.
- Drain the coolant as described at 01 2 4650.
- Remove the air cleaner assembly as described at 01 2 1700.

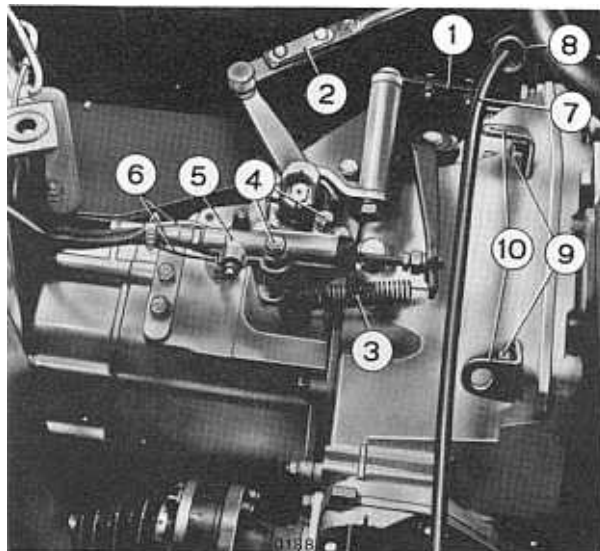

Fig. 01 2/67 - Gearbox control rods.

- Remove the gear selector and engagement rods (1 and 2).
- Remove the spring (3), unfasten the bolts (4) and take off the clutch servo cylinder (5).
- Detach the cables (6) from the reverse running lights switch.

- Detach the speedometer cable (7) from the differential and take it off the plate (8).

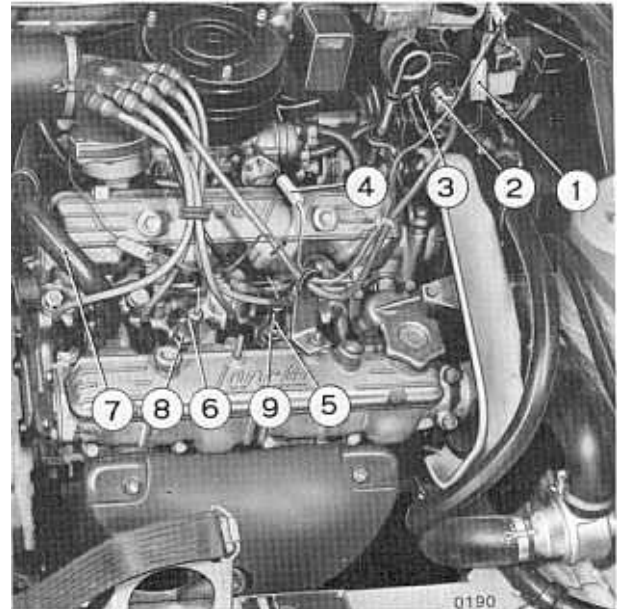

Fig. 01 2/68 - Sundry electrical connections.

- Detach the connection (1), detach the high and low voltage cables (2) and (3) from the coil, then remove the securing nuts and take off the coil.
- Remove the slow-running cut-off cable (4) and remove the cables (5) and (6) from the respective transmitters.

Remove the bracket complete with sheath and accelerator control rod from the carburettor and then detach the control rod.

- Take the fuel pipes from the carburettor.
- Remove the passenger compartment heater pipe.

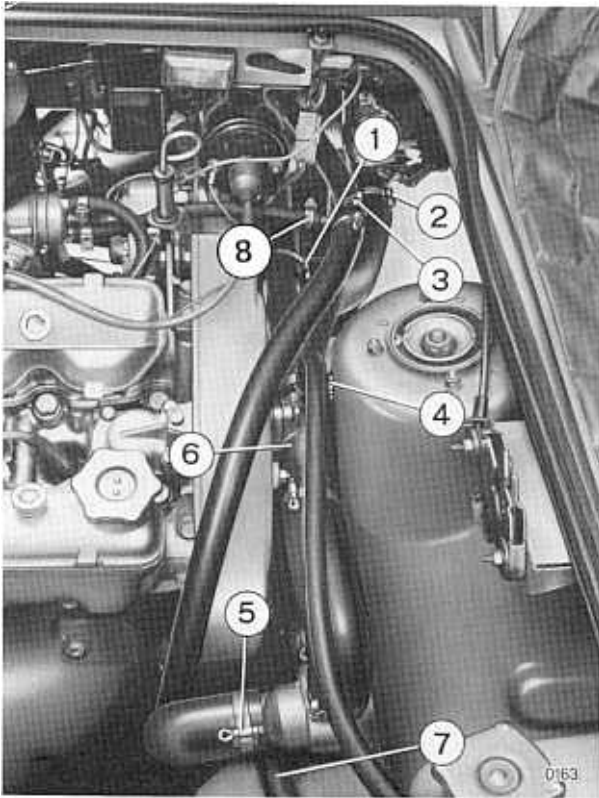

Fig. 01 2/69 - Coolant piping.

- Slacken the clamps (1, 2, 3, 4, 5 and 8), remove the mounting bolts and remove the coupling (6) complete with piping, and the thermostat.
- Remove the pump connector (7).
- Remove the heat guard from the exhaust manifold.

Working below the car:

- Remove the coolant recovery reservoir and refit the drain plugs.
- Remove the alternator as described at 14 2 7200 and then remove the oil filter base as described at 01 2 6000.
- Remove the brake servo hose from the induction manifold.
- Remove the cables from the starter motor and the rear clamping bracket.

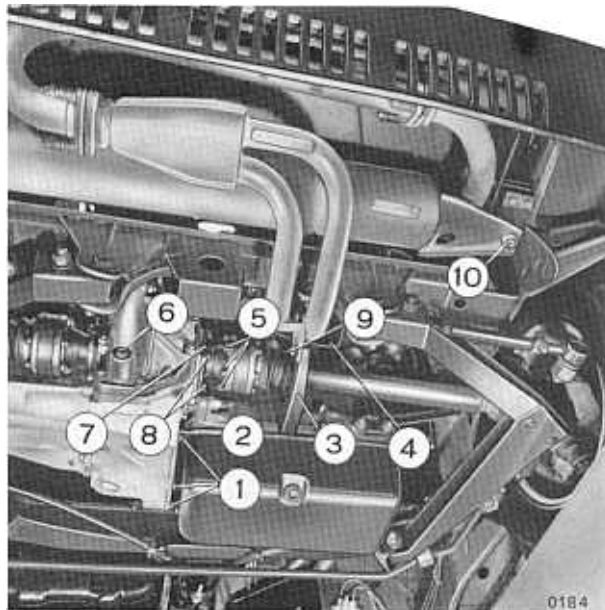

Fig. 01 2/70 - View of the engine from below.

- Remove the bolts (1) and take off the guard (2).
- Remove the bracket (3) between the exhaust pipe and the engine, remove the guard (4) and then remove the exhaust pipe from the manifold.
- Unfasten the bolts (5) and remove the transmission from the gearbox.
- Fit the engine-gearbox unit lifting arms 88017363.

Above the car:

- Place the hoist above the car, secure the engine to lifting hook 88017362 and cable 88097251 set as shown in fig. 01 2/ and take up the slack.

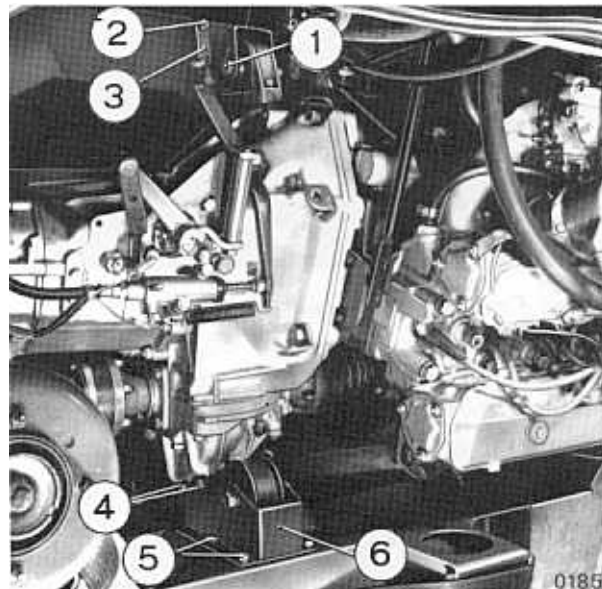

Fig. 01 2/71 - Gearbox mountings

- Unfasten and remove bolt (1), remove bolts (2) and take off the mounting (3).
- Unfasten and remove bolts (4), remove bolts (5) and take off the mounting (6).

Below the car:

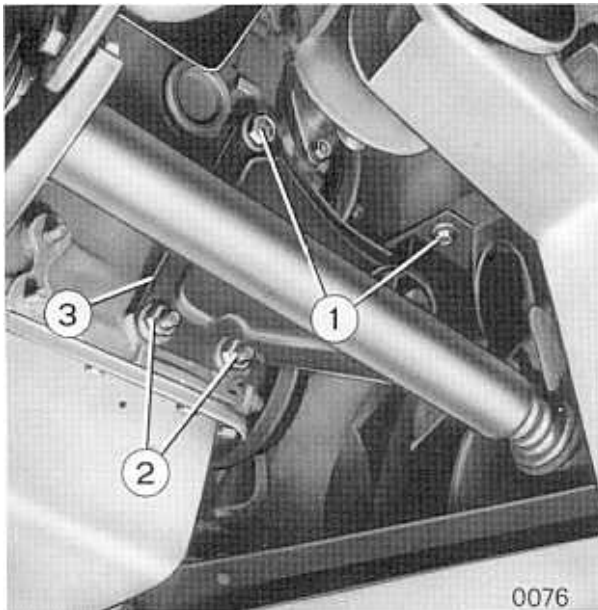

Fig. 01 2/72 - Engine mounting.

- Remove the bolts (1) and nuts (2) and then take off the mounting (3).

Above the car:

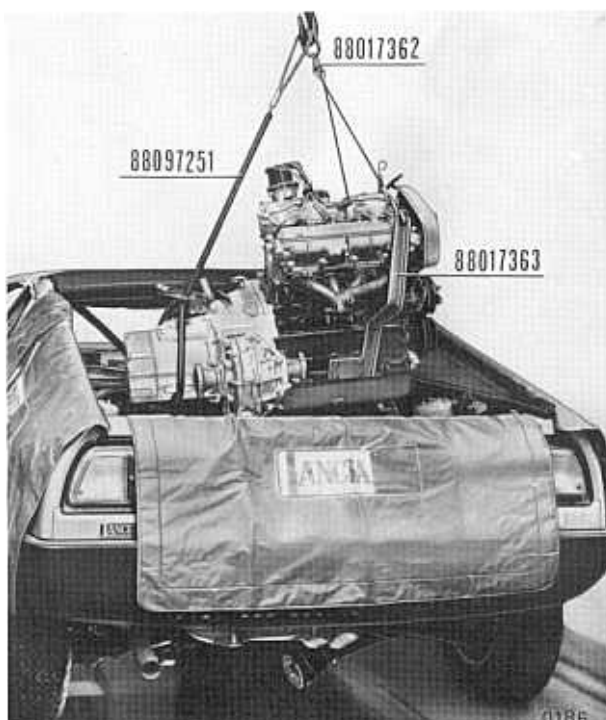

Fig. 01 2/73 - Lifting engine-gearbox from the car.

- Lift the engine-gearbox unit out of the car and place it on bed 88017364.

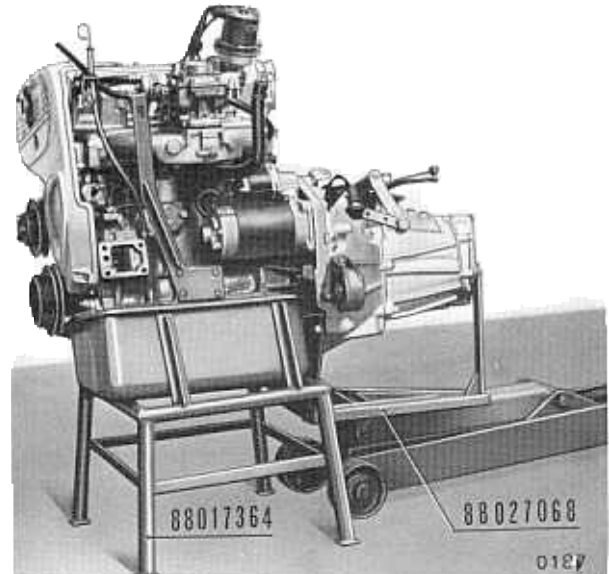

Fig. 01 2/74 - Removing gearbox-differential from the engine on the bed.

- Fit cradle 88027068A to the gearbox and then insert the trolley jack so that the cradle can be slightly raised.
- Remove the starter motor, remove the bolts securing the gearbox to the engine and then remove the gearbox from the engine.

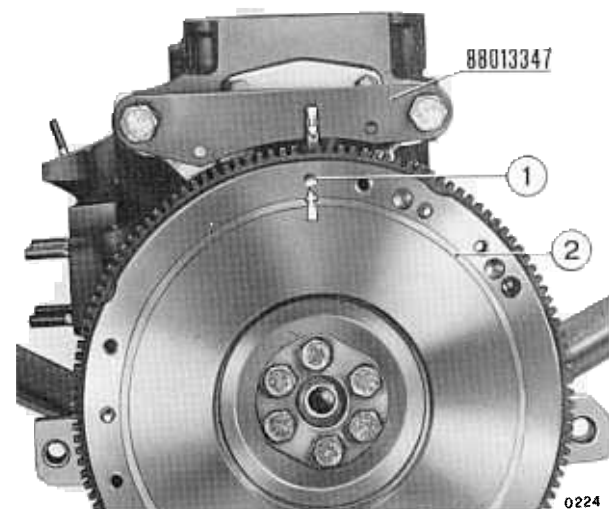

Fig. 01 2/75 - Locking the flywheel with fixture 88013347.

- Lock the flywheel with fixture 88013347, remove the securing bolts and take off the complete clutch assembly.

01 ENGINE – CHAPTER 2Engine unit and motive components

Refitting

- Refit the clutch assembly using the tool 88023030 for locating the disc.
- Refit the gearbox to the engine, tightening the mounting bolts to the specified torque loading.
- Working in reverse order to the removal, refit the engine-gearbox assembly in the engine compartment, taking care to tighten bolts securing the constant velocity joints to the flanges at the specified torque loading.
- Adjust the gear selector and engagement levers, tighten the mounting bolts at the specified torque loading, and then test gear engagement.
- Refill and deaerate the cooling system as

described at 01 2 4650.

- When reassembly is completed, start the engine and check for leaks; then adjust the slow-running mechanism as described at 01 2 2300.

SPECIAL TOOLS REQUIRED

- 88017363 - Engine-gearbox unit lifting arms
- 88017362 - Engine lifting hook.
- 88097251 - Cable
- 88027058 - Gearbox support
- 88017364 - Bed for detached engine-gearbox unit.
- 88013347 - Crankshaft locking fixture
- 88023030 - Clutch disc locating tool.

CHAPTER 3

§ 01 3 0010

ENGINE OVERHAUL ACCESSORY OPERATIONS

(Removing and refitting electric parts – Fitting and removing the covers – washing the engine).

Proceed as follows:

Remove the distributor and fit covers to protect the carburettor and the distributor seating.

- Remove the engine from bed 88017364, carefully wash the outside and dry with air pressure; then remove the covers.
- When the wash is completed or after repair jobs have been carried out, refit the ignition distributor and remove the covers.

TOOLS REQUIRED

- 88017364 Bed

§ 01 3 0100

FITTING THE ENGINE TO THE OVERHAULING STAND AND REMOVING IT (Including draining engine oil and refilling)

Proceed as follows:

Fitting

- Fit the supports 88017361 to the engine block, fit lifting hooks 88017362 to the intake and exhaust manifolds and raise the engine by means of a hoist; then drain the oil from the sump.
- Fit plates 88017369 to the stand and then clamp the engine to them.

Removing

- Remove the engine from the stand by means of the hoist and hooks 88017362.

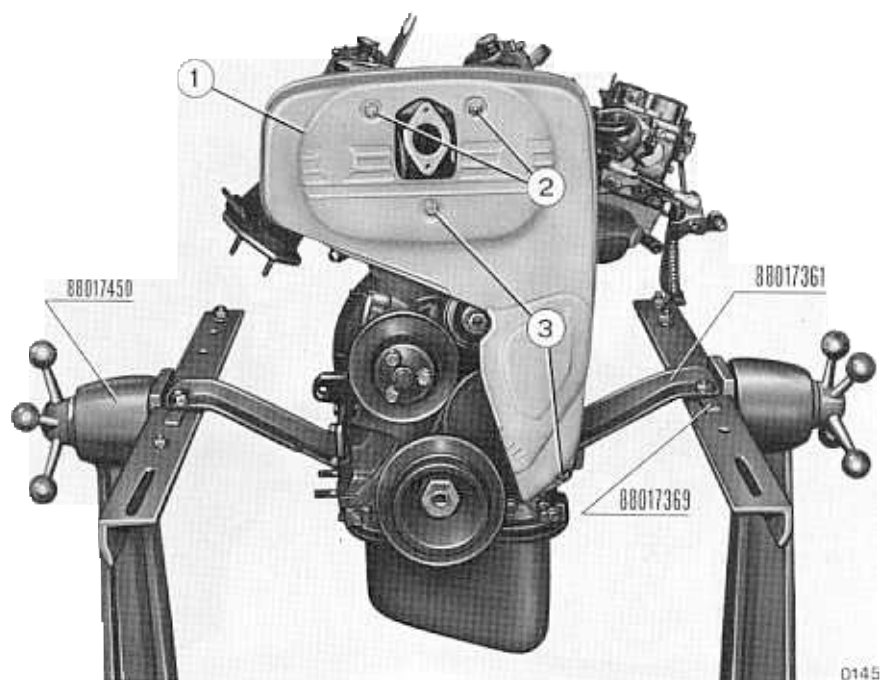

Fig. 01 3/1 Engine fitted to overhauling stand

- Remove the support 88017361 and plates 88017369.
- Fill up with the specified quantity of engine oil and place the engine on the bed 88017364.

TOOLS REQUIRED

- 88017361 - Supports
- 88017362 - Engine lifting hooks
- 88017369 - Plates
- 88017450 - Stand
- 88017364 - Bed

§ 01 3 0250

REMOVING AND REFITTING THE TIMING BELT, TIMING THE VALVE GEAR AND CHECKING THE VALVE TAPPET CLEARANCE WITH ENGINE AT THE BENCH

Carry out the operations described at 01 3 0010 and then *proceed as follows*:

Removing

- Remove the nuts (2) and bolts (3) (see figure 01 3/1) to remove the timing gear cover (1) and then remove the spark plugs.

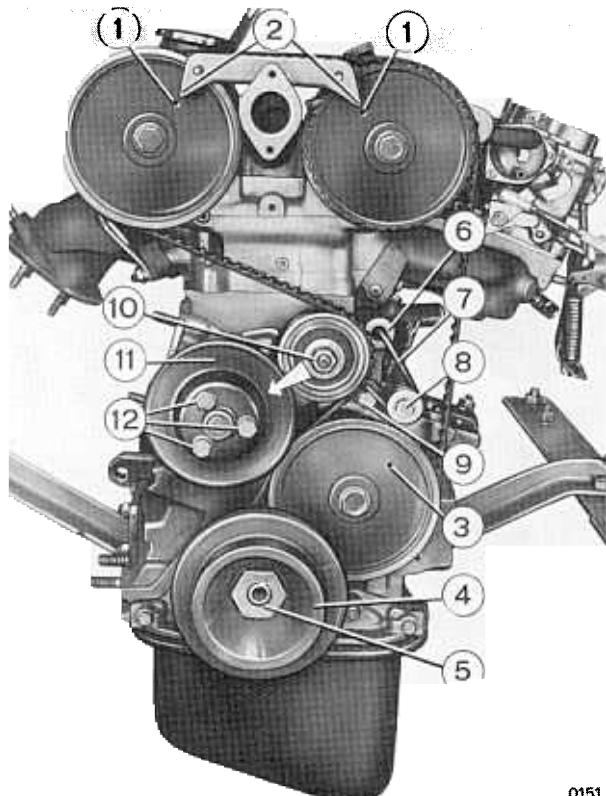

0151

Fig. 01 3/2 - Engine from the front

- Fit the handles 88013344 on the flywheel and turn the crankshaft in its normal working direction until the bores (1) are in line with the reference marks (2).

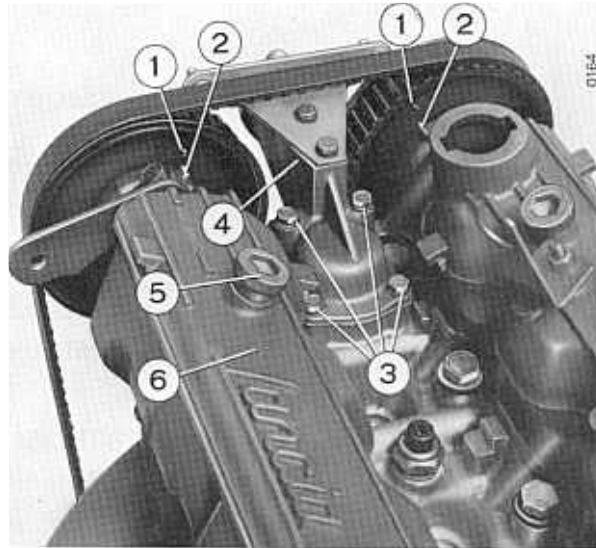
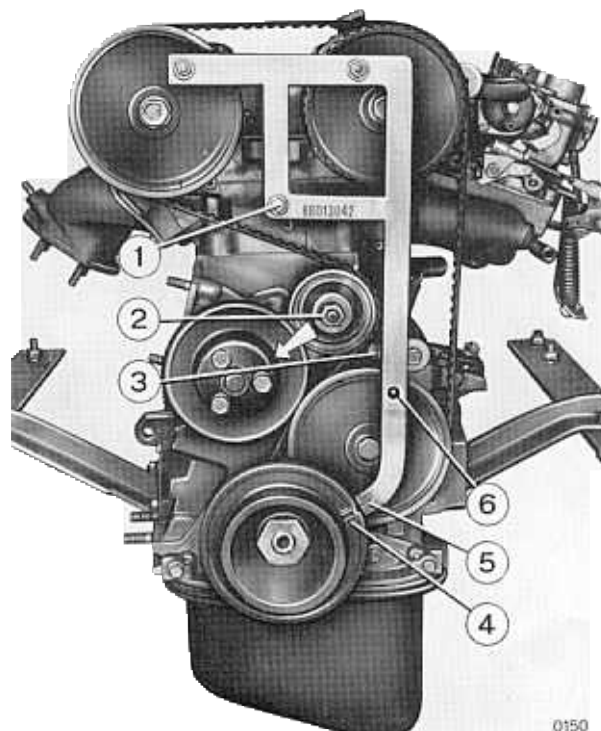

Fig. 01 3/3 - Engine from the top

- Remove the knurled nuts (5) and the covers (6) together with the respective gaskets, remove the bolts (3) and take off the coupling (4) together with the reference marks.



0150

Fig. 01 3/4 - Positioning of fixture 88013042

- Fit the fixture 88013042 so that the reference bores (1) of fig. 01 3/2 are in line with the dowels, then fix the fixture to the cylinder head by means of bolt (1).
- Release the belt stretcher nut (2) and bolt (3), lever the stretcher as shown by the arrow and at the same time tighten the bolt (3), so releasing tension on the belt; then slip off the valve gear drive belt.

Refitting

- Make sure that the reference mark (4) on the crankshaft sheave is in line with the mark (5) on the fixture and that the dowel (6) coincides with the bore on the ancillary units drive gear (ref. 3 of fig. 01 3/2); the fact that these references coincide means that pistons one and four are at T.D.C. and that the cam on the ancillary units drive shaft is in such a position that it does not interfere with the crankshaft during its rotation.
- Fit the new belt, release the bolt (3) so as to tighten the belt, then tighten bolt (3) and nut (2) (the latter at the specified torque loading), remove the fixture 88013042 and turn the crankshaft a few times, partially release the belt stretcher so as to settle the belt and then lock it.
- Refit the coupling (4) (see fig. 01 3/3) with the timing reference marks set.

Checking the valve tappet clearance

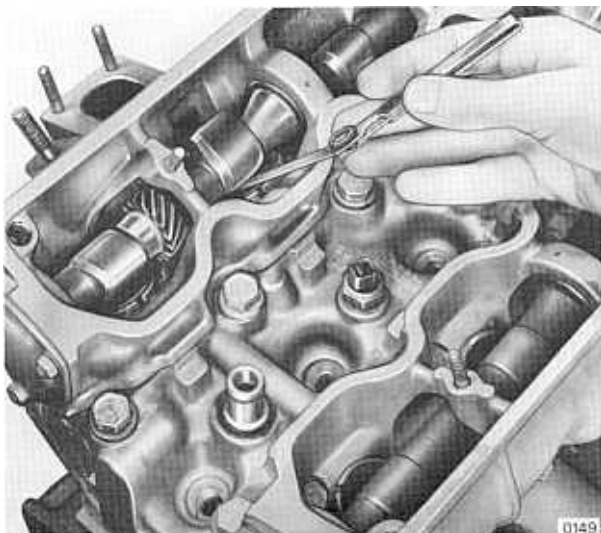

Fig. 01 3/5 - Checking valve tappet clearance

- Crank the engine so that cylinders 1, 3, 4, 2 are fired in that order and, using the feeler gauge 88095770, gradually check the clearance of the intake and exhaust valves of each cylinder. The readings should be noted. Example:

The 0.40 mm blade goes but the 0.45 mm blade does not; clearance will therefore be greater than 0.40 mm and less than 0.45 mm.. For more precise measurement, add to the blade that goes (0.40 mm) a feeler of 0.03 mm.; if the combination goes the clearance value lies between 0.40 and 0.43 mm, if it does not clearance lies between 0.43 mm and 0.45 mm. In the former case 0.42 mm and in the latter 0.44 mm will be considered as the effective values; clearly if clearance deviates from the specification, reset the tappets as described at 01 3 0420.

- Refit the remaining parts removed in the reverse order, taking care to replace any worn gaskets; then remove the handles 88013344. Finish off by performing the operations described at 01 3 0100 and 01 3 0010.

TOOLS REQUIRED

- 88013344 - Handles
- 88013042 - Timing gear retaining fixture
- 88095770 - Feeler gauge

§ 01 3 0300

REMOVING AND REFITTING THE CYLINDER HEAD FROM THE ENGINE AT THE BENCH

Note: When removing and refitting the cylinder head, do not turn the crankshaft to prevent valves being damaged; if necessary, the crankshaft can be turned when the cylinder head is detached, but in this case care must be taken to position piston No. 1 at its T.D.C. before refitting the head.

After carrying out the operations described at 01 3 0010, and 01 3 0250, *proceed as follows:*

Removing

- Remove the tool 88013042
- Remove the alternator drive belt stretcher and the oil gauge rod guide tube
- Remove EGR valve (SCORPION only).
- Remove the cylinder head mounting bolts and take off the head with gasket (To check for flatness or for the partial overhauling of the cylinder head, see respectively 01 4 2650 and 01 4 2700).

Refitting

- Carefully clean the engine block top surface.

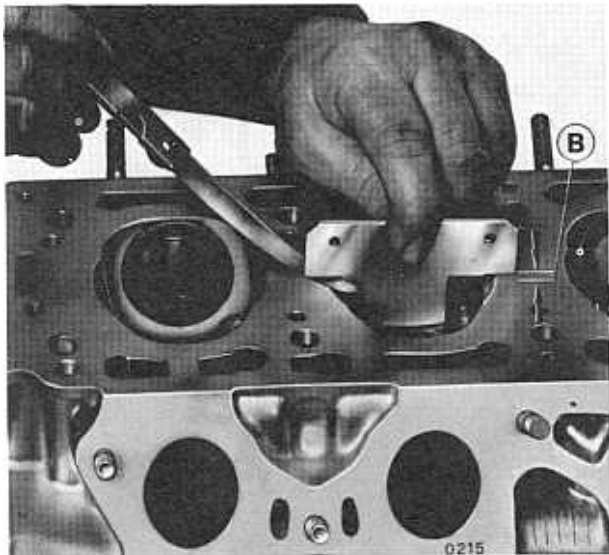

Fig. 01 3/6 - Checking combustion chamber depth using gauge 88015038.

- Check the depth of the cylinder head combustion chamber with gauge 88015038 and feeler gauge 88095770. The clearance (B) between the gauge and the cylinder head surface, should fall within specified values.
- Fit the new gasket and the dowels to the engine block.

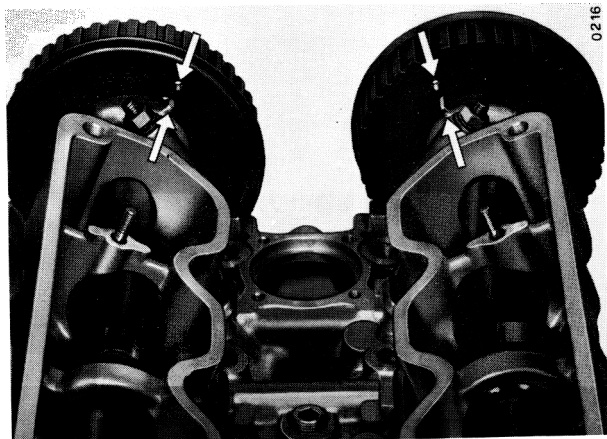

Fig. 01 3/7 - Setting camshaft drive gears before refitting the head.

- Set the camshaft drive gears so that the timing holes are in line with the markings on the front bearings.
- Fit the cylinder head and tighten the mounting bolts in the sequence and at the torque specified and then refit the alternator drive belt stretcher and the oil gauge rod guide tube.
- Fit the timing drive gear retainer 88013042.

Finish off by carrying out the operations described at 01 3 0250, 01 3 0100 and 01 3 0010

TOOLS REQUIRED

- 88015038 - Gauge
- 88095770 - Feeler gauge
- 88013042 - Timing gear retainer

§ 01 3 0420

SETTING THE VALVE TAPPET CLEARANCE WITH THE ENGINE AT THE BENCH*Proceed as follows:*

- Turn the crankshaft until the lobe controlling the tappet in question is turned upwards and is perpendicular to the shim; then position one of the tappet slots as shown in the figure below.

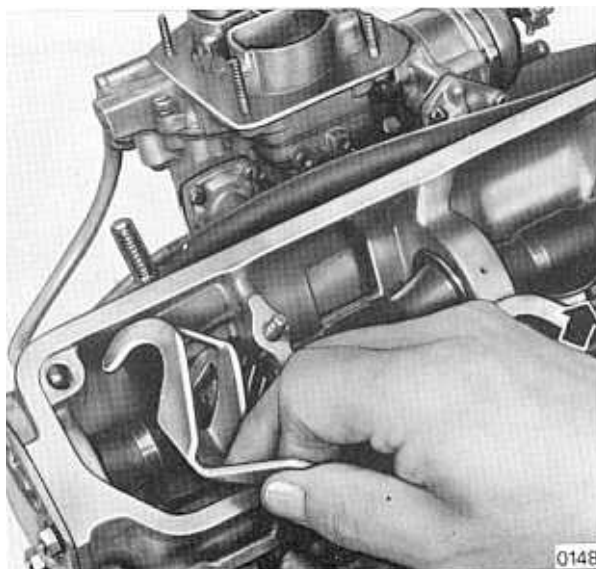

Fig. 01 3/8 - Using shim extraction tool 88013036.

- Turn the crankshaft further until the valve controlled by the tappet to be set is completely open, then apply tool 88013036 and continue to turn the crankshaft till the lobe leaves the tappet; tool 88013036 will now hold the tappet in the open valve position.

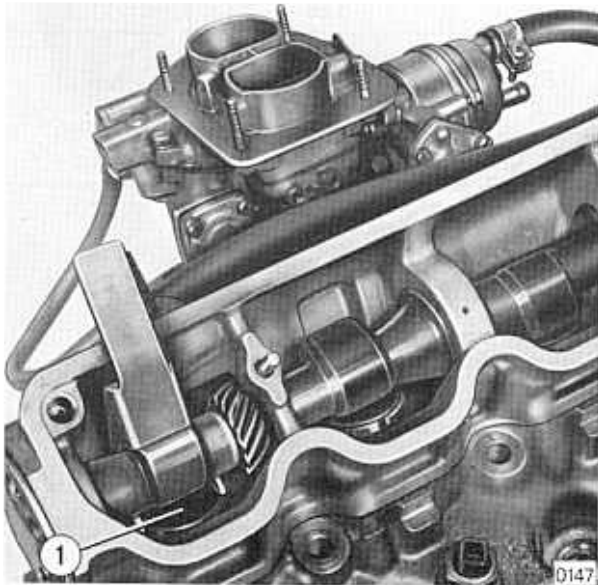

Fig. 01 3/9 - Locking tappets with shim extraction tool 88013036.

- Shift the shim (1) by means of air pressure on the tappet slot or using an appropriate tool, then extract it with pliers 88013038.



Fig. 01 3/11 - Kit 88013040 consisting of case 88013037, support 88019051 and dial gauge 88095122.

- Measure the thickness of the shim with the dial gauge and the surface plate supplied with the trolley 88013055 and kit 88013040.

To measure the thickness of the shim to be fitted, *proceed as follows*:

- Add the clearance of the tappet just checked (see 01 3 0250) to the thickness of the shim removed; then subtract the clearance specified for the valve. The difference is the thickness of the shim to be fitted (see table).

Note - The thickness value is stamped on the bottom surface of the shim; it is, however, good practice to check that this corresponds to the thickness of the shim removed by means of the dial gauge.



Fig. 01 3/10 - Trolley for Tappet Adjusting Shims.

Clearance gauged mm	Thickness of shim removed mm	Clearance gauged plus thickness of shim removed mm	Specified valve clearance mm	Calculation to determine thickness of new shim	Thickness of shim to be fitted mm
Intake valve 0,36	3,65	4,01	0,45	$\begin{array}{r} 4,01 - \\ 0,45 - \\ \hline 3,56 \end{array}$	3,55
Exhaust valve 0,49	4,20	4,69	0,60	$\begin{array}{r} 4,69 - \\ 0,60 - \\ \hline 4,09 \end{array}$	4,10

- Fit the new shim using pliers 88013038, turn the crankshaft until the camshaft lobe presses the tappet in question right down, then remove tool 88013036.
- Proceed in the same way when setting the remaining tappets.

TOOLS REQUIRED

- 88013036 - Tappet retaining tool
- 88013038 - Pliers
- 88013055 - Shim trolley

§ 01 3 0520

REMOVING AND REFITTING THE TIMING BELT STRETCHER, SPRING, CRANKSHAFT GEAR, CAMSHAFT GEARS, ANCILLARY UNITS DRIVE SHAFT GEAR AND COOLANT PUMP WITH THE ENGINE AT THE BENCH

Carry out the operations described at 01 3 0010, 01 3 0100 and 01 2 0250 and then *proceed as follows*:

Removing

- Remove the tool 88013042 by unfastening the bolt securing it to the head.

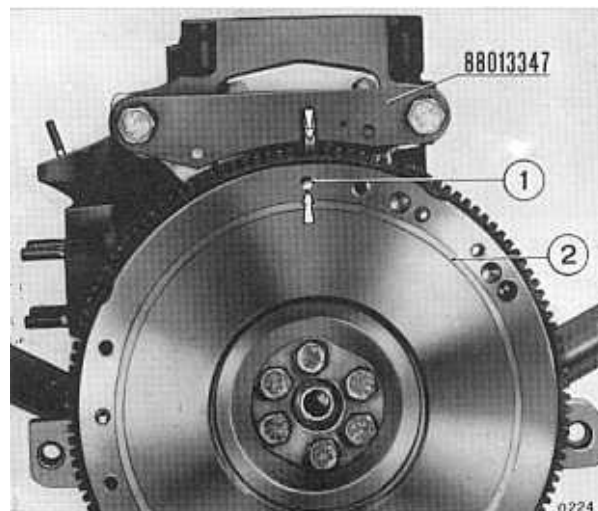

Fig. 01 3/12 - Fitting the Flywheel Locking Tool 88013147.

- Fit tool 88013347 in such a way that the reference marking (1) on the flywheel is in line with the tool stop tooth. This flywheel position corresponds with T.D.C. of pistons one and four.
- Using spanner 880911231, remove the nut securing the sheave to the crankshaft and then remove the sheave.

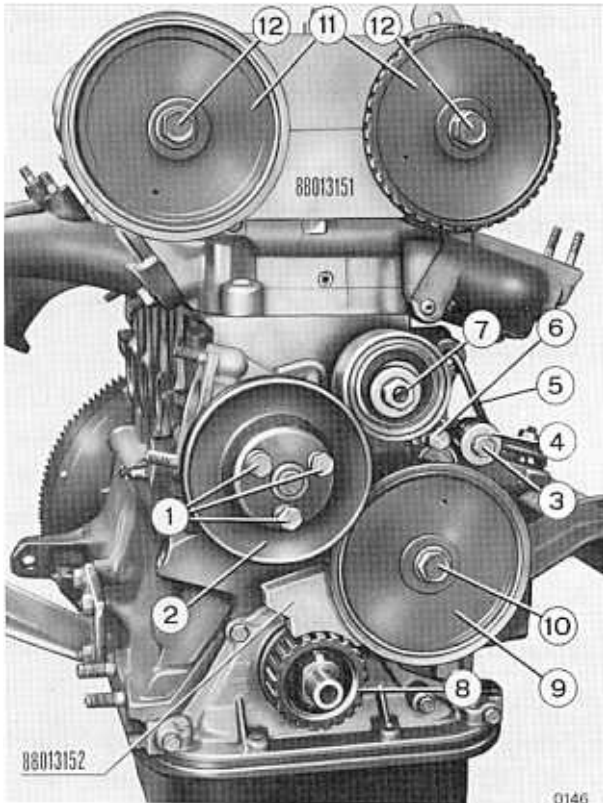

Fig. 01 3/13 - Tools 88013152 and 88013151 fitted to front part of engine to lock ancillary units drive gear and camshaft drive gears.

- Remove the bolts (1) and the sheave (2), then take off the respective mounting bolts and remove the coolant pump.
- Unfasten bolt (3) and remove the spacer, the thrust washers (4) and the spring (5).
- Unfasten the bolt (6) and nut (7) and remove the stretcher.
- To remove the ancillary units drive shaft gear or the camshaft drive gears, *proceed as follows*:
- Apply tool 88013152 between the crankshaft gear (8) and the ancillary units drive shaft gear (9), unscrew the bolt (10), and remove gear (9); then take off gear (8).
- Apply tool 88013151 between gears (11), tighten its bolt, unfasten the securing bolts (12), remove tool 88013151 and the gears (11).

Should it be necessary to replace the camshaft oil seals, remove the camshaft housings as

described at 01 2 7010.

Checking stretcher spring loading

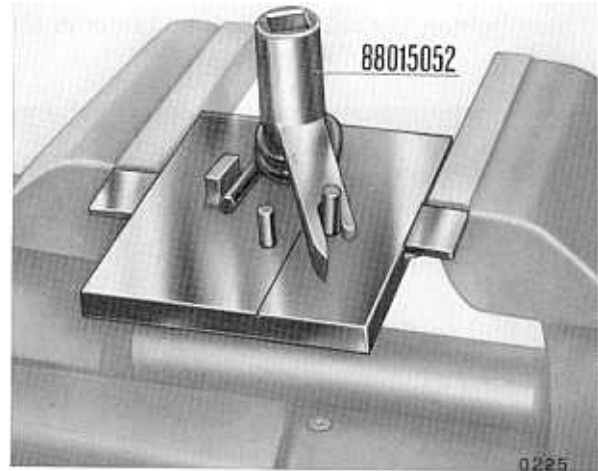

Fig. 01 3/14 - Timing belt stretcher spring fitted to tool 88015052.

- Fit the spring to tool 88015052.

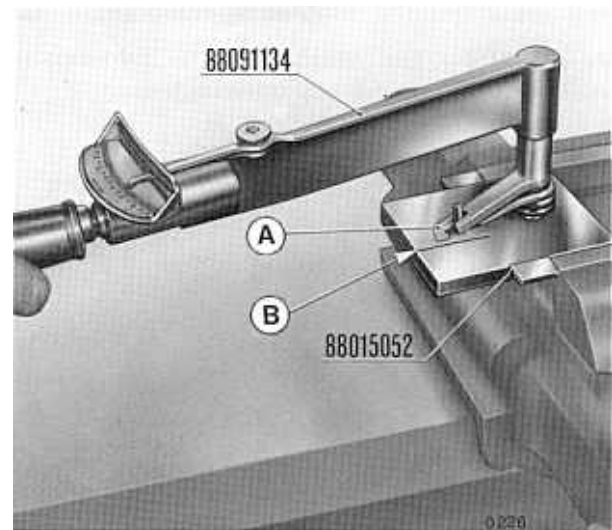

Fig. 01 3/15 - Testing stretcher spring loading.

- After setting it to the specified loading, apply the torque spanner 88091134 to the square drive of tool 88015052 and work on the spanner until the snap-lock is felt, making sure the snap takes place when pointer tip A is in line with tool reference marking (B) on the tool surface.

Should the pointer tip overshoot the tool reference mark when the snap-lock is applied, the belt stretcher spring must be scrapped.

Refitting

- Apply the tool 88013151 as shown in figure 01 3/13 and refit the camshaft drive gears; then tighten the locking bolts and remove the tool.

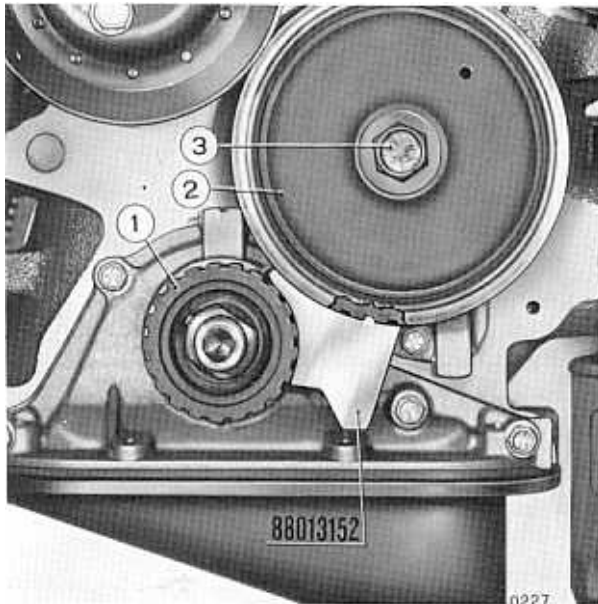

Fig. 01 3/16 - Tool 88013152 set for tightening of ancillary units drive shaft gear mounting bolts.

- Refit the gear (1) to the crankshaft and gear (2) to the ancillary units drive shaft, then apply tool 88013152 as shown in the figure to block the gear (2), tighten bolt (3) and remove the tool 88013152.
- Refit the sheave (4) on the crankshaft, tightening nut (5) at the specified torque loading and remove flywheel locking tool 88013347.
- Refit the stretcher support (6) and spring (7), tighten the spring clamping bolt (8) and leave bolt (9) and nut (10) loose; push the stretcher in the direction of the arrow and partially tighten the bolt (9) and nut (10).
- Refit the coolant pump, fitting a new gasket, then tighten bolts (12) and refit the sheave (11).
- Apply camshaft drive gear retaining fixture 88013042 and clamp it to the cylinder head.

Complete by carrying out the operations described at 01 3 0250, 01 3 0100 and 01 3 0010.

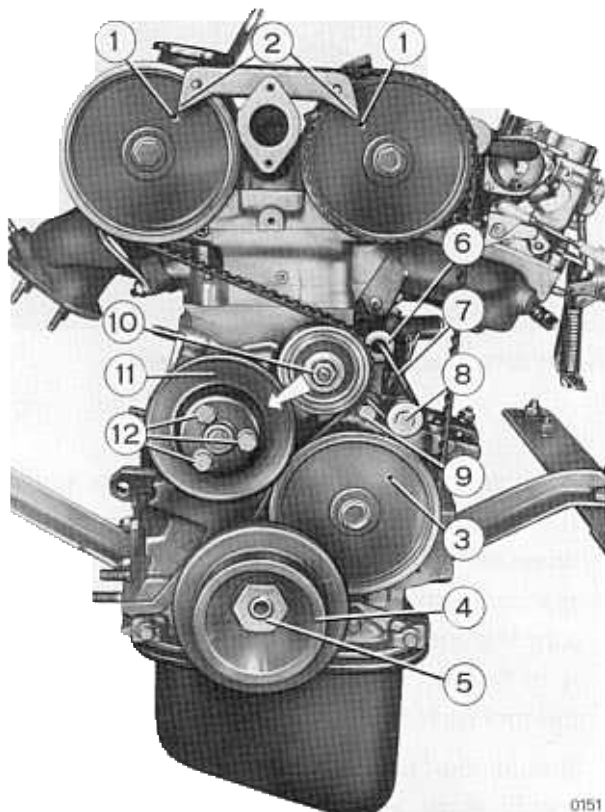

Fig. 01 3/17 - Engine from the front.

§ 01 3 0910

REMOVING AND REFITTING THE OIL SUMP, OIL PUMP, CONNECTING RODS AND PISTONS FROM THE ENGINE AT THE BENCH
(Including respective checking operations).

Carry out the operations described at 01 3 0010, 01 3 0100, 01 3 0250 and 01 3 0300, and *proceed as follows:*

Removing

- Set the engine on the stand with the oil sump facing upwards.
- Unscrew the mounting bolts and remove the sump with gasket.
- Unscrew the mounting bolts and remove the oil pump, unscrew the securing nuts and remove the conrod caps, then remove the pistons complete with conrods.

Measuring and checking operations

- Check visually that the pins and shells do not show signs of seizure or scoring; if any such defects are found on the pins, remove the crankshaft (see 01 3 1100) and regrind the pins; if the trouble is encountered on the shells and subsequent checks show that the pins are acceptable, simply replace the shells.

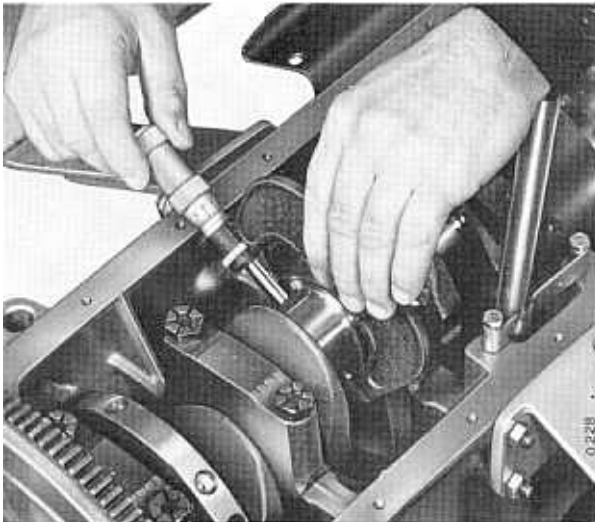

Fig. 01 3/18 - Measuring the crankpins.

- Using a centesimal dial gauge 88095467 or 88095466, check that the crankpin diameters are acceptable; if not, recondition the crankshaft as described above.
- Turn the engine by 180° on the stand.

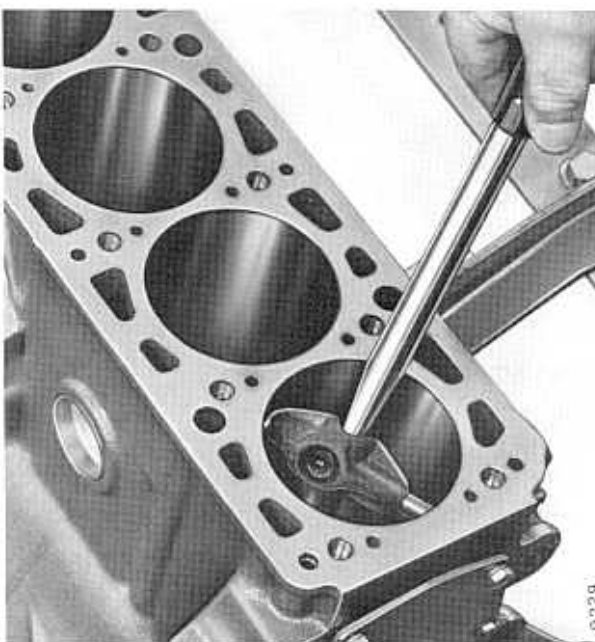

Fig. 01 3/19 - Gauging the cylinders.

- Clean the cylinders thoroughly and check them visually for wear, looking especially for signs of seizure or scoring; if such faults are found, remove the crankshaft (see 01 3 1100) and rebore the cylinders (see 01 3 2800).

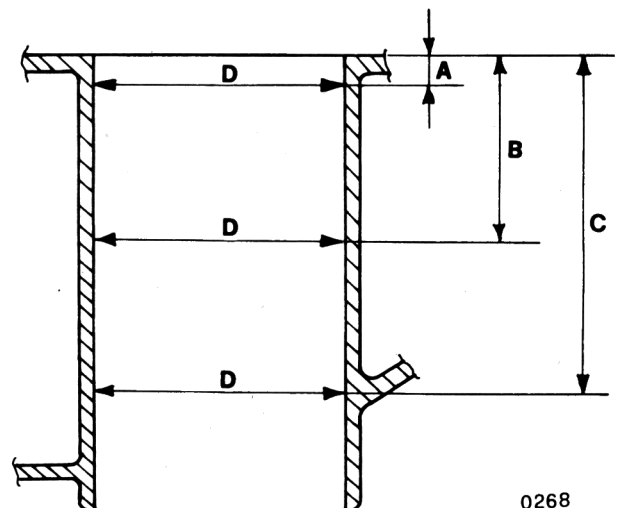
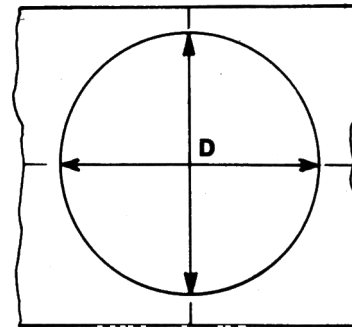

Fig. 01 3/20 - Cylinder gauging spots.

- If gauging shows excessive ovalization, remove the crankshaft (see 01 3 1100) and rebore the cylinders (see 01 3 2800).
- Check the pistons visually for signs of seizure or scoring, then use pliers 88012202 to remove the piston rings, taking care to observe their position so that they can be correctly refitted.
- Clean the pistons thoroughly.

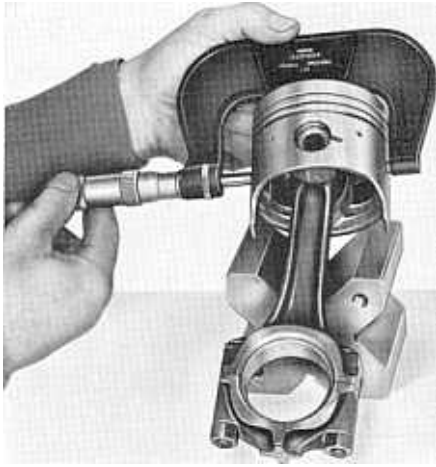

Fig. 01 3/21 - Gauging the pistons.

- Gauge the pistons with micrometer 88095468; if play is excessive, rebore the cylinders (see 01 3 2800) and fit oversize pistons. Using a suitable point, remove the gudgeon pin circlips and then remove the gudgeon pins and lift off the conrods by means of tool 88012209.
- Check that the gudgeon pin surfaces are perfectly smooth and show no signs of scoring or seizure. The mating of gudgeon pin and piston is considered good when the lubricated pin can be fitted by simple hand pressure and when the gudgeon pin in vertical position does not fall off.
- Check the clearance between gudgeon pins and conrod bushings and if necessary replace the bushings (for this see 01 3 3100 and for alignment 01 3 2900).

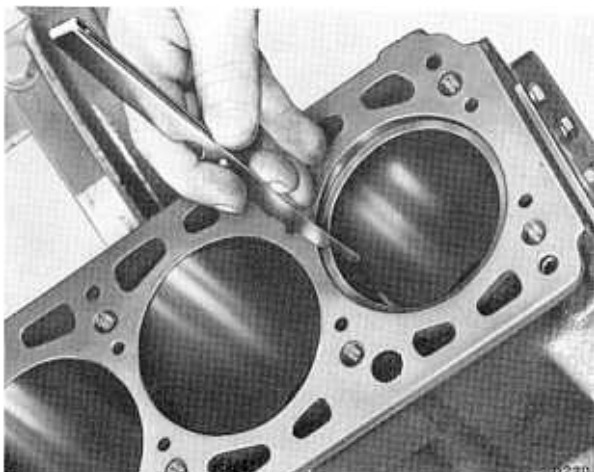

Fig. 01 3/22 - Checking piston ring gap.

- Check the piston ring gap by means of feeler gauge 88095770.
- Thoroughly clean piston ring grooves.

Note - If a piston has to be replaced, fit one of identical cylinder (ref. 1) and pin (ref. 2) class.



0364

Fig. 01 3/22 bis - Fitting conrod to piston.

- Fit pistons and pins with respective conrods; assembly should be carried out so that the exhaust valve mark (1) (smallest recess) on the crown of the piston is facing the number (2) stamped on the conrod.

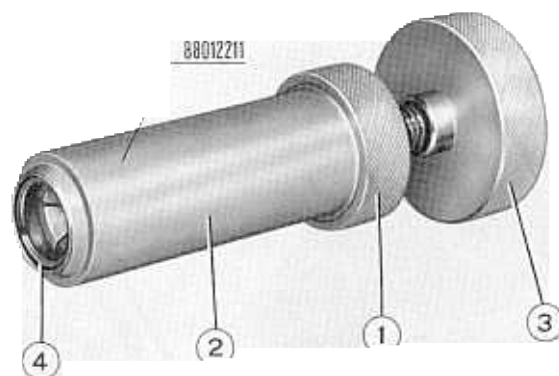

0143

Fig. 01 3/23 - Installer 88012211

- Use the installer 88012211 in the following way to refit the gudgeon pin circlips: unscrew the ring nut (1) and take the threaded pin (3) from the cylinder (2); fit the circlip (4) inside the cylinder and then refit the threaded pin, tighten the ring nut and screw in the threaded

pin (3) until the circlip has reached the position shown in the figure.

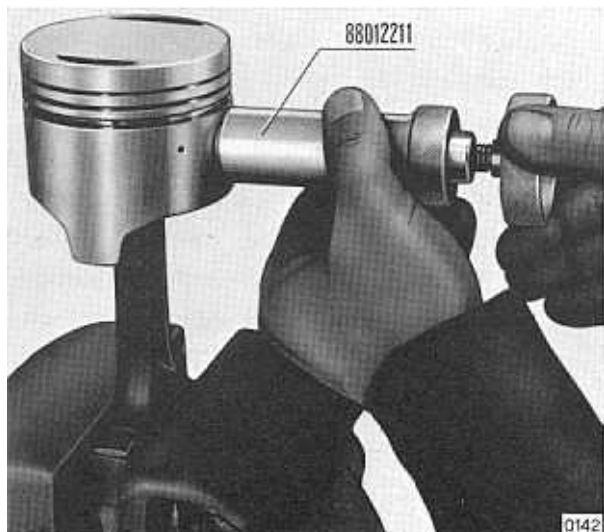

Fig. 01 3/24 - Fitting the gudgeon pin circlip.

- Grip the conrod assy in a lead-jawed vice, rest the installer 88012211 against the piston and screw in the threaded pin until the circlip has been fitted in its seat.

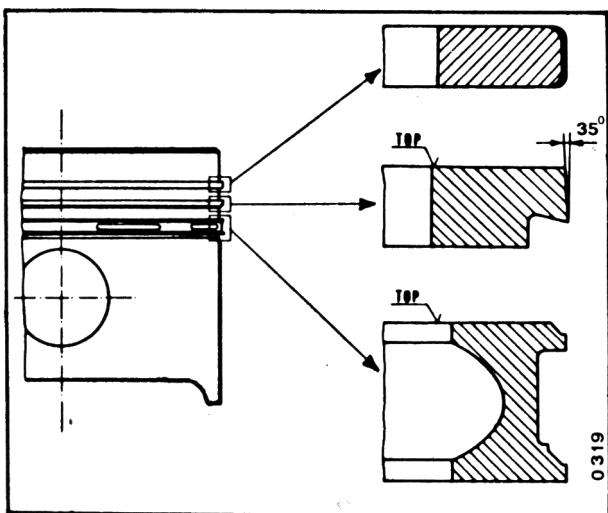

Fig. 01 3/25 - Fitting of piston rings.

- Refit the rings to the pistons by means of pliers 88012202 bearing in mind that the "Top" marking should face upwards.

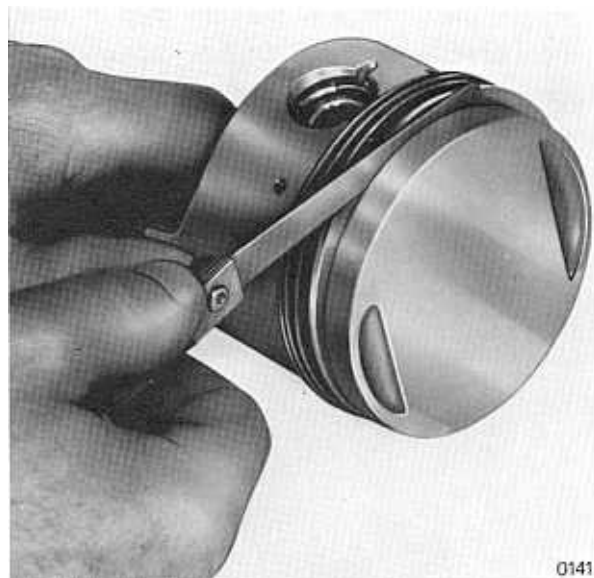

Fig. 01 3/26 - Checking the side clearance between pistons and rings.

- Using feeler gauge 88095770, check for excessive side clearance between each piston and its rings.

Refitting

- Set the engine on the stand with the cylinder surface facing upwards, then turn the flywheel and bring the gudgeon pins of pistons 1 and 4 to bottom dead centre.

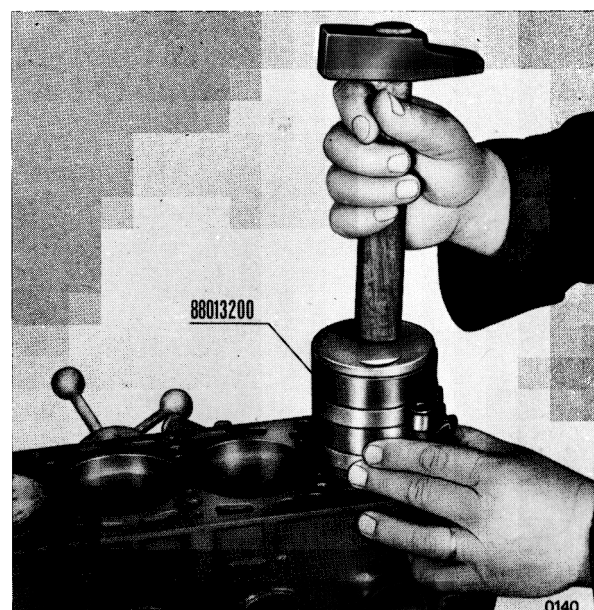

Fig. 01 3/27 - Installing the piston using ring compressor 88013200.

Set the piston rings so that the gaps between them are staggered at 120°, lubricate pistons 1 and 4 and, using compressor 88013200, install them in their respective cylinders, being sure that the numbers stamped on the conrods face the opposite side to the ancillary units shaft (as per the figure below).

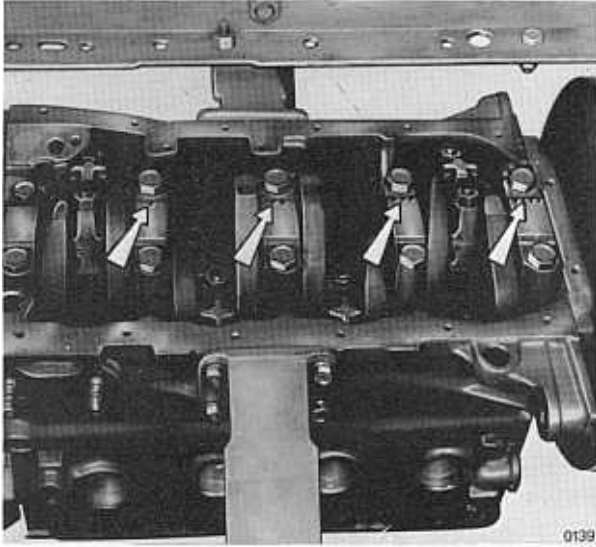

Fig. 01 3/28 - Setting of conrods on cylinder block.

- With the cylinder block in this new position, check the clearance between crankpins and bearing shells using the Plastigage.

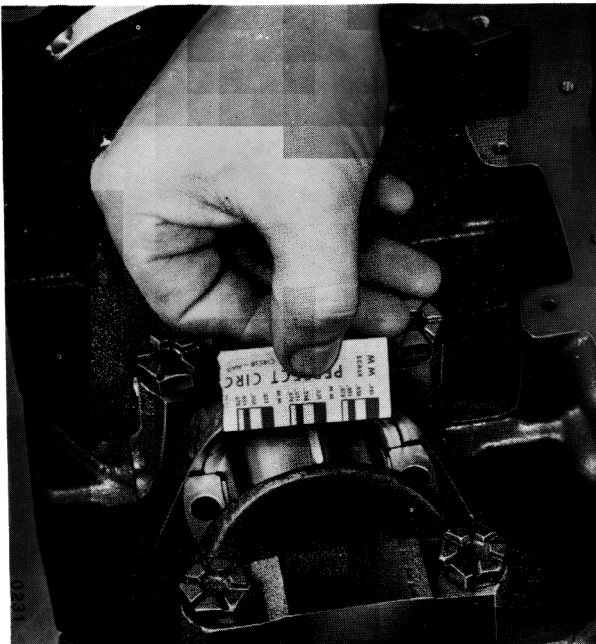

Fig. 01 3/29 - Checking clearance between conrod shell and crankpin by means of a "Plastigage".

- Remove all traces of oil from the bearing shell fitted to the conrod cap and from the crankpin.
- Apply a segment of "Plastigage" lengthwise to the crankpin axis using a light coating of grease to make it adhere, then fit the cap on the conrod and tighten the mounting nuts at the specified torque loading; during this operation avoid turning the crankshaft, otherwise the "Plastigage" would be damaged and it would become impossible to read clearance.
- Unfasten the nuts and remove the cap complete with bearing shell from the conrod, then measure the width of the flattened "Plastigage", which will either be stuck to the shell or to the crankpin, at its widest point.
- To read the thickness, use the scale stamped on the wrapper; the same scale also gives the corresponding clearance values in mm.
- Check the clearance on the other conrod; remove every trace of "Plastigage", lubricate and refit the caps of the two conrods at the specified torque loading.
- Turn the engine 180° on its stand and, working in the same way as before, assemble pistons two and three, complete the operation by checking bearing shell clearance and finally tighten the conrod cap mounting nuts at the specified torque.
- Refit the oil pump after replacing the gasket.
- Clean the crankcase-oil sump contact surfaces, fit a new gasket and then fit the sump.
- Turn the assembly 180° on the stand.
- Complete by carrying out the operations described at 01 3 0300, 01 3 0250, 01 3 0100 and 01 3 0010.

TOOLS REQUIRED

- 88095466 - Centesimal gauge
- 88095467 - Centesimal gauge
- 88095468 - Centesimal gauge
- 88012202 - Snap ring pliers
- 88012209 - Gudgeon pin driver

- 88095770 Feeler gauge
- 88012211 Gudgeon pin circlip installer
- 88013200 Piston ring retainer

§ 01 3 100

**REMOVING AND REFITTING THE
CRANKSHAFT FROM THE ENGINE AT THE
BENCH**

(Including removing and refitting the ancillary units drive shaft, and the flywheel and carrying out relative checks).

Carry out the operations described at 01 3 0010, 01 3 0250, 01 3 0300 and 01 3 0910 and then *proceed as follows*:

Removing

- Fit flywheel retaining tool 88013347 and then use spanner 88091231 to unfasten the nut securing the sheave to the crankshaft and then remove the sheave.

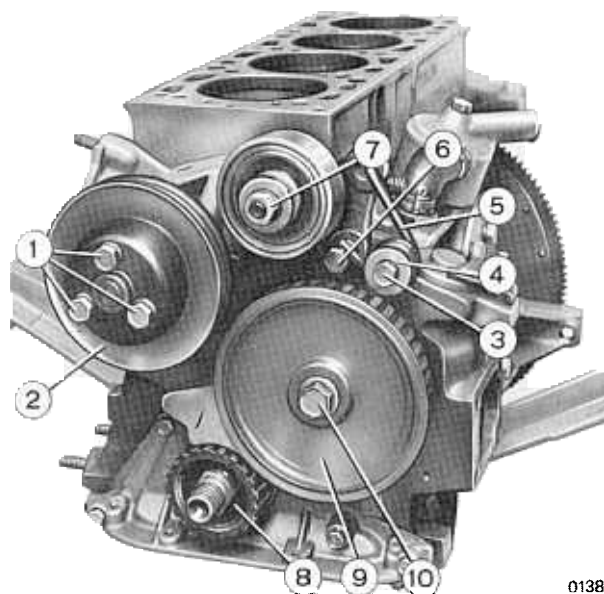

Fig. 01 3/30 - Front part of engine block with retainer 88013152 for ancillary units drive gear.

- Remove the bolts (1) and take off the sheave (2); then undo the securing bolts and remove the coolant pump.
- Remove the bolt (3) and spacer, the thrust

washers (4) and spring (5); take off the bolt (6) and nut (7) and remove the stretcher.

- Set retainer 88013152 between the crankshaft gear (8) and the ancillary units drive shaft gear (9), unscrew the bolt (10) and remove gear (9); then take off gear (8).
- Remove the oil breather pipe.

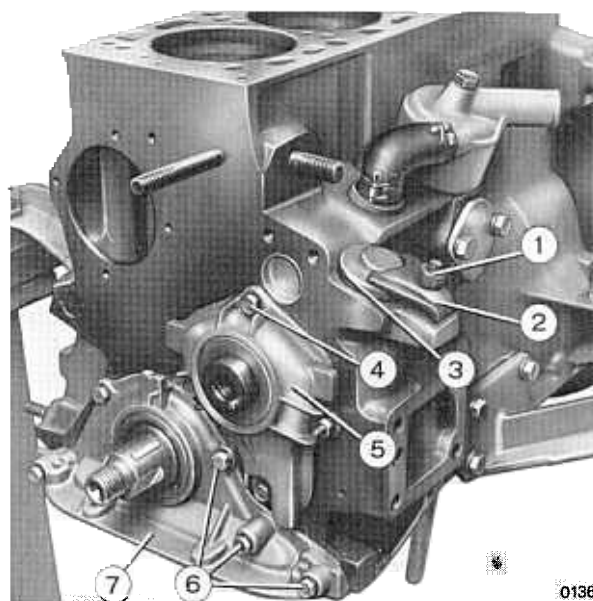

Fig. 01 3/31 - Removing ancillary units drive shaft from engine block.

- Remove nut (1), bracket (2) and cover (3).
- Unscrew bolts (4) and remove the oil seal support (5), then take off the retainer plate and remove the ancillary units shaft together with the oil pump drive gear.
- Remove the bolts (6) and take off the support (7).

Loosen the bolts holding the flywheel to the crankshaft, remove the tool 88013347 and then unfasten the bolts and remove the flywheel.

- Rotate the engine 180° on the stand.
- Remove the oil return pipe, take off the mounting bolts and remove the main bearing caps complete with shells.
- Remove the crankshaft together with thrust pieces and bearing shells.
- Check visually that the main bearings do not

show deep score marks or other defects; if faults are observed on the main journals, recondition them; if the fault is encountered on the bearing shell only and later controls show that the journals are acceptable, it is sufficient to replace the bearing shells alone.



Fig. 01 3/32 - Gauging the main journals.

– Use a* micrometer to check that the main journal diameters are acceptable.

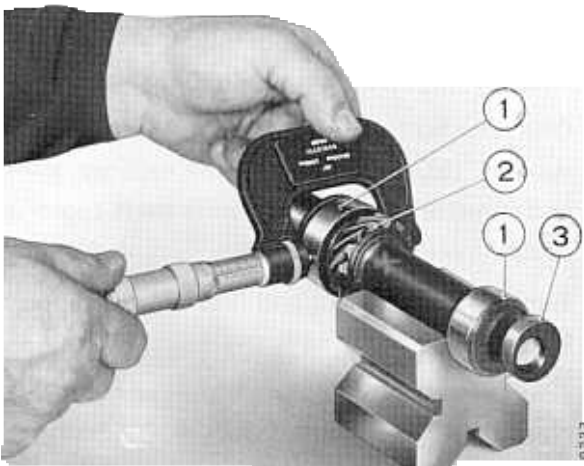

Fig. 01 3/33 Gauging ancillary units drive shaft journals.

– Check visually that the ancillary units drive shaft journals (1) are free from faults, then check the gauge with micrometer 88095466; also check that the bushings on the engine block do not require substitution (For this job see 01 3 1110).

- Then check that the ancillary units drive shaft gear (2) and the oil pump drive gear that meshes with it do not present chips or stepping; if they do, replace the worn part.
- Check that the flywheel ring gear teeth are not chipped or indented. If the indents are slight, simply dress the teeth with a smooth file or with grinder 88096770 and grinding wheel 88094494. Otherwise replace the ring gear according to 01 3 2310.
- Finally make sure that the flywheel surface where the clutch disc comes into contact with it is not scored. In the presence of light scoring, simply dress the surface with emery cloth (240 grit size). Otherwise reface the flywheel (see 01 3 2400).

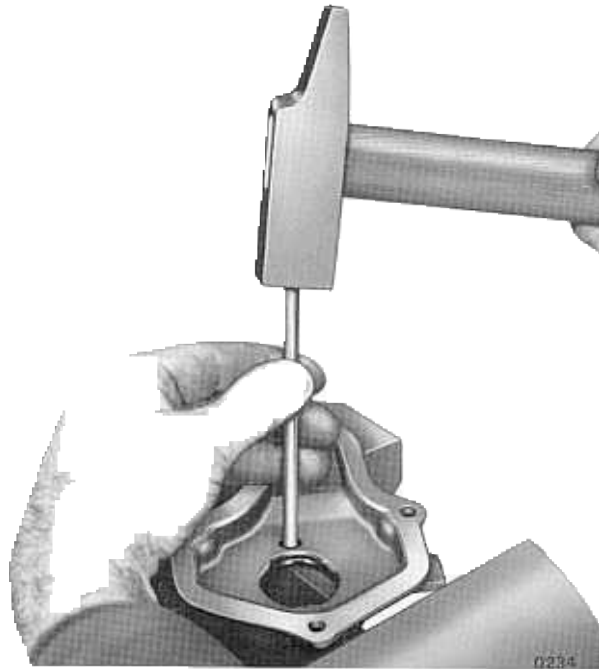

Fig. 01 3/34 - Removing the oil seal from the ancillary units shaft cover.

- Remove the crankshaft oil seals and the ancillary units shaft from their respective supports.
- Position the new oil seal on the rear support of the crankshaft and drive it home, inserting a plate of appropriate thickness between the oil seal and the press plunger; still using the press and with the aid of the installing tool 8801261, fit a new oil seal to the ancillary

units shaft support.

- Lift the engine block off the stand and clean it thoroughly with paraffin; it is particularly important to clean out the oilways using paraffin under pressure.
- Dry the engine block with compressed air and refit it to the stand.

Refitting

- Fit the main bearing shells and thrust rings to the engine block supports using grease as an adhesive for the rings; remember that the grooves on one side of the thrust rings should be turned towards the shoulder of the crankshaft.
- Clean the crankshaft thoroughly and refit it (for plug replacement or oilway cleaning, see 01 3 2100).

Check main bearing clearance *as follows*:

- Fit the bearing shells to the main bearing caps; remove all trace of oil from shells and pins and then apply a length of "Plastigage" calibrated string to the centre of the shells parallel with the crankshaft, using a slight coating of grease for purposes of adhesion.
- Fit the caps and bolts in accordance with the markings (part. 2 fig. 01 3/35).

The exception is the front cap which is easily identified by its different shape (due to the pump fitting). Then tighten the cap mounting bolts to the specified torque loading. During this operation, take care not to turn the crankshaft, so damaging the "Plastigage" and making clearance measurement impossible.

- Remove the bolts and take off the main bearing caps and the shells, then measure the width of the "Plastigage", flattened against the bearing shells or journal, at its widest point.
- To read the thickness, use the scale stamped on the envelope; this scale also shows the corresponding clearance values in mm.
- Remove all traces of "Plastigage" from the shells and journals, then lubricate with engine

oil, refit the caps and tighten them to the specified torque loading.

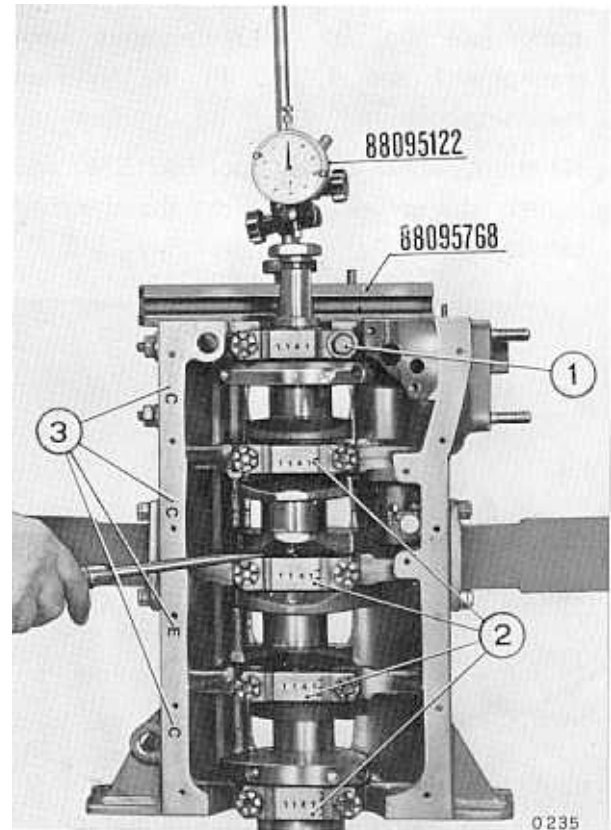

Fig. 01 3/35 - Measuring crankshaft end float.

- Turn the engine 90° on the stand, partly screw in the sheave mounting nut on the crankshaft, then set up support 88095768 and dial gauge 88095122.
- Using a screwdriver, move the crankshaft lengthwise in both directions and at the same time read the end float on the dial gauge.
- Check that float comes within the specified values. If they do not comply and the main journals have been refaced, oversize half rings will have to be fitted; otherwise, if the old half rings have been refitted, gauge their thickness to find out whether new standard or oversize half rings will have to be fitted to restore specified play.
- Remove the support and the dial gauge and remove the crankshaft nut, then turn the engine 90° on the stand and leave it so that the crankshaft is facing downwards.
- Fit the rear oil seal cover after fitting a new

gasket.

- Position the crankshaft with crankpins 1 and 4 at T.D.C., fit the flywheel so that the timing mark (see fig. 01 3/12) registers with crankpins 1 and 4, and fit the flywheel mounting bolts.
- Fit the flywheel locking tool 88013347 and tighten the securing bolts to the specified torque loading.

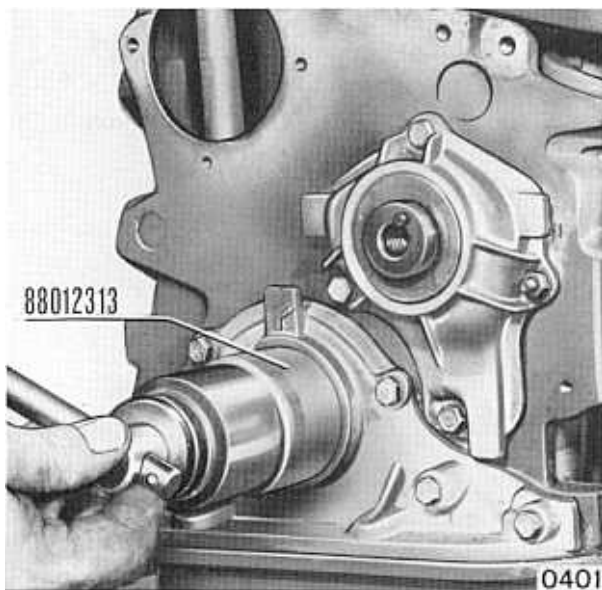

Fig. 01 3/36 - Fitting front oil seal.

Fit the oil seal cover after fitting a new gasket but do not tighten the securing bolts. Position the new oil seal gasket on the cover, then use installing tool 88012313 to drive the oil seal in, at the same time screwing the sheave mounting nut to the crankshaft.

Remove the tool 88012313, fit the timing belt drive gear to the crankshaft and tighten the oil seal carrying cover securing bolts.

Turn the engine 180° on the stand and fit the oil recovery pipe and oil pump drive gear after lubricating the shank.

Lubricate the ancillary units drive shaft bearings and then fit the shaft; fit the shaft retaining plate and the cover with oil seal after fitting a new gasket between cover and engine block.

- Turn the engine 180° and refit the oil vapour

breather pipe after fitting a new gasket; refit the cover (3) (fig. 01 3/31).

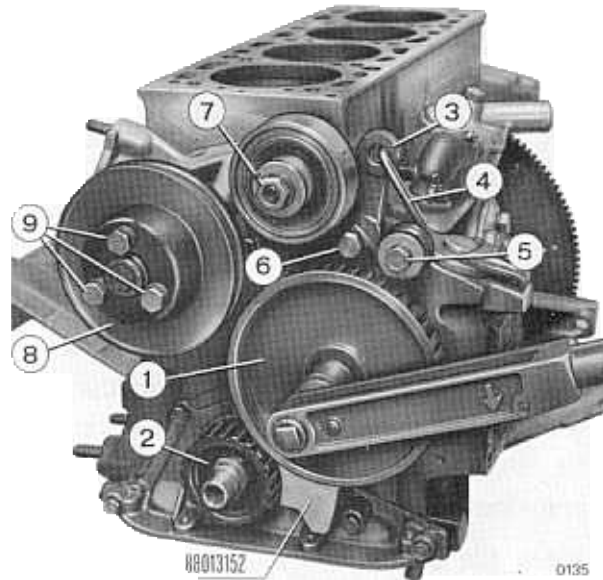

Fig. 01 3/37 - Front of engine block with ancillary units drive gear locking tool 88013152.

- Fit the gear (1) and insert tool 88013152 between this gear and gear (2), then tighten the gear (1) mounting bolt to the specified torque loading.
- Refit the belt stretcher (3) support and its spring (4), tighten the spring mounting bolt (5) and leave bolts (6) and nut (7) loose; push the stretcher in the direction of the arrow and partially tighten bolt (6) and nut (7).
- Refit the coolant pump after fitting a new gasket, then refit the sheave (8) and tighten the bolts (9).
- Refit the sheave to the crankshaft and tighten the mounting nut to the specified torque loading, then remove tool 88013347 and fit handles 88013344 on the flywheel.

Complete by carrying out the operations described at 01 3 0910, 01 3 0300, 01 3 0250, 01 3 0100 and 01 3 0010.

TOOLS REQUIRED

- 88013347 - Flywheel retaining tool
- 88091231 - Spanner
- 88013152 - Ancillary units drive shaft gear locking tool

- 88095466 - Micrometer
- 88096770 - Grinder
- 88094494 - Grinding wheel
- 88012161 - Installing tool
- 88095768 - Support
- 88095122 - Dial gauge
- 88012313 - Installing tool
- 88013344 - Handles

§ 01 3 1110

**SUBSTITUTING THE ANCILLARY UNITS
DRIVE SHAFT BEARINGS AND OIL PUMP
DRIVE GEAR BUSHING**

Proceed as follows:

- Turn the engine block on the stand, setting it with the front part turned upwards.



Fig. 01 3/38 - Removing the Ancillary Units Drive Shaft Front Bearing using tool 88012455.

- Using the two differently diametered ends of the installing-removing tool 88012455, drive the two ancillary units drive shaft bearings from the engine block.
- Clean the bearing seats thoroughly, making sure that the oilways are not clogged.

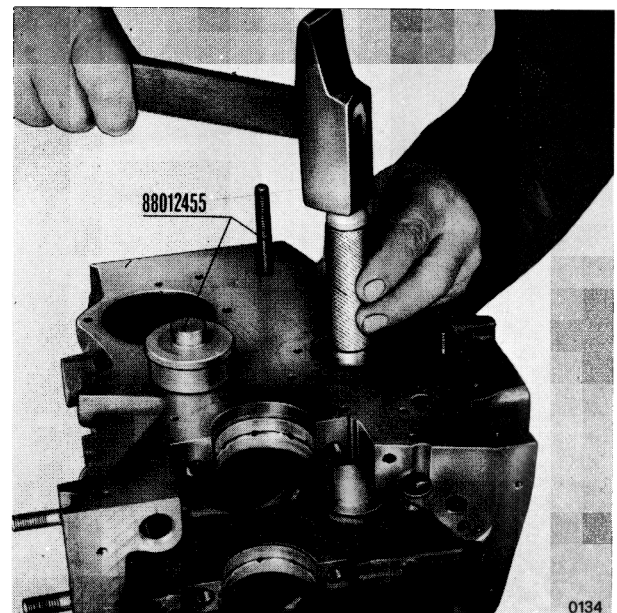

Fig. 01 3/39 - Installing the Ancillary Units Drive Shaft front bearing using tool 88012455.

- Using the installing tool 88012455, place the smaller diameter bearing in its seat and then fit the front bearing, making sure that the bearing oilways coincide with those on the crankcase.

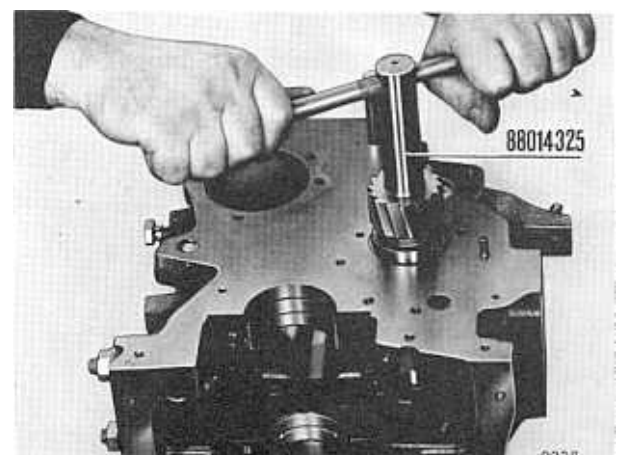

Fig. 01 3/40 - Reaming the Ancillary Units Drive Shaft Bearings

- Ream the I.D. of the bearings using reamer 88014325, then thoroughly clean the bearings and blow compressed air through the oilways to remove any impurities.
- Unscrew the nut (1) and remove the bracket (2) and the cover (3) (see fig. 01 3/31).



Fig. 01 3/41 - Removing and installing oil pump drive gear bushing.

- Using the removing-installing tool 88012456, drive out the oil pump drive gear bushing and then carefully clean the bushing seat and make sure that the crankcase oilway is not clogged.
- Turn the crankcase 180° on the stand and install the new bushing by means of installing tool 88012456, taking care to have the bushing hole coincide with the crankcase oilway.

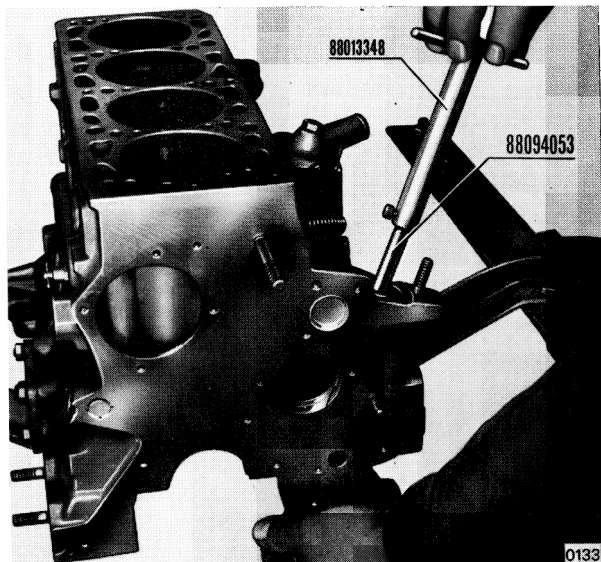

Fig. 01 3/42 - Reaming oil pump drive gear bushing with adjustable reamer 88094053 and handle 88013348.

- Ream the I.D. of the bushing using adjustable reamer 88094053 and handle 88013348 so that clearance between the oil pump drive gear shank and the bushing is as specified.
- Clean the bushing thoroughly and blow compressed air into the oilways to remove any impurities, then refit cover (3) (see fig. 01 3/31).

TOOLS REQUIRED

- 88012455 - Removing-installing tool
- 88014325 - Reamer
- 88012456 - Removing-installing tool
- 88094053 - Adjustable reamer
- 88013348 - Handle.

§ 01 3 2100

CLEANING THE CRANKSHAFT OILWAYS

Proceed as follows:

- Lock the crankshaft in lead-lined vice jaws, then use a suitable punch to remove the crankshaft oilway plugs.
- Wash down the crankshaft with paraffin and carefully clean the oilways using a special tube brush soaked in trichloroethylene so as to remove any possible trace of scales.
- Re chamfer the plug seats using cutter 88014326 and handle 88013348.

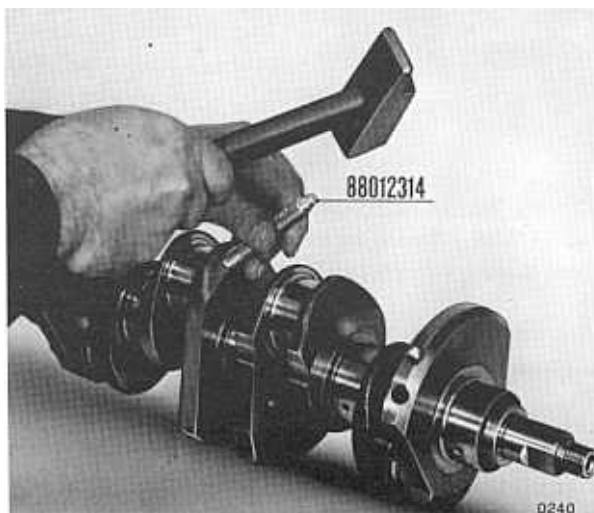

Fig. 01 3/43 - Fitting crankshaft oilway plugs with tool 88012314.

Fit the new plugs using installing tool 88012314 and then use the punch to make a number of safety crimps on the plug seats.

TOOLS REQUIRED

- 88014326 - Grinder
- 88013348 - Handle
- 88012314 - Installing tool

§ 01 3 2300

CHECKING THE FLYWHEEL

Prior to refacing the flywheel, carry out the following checks:

- Lie the flywheel on a surface plate with the clutch mating surface facing upwards.

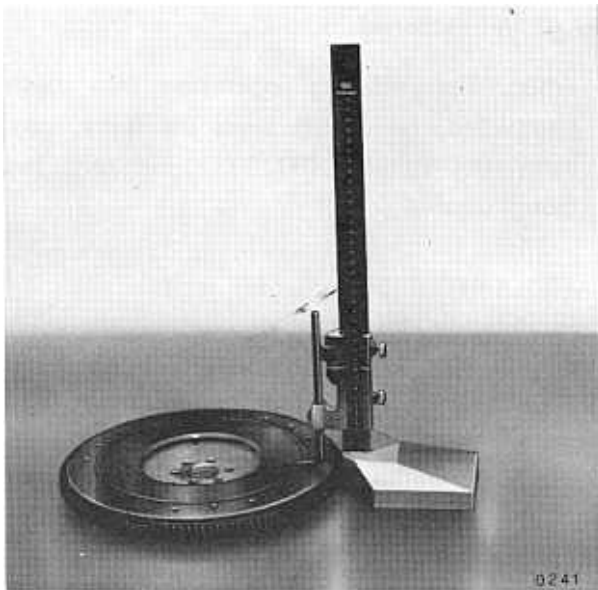

Fig. 01 3/44 - Gauging flywheel depth.

- Zero set the surface gauge 88095830 on the surface plate and read flywheel depth by lifting the surface gauge pointer to the level of the clutch disc resting surface.
 - Check whether value X shown by the surface gauge is the same as dimension "A" shown in the specifications, or whether X is smaller than A.
- If they are equal, the flywheel has not

previously been refaced and the operation can therefore be carried out to the minimum permissible dimension; if X is smaller than A, the flywheel has already been refaced and any further stock removed must correspond to the difference between the dimension gauged and the permitted minimum. It goes without saying that should the dimension gauged be close to the permitted minimum, then the flywheel cannot be further refaced and requires replacement (see 01 3 2400).

- To determine the thickness of the stock to be removed from the flywheel once these checks have been carried out, measure the scoring depth and then calculate how much has to be removed to eliminate marks.

It is obvious that if score marks cannot be eliminated without going beyond the minimum permissible dimension, the flywheel will have to be replaced.

TOOLS REQUIRED

- 88095830 - Surface gauge

§ 01 3 2310

REPLACING THE FLYWHEEL RING GEAR

Proceed as follows:

- Place the flywheel on the press table with the clutch disc mating surface facing downwards and the ring gear resting on approximately 5 cm metal blocks corresponding to the four recesses in the flywheel circumference.
- Apply the press plunger to the centre of the flywheel and drive off the ring gear, then thoroughly clean the ring gear seating.
- Heat the new ring gear in an oil bath to a temperature of 80°C and then position it on the four blocks with the inside diameter chamfer facing upwards.
- Present the flywheel to the ring gear, apply

the press plunger to the flywheel centre and install the ring gear on the flywheel.

- When the operation is completed, swill the flywheel in paraffin to remove all traces of oil.

§ 01 3 2400

REFACING THE FLYWHEEL

After checking the flywheel (see 01 3 2300), proceed as follows:

- Withdraw the clutch dowels from the flywheel, apply spindle 88023031 and secure it with the flywheel mounting bolts. Then fit a driving dog and pin to the spindle. To reface the clutch mating surface so that it is perfectly perpendicular to the rotation axis.
- Grip a cylindrical or hexagonal rod of diameter 25-30 mm and length 150-200 mm in the lathe self-centering chuck, incline the adjustable saddle of the lathe 30° and proceed to machine a tapered tip that is in perfect line with the horizontal axis of the lathe.
- Check the alignment by moving the live centre to the point where it is in contact with the tapered tip.

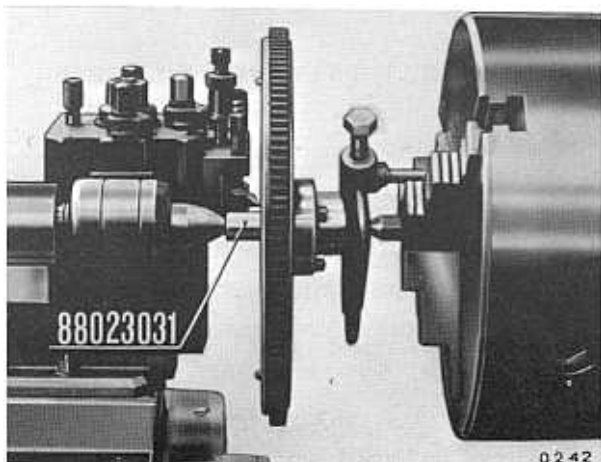

Fig. 01 3/45 - Refacing the flywheel.

- Set the flywheel complete with spindle 88023031 and driving dog on the lathe and reface the clutch disc mating surface until any scoring marks present on the surface have been eliminated; bear in mind that dimension

B shown in the figure below should be less than the figure indicated in the respective technical specifications.

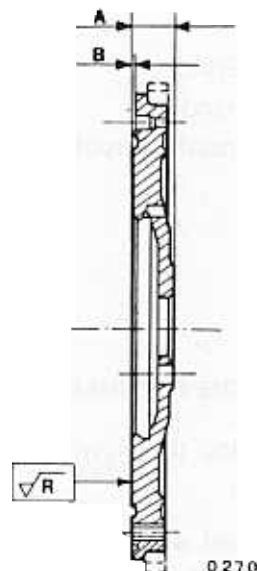

Fig. 01 3/46 - Flywheel

- When the refacing operation has been completed, remove it from the lathe, take away the spindle 88023031 and refit the clutch dowels.

TOOLS REQUIRED

- 88023031 - Spindle

§ 01 3 2600

REPLACING THE ENGINE BLOCK PLUGS

Proceed as follows:

- Using an appropriate tool, remove the plug to be substituted and thoroughly clean its seating in the engine block.



Fig. 01 3/47 - Fitting engine block plug using installing tool 88012043.

- Fit the new plug by means of installing tool 88012043.
- Proceed similarly when substituting the other plugs.

TOOLS REQUIRED

- 88012043 - Installing tool.

§ 01 3 2800

REBORING THE CYLINDERS

Proceed as follows:

- Measure the cylinder bore with gauge 88095094 and decide what oversize value will be needed to eliminate ovalization and score marks; then collect the pistons to be fitted.
- Install the cylinder block on boring machine 88096001 and clamp it to the surface with the brackets provided; then true the cylinder with the machine spindle.
- Check the dimension of each piston with gauge 88095468 and sum this with the specified clearance; then rebores the cylinder, leaving 0.020-0.030 mm. stock for the finishing operation.
- Remove the cylinder from the boring machine

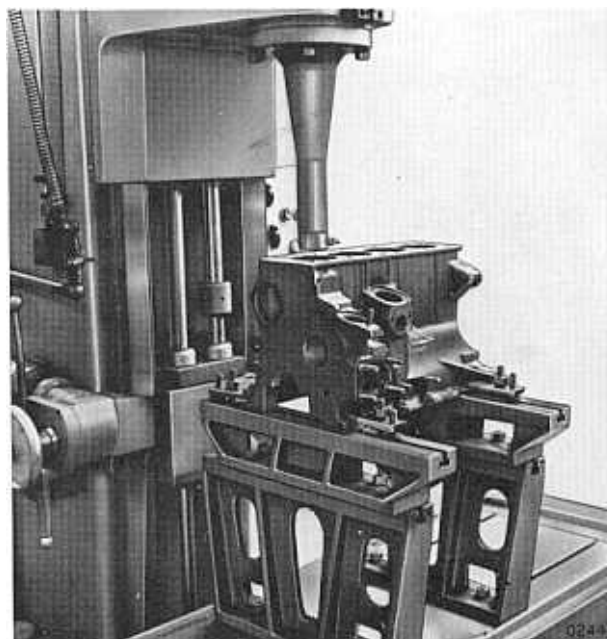

Fig. 01 3/48 - Rebores the cylinders.

and carry out the finishing operation with hone 88016318 which is part of kit 88016308.

- Clean the cylinder block thoroughly with paraffin and compressed air.

TOOLS REQUIRED

- 88095094 - Bore gauge
- 88096001 - Boring machine
- 88095468 - Gauge
- 88016318 - Hone

§ 01 3 2900

CHECKING CONNECTING ROD ALIGNMENT

Proceed as follows:

Stage 1 (checking small end and big end axes for parallelism):

- Grip the conrod to be checked in a vice provided with lead covered jaws, fit the mandrel 88015231A to the big end bearing and tighten the cap securing nuts to the specified torque loading.

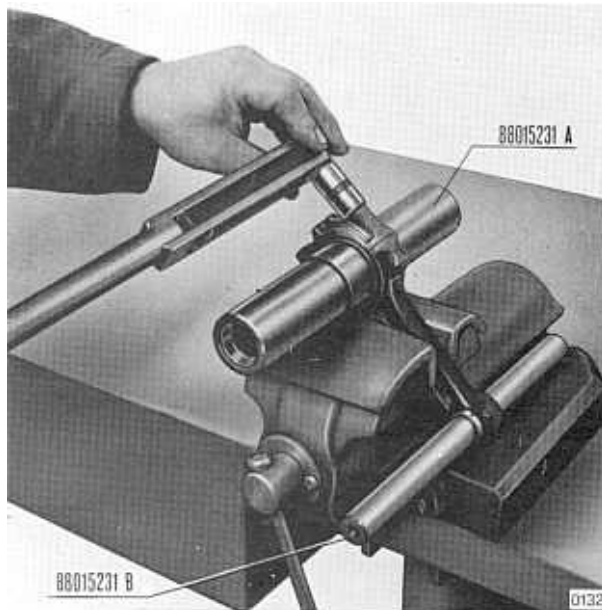

Fig. 01 3/49 - Fitting mandrels 88015231A and 88015231B at the big and small end respectively.

Fit spindle 88015231B in the small end bushing to the point where it rests against the side surface.

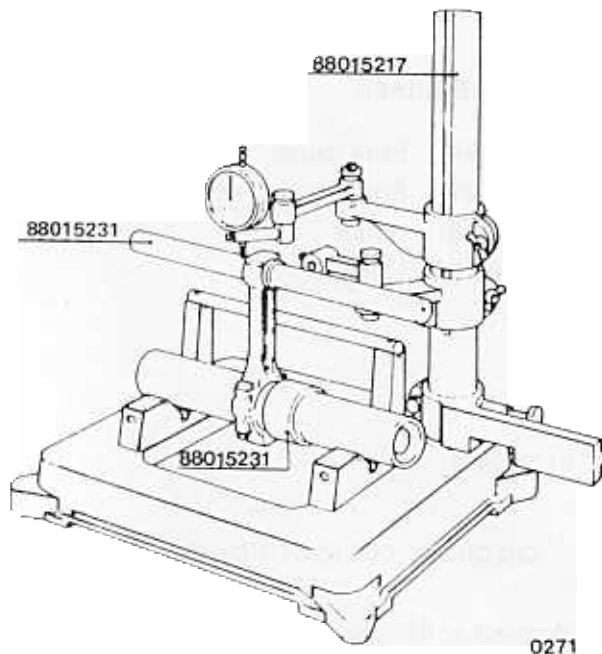

Fig. 01 3/50 - Conrod location on Fixture 88015217 to check conrod small end and big end axes for parallelism.

- Locate the conrod complete with mandrels on fixture 88015217, then set the gauge so that its stem falls vertically to the centreline of the fixture's V-shaped rests and touches the

mandrel 88015231 in the vicinity of the small end.

- Swing the conrod and zero-set the dial gauge at the maximum excursion, slide the conrod about 60 mm on the fixture's V-shaped rests; then swing the conrod again and check the maximum reading of the dial pointer, bearing in mind the direction it moves with respect to zero; the reading corresponds to the parallelism error between conrod small and big end axes. If the figure exceeds the specification, the conrod stem should be straightened by means of the hand press 88016203, which should be used on the right or left side according to the dial pointer shift. Then repeat the checking operation.

Stage 2 (checking conrod small and big end axes for coplanarity).

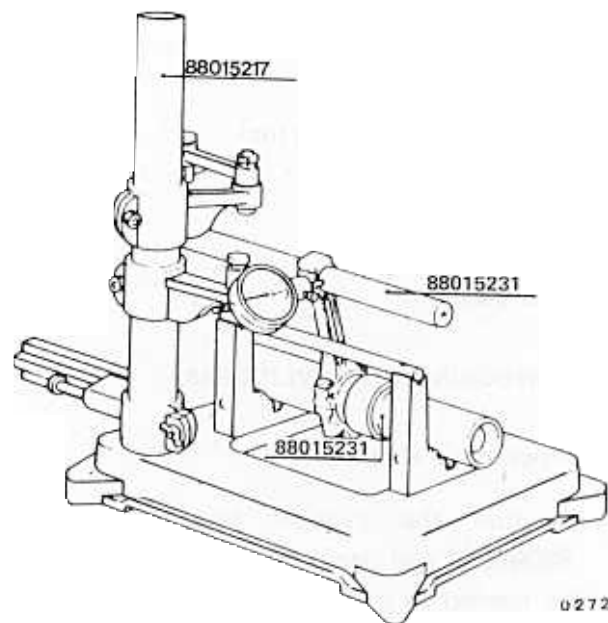

Fig. 01 3/51 - Checking conrod small and big end axes for coplanarity.

- Locate the conrod complete with mandrels on fixture 88015217, resting the stem against fixture horizontal axis 1; then position the dial gauge so that its stem contacts mandrel 88015231 close to the small end and preloads the gauge; zero-set the instrument at the above position.
- Slide the conrod about 60 mm on the

fixture's V-shaped rests and check on how much and in what direction the gauge pointer moves; the reading should not exceed the specification; if it does the conrod stem should be straightened on the basis of the direction in which the gauge pointer moved. When the straightening operation has been carried out, repeat the checking operation.

TOOLS REQUIRED

- 88015231 A - Big end mandrel
- 88015231 B - Small end mandrel
- 88016203 - Hand press
- 88015217 - Conrod fixture

§ 01 3 3100

REPLACING CONNECTING ROD SMALL END BUSHING

Proceed as follows:

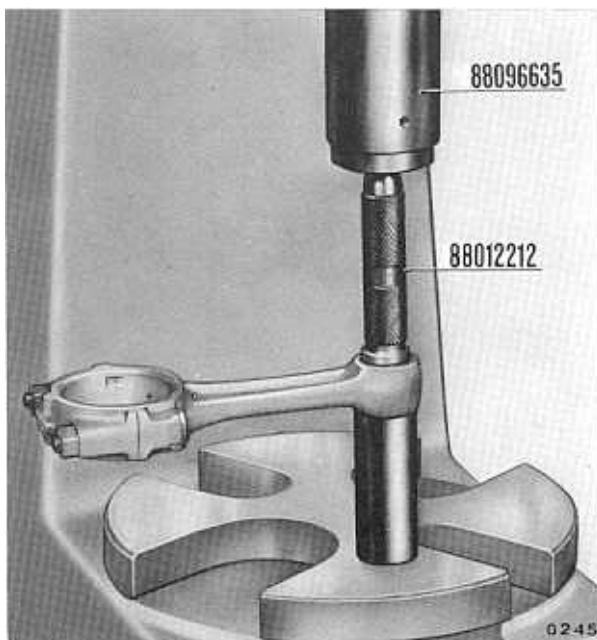

Fig. 01 3/52 - Driving off the conrod small end bushing.

- Using a press and installing-driving tool 88012212, remove the bushing requiring replacement.

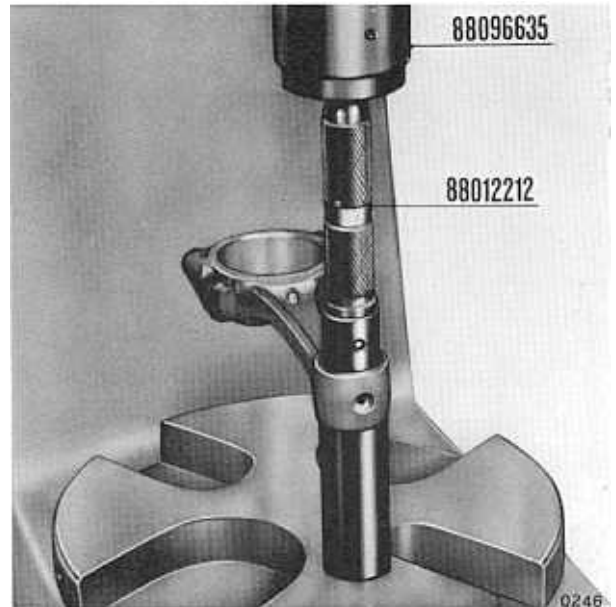

Fig. 01 3/53 - Installing the conrod small end bushing.

- Using tool 88012212, install the new bushing, making sure that the lubrication hole registers with that in the conrod small end.
- Using the small conrod lathe, reface the bushing inner diameter in accordance with specifications; remember that during the refacing operation, the tool leaves tiny tips that will be flattened by the gudgeon pin as soon as the engine is started. Clearance between pin and bushing is thus increased; to avoid this inconvenience, leave a few microns of stock when refacing the bushing and finish the work with rolling mandrel 88014203. (After replacing the small end bushing, it is good practice to check alignment as described at 01 3 0290).

TOOLS REQUIRED

- 88012212 - Installing-driving tool
- 88013203 - Rolling mandrel

CHAPTER 4

IGNITION

§ 01 4 0100

SETTING THE IGNITION DISTRIBUTOR (MARELLI S144G)

Proceed as follows:

- Swill the distributor with petrol and dry by air pressure.
- Grip the distributor in a lead-jawed vice, remove the mounting screws and take off the cap.
- Dress the rotor contact and the outside and inside contacts of the cap with fine abrasive paper.
- Check the breaker points for burning, holes or excessive wear and if required replace the set; if rust marks only are noted, remove them with a smooth file.



Fig. 01 4/1 - Checking the breaker points.

- Using feeler gauge 88095770, check that the breaker points gap complies with the specification; if it does not, slacken screws (1)

and move the fixed contact (2) by the amount necessary to establish the specified gap.

- Then test the ignition distributor at the bench (see 16 4 0400).

§ 01 4 0300

OVERHAULING THE IGNITION DISTRIBUTOR, INCLUDING FINAL BENCH TEST (MARELLI S 144 G)

Proceed as follows:

- Swill the outside of the distributor with petrol and dry with compressed air.
- Grip the distributor in a lead-jawed vice.

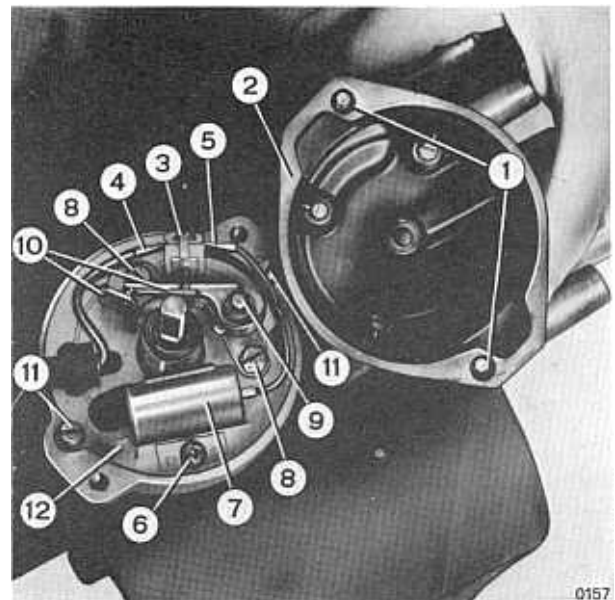

Fig. 01 4/2 Ignition distributor contact set.

- Remove screws (1), take off the distributor cap (2) and check it for cracks.
- Remove the rotor arm (ref 3 of fig. 01 4/1), slacken screw (3) and take off cables (4) and (5); remove screw (6) and take off the condenser (7), remove the screws (8), slip off

the seal (9) and remove the contacts set (10). Then remove screws (11) and take off the washer (12).

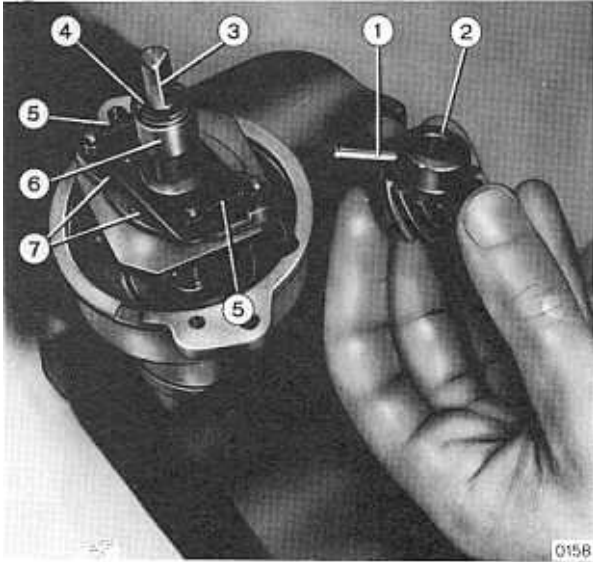

Fig. 01 4/3 - Ignition distributor "Automatic advance set".

- Using a suitable punch, drive off pin (1), remove gear (2) and slip off the complete spindle (3).
- Take off the seal (4), remove springs (5) from

the pins and contacts opening control (6), then remove the automatic advance weights (7).

- Check that the spring retaining pins are well secured and that clearance of the pins in the holes of the automatic advance weights is not excessive; also check that the shaft of spindle (3) shows no signs of seizure or excessive wear. If any of these faults is encountered, replace the complete automatic advance assembly.
- Check that the breaker points do not present burn marks or holes; if they do, replace the set.
- Clean all the parts removed thoroughly and refit them in the reverse order after applying a film of grease to all sliding or rotating parts.
- Adjust the breaker points gap according to specifications.
- Carefully clean the outside and inside contacts of the cap and then fit the cap to the distributor; when reassembly is completed, test the distributor at the bench (see 16 4 0400).

FUEL SYSTEM

§ 01 4 1000

OVERHAULING AND CHECKING THE WEBER 34 DATR 200 CARBURETTOR

Rich mixture and cut-off control operation

In the Weber 34 DATR 200, the rich mixture is controlled by a device sensitive to heat change in the coolant.

When the coolant temperature rises, the spring (8) shown in fig. 01 4/4 expands and makes yoke (5) go through one clockwork rotation which, by a system of levers, opens the rich mixture control valve.

When the engine stops and the temperature falls, the spiral spring contracts and the yoke rotates in the reverse direction, thus closing the throttle.

This movement is countered by screw (1) of fig. 01 4/13 which engages with sector (2) for smooth throttle insertion.

For the rich control device to insert completely, just push the accelerator pedal down (once only) so as to disengage screw (1) and permit the throttle to close; this operation should be carried out every time the engine is started cold and the rich mixture facility is required.

With the rich mixture control device inserted, a particularly rich mixture is obtained and this enables the car to be started easily when the engine is cold. As the engine heats up and revs increase, the vacuum created in the induction manifold leads to partial opening of the rich mixture control throttle by means of the cut-off device, thus reducing its effect.

After carrying out the bench tests on the carburettor as described at 16 4 1700, *proceed as follows:*

Take account of bench test results when deciding what jobs are necessary on the carburettor.

The faults encountered may be:

1) Rich mixture control mechanism not working

or working badly.

2) Throttles worn out or prone to sticking.

3) Fuel level not as prescribed.

4) Accelerating pump delivery does not conform to specification.

Rich mixture control

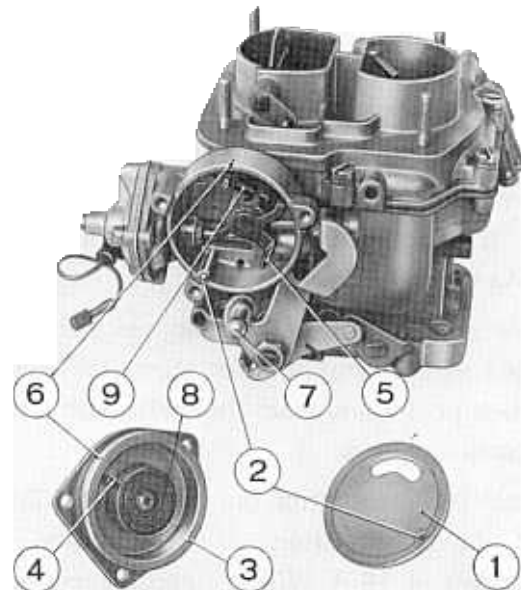

0161

Fig. 01 4/4 - Weber DATR 200 carburettor. Rich mixture control and choke cut-off side.

Take off the mounting screws and remove box (3).

- Check the various parts visually, particularly the coil (8) and spring (9), replacing warped or broken items.

Removing and refitting the throttles

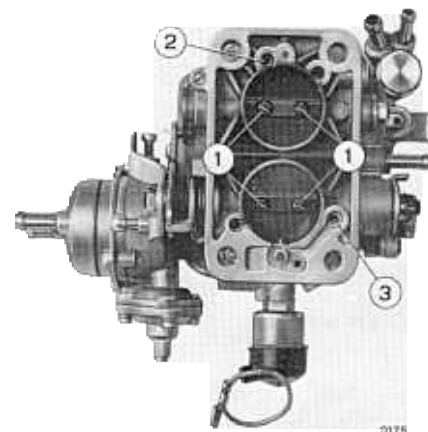

Fig. 01 4/5 - Bottom view of carburettor.

- Slacken the throttle opening setting screw so that the throttles rest against the choke.
- Remove the screws (1) securing the throttles to the shafts, and remove the throttles.
- Clean the shafts and fit the new throttles but without tightening the screws.
- Open the primary choke throttles fully by means of throttles control lever, then release the lever abruptly so that the throttles settle properly; repeat this operation a few times before tightening the screws that hold the throttle to the shaft.
- Use the same procedure for the secondary choke throttle.
- Make sure that the throttles are perfectly seated in the chokes, then crimp the screw threads protruding from the shafts with pliers or cutting nippers.
- Install the carburettor on fixture 88015359 and set the throttles air leak at rest as described at 16 4 1700, in accordance with specifications.

Fuel Level

- If preliminary testing shows that the fuel level does not conform to specifications, *proceed as follows*:
- Take off the float chamber cover.

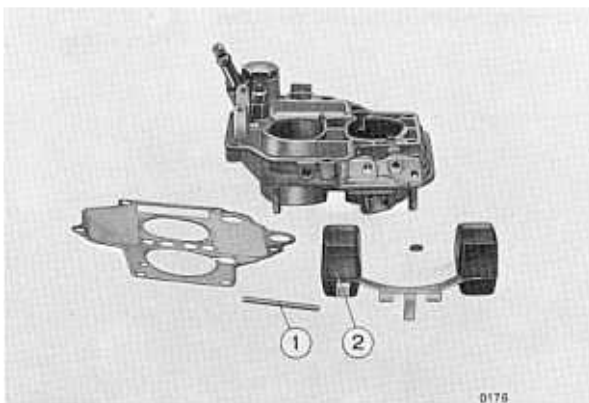

Fig. 01 4/6 - Cover and float.

- If the test has shown up a considerable difference in the level, remove the float pin (1) and replace the float (2). If the difference

is only slight, simply change the O ring between needle valve and cover with a finer or thicker type depending on whether the level is to be raised or lowered. If testing shows the needle valve sealing to be inadequate, replace it.

- Prior to refitting the float chamber cover, unscrew main and idling jets, wash them in trichloroethylene, blow through compressed air to dry, and check that the number indicating jet delivery stamped on each jet complies with the specification. Should the jet orifices be scored or the reference numbers illegible, test for the exact delivery value (see 16 4 2500).
- Check the fuel level as described at 16 4 1700.

Accelerating pump

If the carburettor bench test shows that delivery of the accelerating pump does not comply with the specification, *proceed as follows*:

- Remove the float chamber cover.

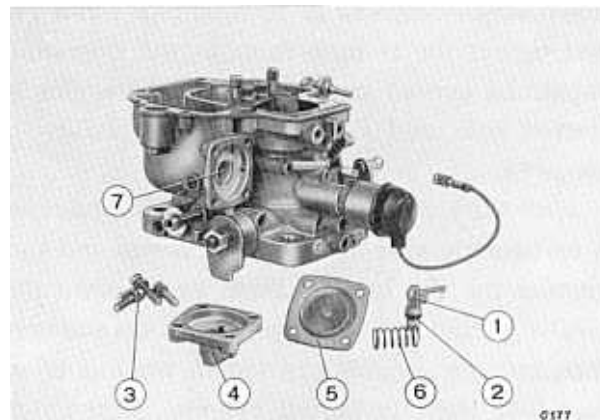

Fig. 01 4/7 Accelerating pump.

- Remove the pump jet (1) from the carburettor body and check that the rubber seal (2) is not worn; replace if necessary.
- Undo the fixing screws (3) and remove the pump cover (4) together with diaphragm (5) and spring (6).
- Check diaphragm (5) for wear and make sure that the diaphragm front-mounted cylinder

runs freely inside its housing (7); also check the diaphragm front-mounted spring (6); replace any worn parts.

Before refitting the accelerating pump, carry out the following checks:

Checking the Inlet Valve

- Fit the "D" type head jet to one hose of microgauge 88015363 and the "I" type head jet to the other hose; then connect jet support 88015371 to the "D" hose and fit a jet holder on which a master idling jet can be fitted in its turn. The delivery of the master jet will correspond to the pump inlet valve air leak and mark on the microgauge glass tube at the point where the "D" head jet has been fitted, the height reached by the fluid in the microgauge.
- Disconnect the support 88015371 and connect it to adapter 88015383 complete with "A" type end.

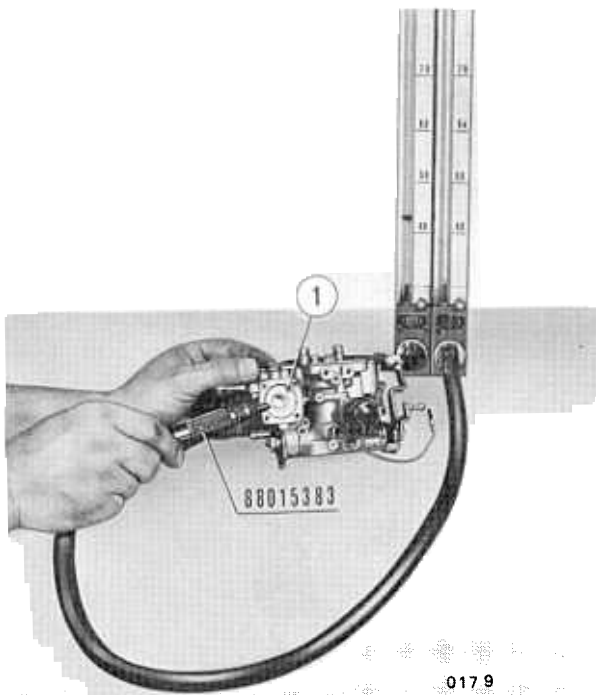

Fig. 01 4/8 - Checking accelerating pump inlet valve.

Feed the microgauge with air at the specified pressure then position the "A" end of the adapter on hole (1) where the fuel taken in by the pump passes; exert the pressure necessary

for the end to adhere perfectly to the hole, then check to see if the fuel level in the tube attained by the adapter leak coincides with the mark made earlier.

If it does not, blow compressed air through the valve to remove any impurities and repeat the check.

Checking the accelerating pump jet

- Disconnect the "A" end from adapter 88015383 and fit the "B" end.

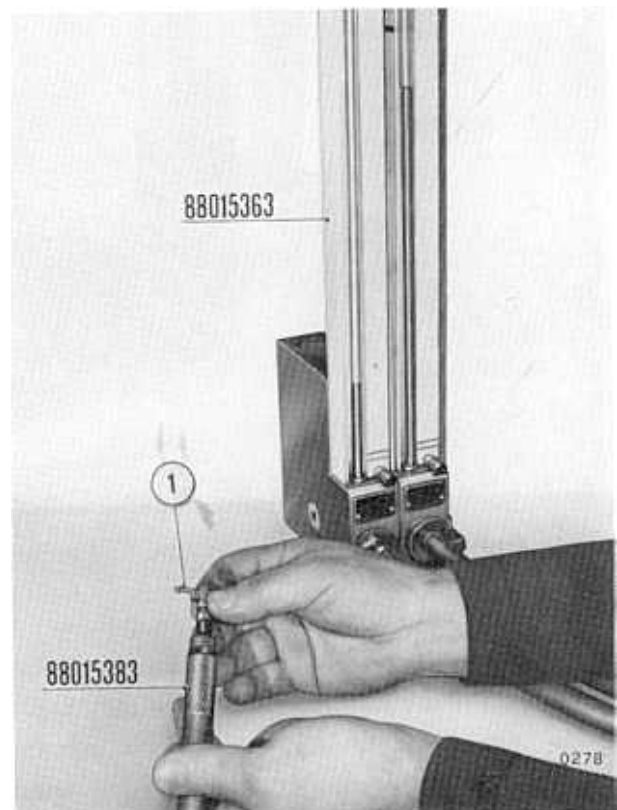

Fig. 01 4/9 - Checking accelerating pump jet delivery.

- Fit the "B" end to the bottom of the jet, making sure that the fit is perfect, then mark the fluid level on the glass tube corresponding to the "D" head jet.
- Disconnect the hose from the adapter 88015383 and fit it to jet support 88015371; then proceed as described above, i.e. compare the fluid level reached during the jet test with that reached by the master jet, whose delivery corresponds to the jet specification.

If the leak exceeds the specification, meaning

that the jet outlet diameter is irregular, replace the jet.

- Fit the adapter 88015383 complete with "B" end to the microgauge hose corresponding to the "D" head jet.

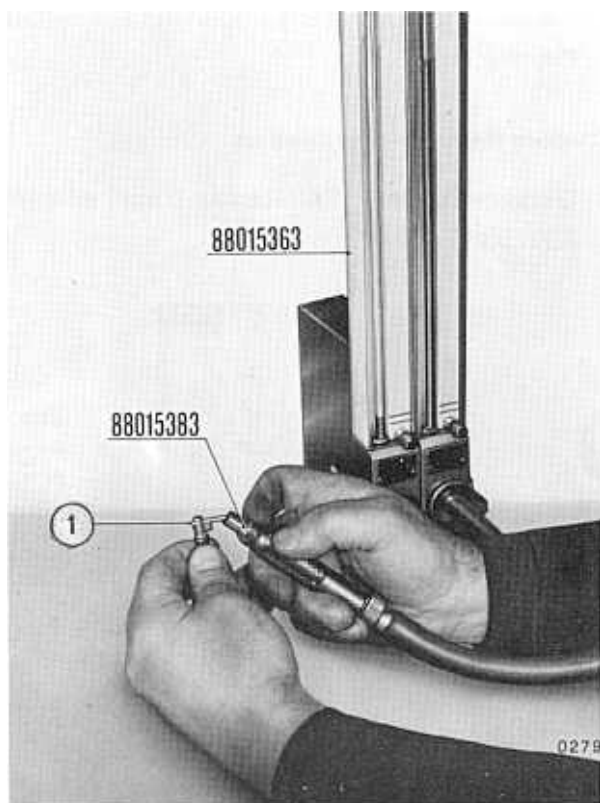

Fig. 01 4/10 - Checking the pump jet valve.

- Holding the jet vertically (the same position as when it is fitted to the carburettor), apply the adapter "B" end so that it adheres perfectly to the jet outlet. In these conditions, the leak on the corresponding microgauge column should be zero.
- Should a leak be noticed, replace the jet.
- Refit the accelerating pump with jet, but do not fit the float chamber cover for the moment.

Checking the secondary choke super-feed jet

Disconnect the adapter 88015383 and "B" end from the hose corresponding to the "D" head jet and fit it to the hose with "I" head jet.

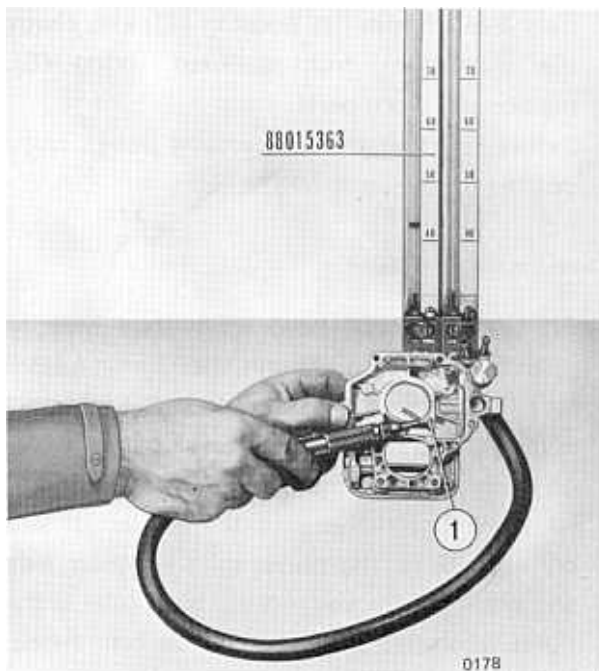

Fig. 01 4/11 - Checking Super-feed jet delivery.

- Position the adapter "B" end on the super-feed jet (1) and mark the level reached by the fluid on the column; then with a master jet and using a similar procedure to the previous one, check that the jet leak agrees with the specification, otherwise replace the float chamber cover.

Checking the Choke cut-off device

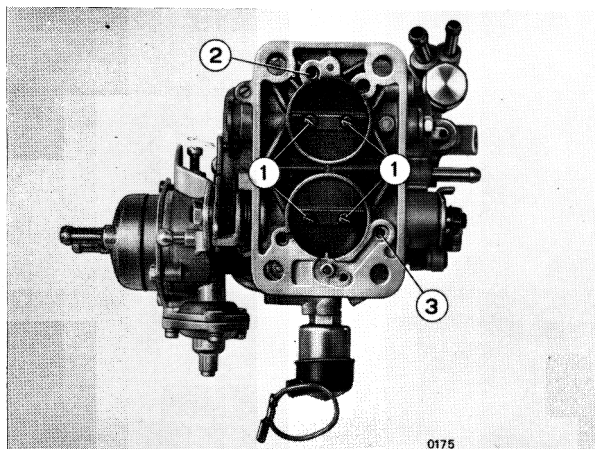

Fig. 01 4/12 – Bottom of carburettor.

- Tight fit the "B" end of adapter 88015383 to the choke cut-off device vacuum chamber and check that the microgauge column is not leaking. Should even the slightest of leaks be noted, either the vacuum chamber diaphragm

or the gasket (5) in the figure below are not perfectly tight.

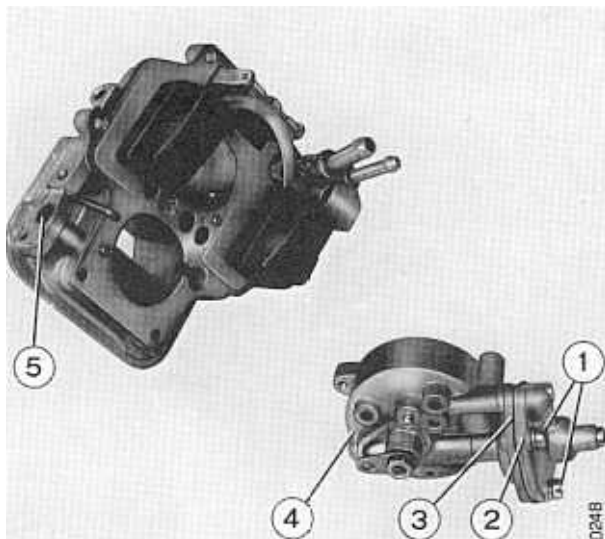

Fig. 01 4/13 – Choke cut-off device.

- Remove the screws (1), take off the cut-off device cover (2) and replace the diaphragm (3); then remove the fixing screws, take off the rich mixture control body (4) and replace the gasket (5).
- Refit the cut-off device and rich mixture control in the reverse order to removal then refit the float chamber cover to the carburettor and complete with the bench test as described at 16 4 1700.

TOOLS REQUIRED

- 88015359 – Carburettor fixture
- 88015353 – Microgauge
- 88015371 – Support
- 88015383 – Adapter

COOLING SYSTEM

§ 01 4 1300

GENERAL OVERHAUL OF COOLANT RADIATOR

Proceed as follows:

- Clean the outside of the radiator.
Test the radiator for tightness as follows:
- Make sure it is completely empty and if possible dry.

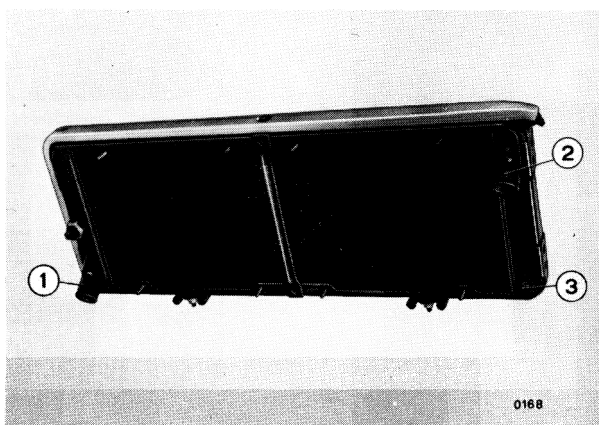

Fig. 01 4/14 - Radiator

- Using the expansion plugs included in kit 88015401, stop up coolant inlet and outlet ports (1) and (2); then introduce air at a

pressure of 0.98 Kg/cm² through the overflow hole (3) and dip the radiator into a tank already filled with water until the leak is detected.

- Unsolder the cover of the radiator top at the side or sides at which the leaks have been noted, wash out the tubes carefully with a jet of water and dry with compressed air.
- Carefully clean the areas where leaks have been detected, and the edges of the tank and cover with a flame and wire brush.
- If necessary, straighten out the tank cover and any tube gills that have been bent.
- Remove any rust from parts to be soldered using hydrochloric acid, then soft solder the areas where leaks have been noted and the tank cover.
- Repeat the tightness test to make sure that all the leaks have been eliminated.
- Clean the outside of the radiator with a wire brush to eliminate any remaining traces of paint.
- Paint the radiator with synthetic black enamel.

TOOLS REQUIRED

- 88015401 – Radiator tightness control kit.

LUBRICATION

§ 01 4 2500

OVERHAULING THE OIL PUMP

Proceed as follows:

Disassembling

- Grip the oil pump in a lead-jawed vice.

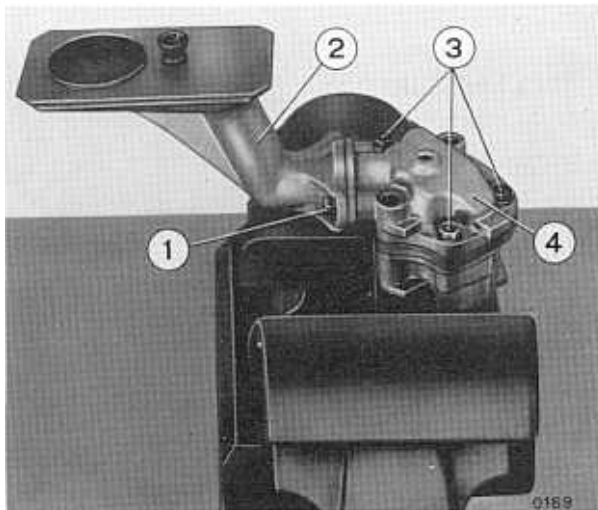

Fig. 01 4/15 - Oil pump.

- Removing the bolts (1) and take off the intake assembly (2); remove the bolts (3) and take off the cover (4).
- Remove the pump body from the vice.

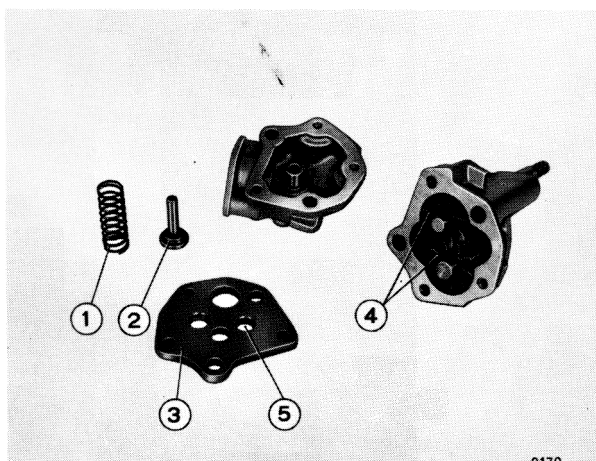

Fig. 01 4/16 - Internal components of the oil pump.

- Remove the spring (1), the relief valve (2) and the plate (3).
- Remove the gears (4) from the pump body.

Checking

- Swill the parts removed with paraffin and dry by air pressure.
- Inspect the gears for scoring or stepping and replace if necessary.

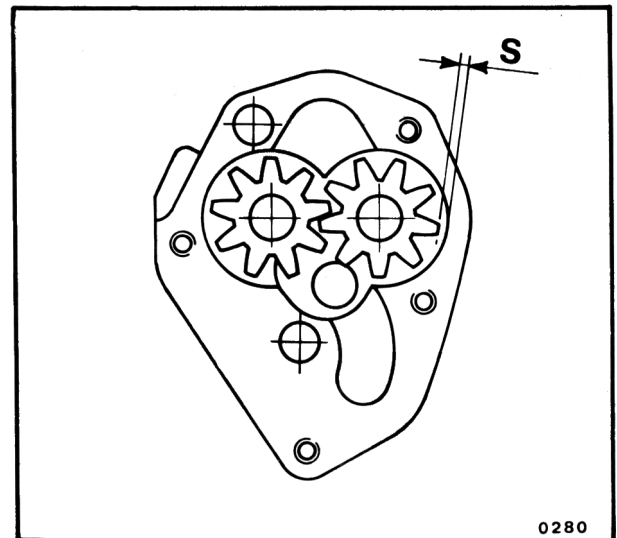

Fig. 01 4/17 - Checking clearance between gears and pump body.

- Refit the gears to the pump body and use the feeler gauge to make sure that the clearance "S" between gears and pump body is acceptable.

Excessive clearance could be caused by wear on the oil pump gear shaft or by ovalization of the guide hole on the pump body or of hole (5) on plate (3) (fig. 01 4/16); replace any parts found to be worn.

- Place the pump body complete with gears on V blocks 88095602 (on surface plate 88095621), then fit the dial gauge 88095122 on support 88095768 and gauge the end float between the gears and pump body surface.
- If the measurement, which corresponds to the axial play of the gears, is unacceptable, the cause might be excessive wear of the inner surface of the pump body or of the gear faces; obviously any used parts should be replaced.

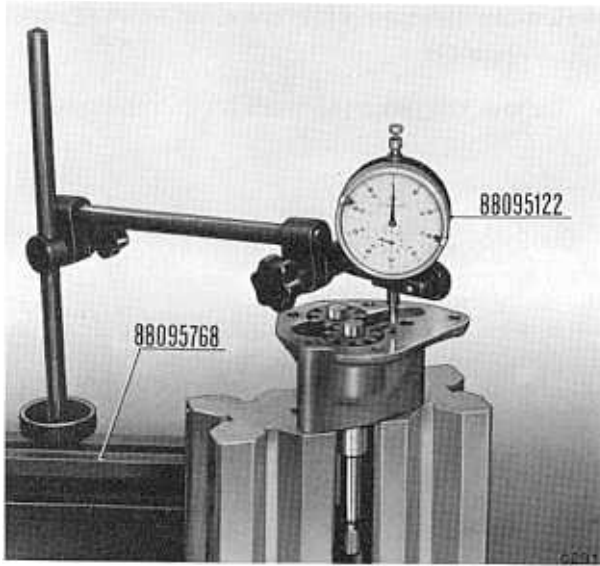

Fig. 01 4/18 - Measuring the end float between gears and pump body surface.

- Check that the pump body plate is not worn where it contacts the gears; also check that the relief valve seating is not scored or worn impairing its tightness; if it is, replace the

plate.

- Check that the relief valve sealing face is not defective and does not otherwise need replacement.
- Check the valve spring loading using tester 88095021 and replace it if it does not meet specifications.

Reassembling.

- Lubricate the inner parts and reassemble the oil pump in the reverse order to the removal.

TOOLS REQUIRED

- 88095602 – V blocks
- 88095621 – Surface plate
- 88095122 – Dial gauge
- 88095768 – Support
- 88095021 – Tester

CYLINDER HEAD

§ 01 4 2650

REMOVING AND REFITTING CAMSHAFT HOUSINGS FROM THE CYLINDER HEAD ON THE BENCH

Proceed as follows:

Removing

- Fit the camshaft gear retaining tool 88013151, slacken the securing bolts and remove the retaining tool.
- Detach the housing covers and gaskets, overturn the cylinder head and allow any oil residues to drain off.
- Unscrew the camshaft housing securing bolts and remove them along with the tappets.
- Take the tappets off the housings, being sure to place them so that they will be put back in exactly the same position at refitting.
- Carefully wash all parts removed with paraffin.
- Visually check that tappets and camshaft housing seatings do not show seizure marks or any undue wear that might require their replacement (disassembly and overhaul of a camshaft housing is described at 01 4 3400).
- Also check that clearance between tappets and their seatings is not excessive.

Refitting

- Carefully clean the cylinder head surfaces mating with the camshaft housings and fit the new gaskets.
- Lubricate the tappets and refit them in their seatings; then refit the camshaft housings on the cylinder head and tighten the mounting bolts to the specified torque loading.
- Fit camshaft gear retaining tool 88013151 and tighten the gear securing bolts to the torque loading specified and remove the tool.
- Refit the camshaft housing covers and

gaskets.

TOOLS REQUIRED

- 88013151 – Camshaft gear retaining tool.

§ 01 4 2700

DISASSEMBLING AND REASSEMBLING THE CYLINDER HEAD

(Including checking the cylinder head surface for flatness, valves, guides, valve seats and spring loading)

After carrying out the work described at 01 4 2650, *proceed as follows:*

Disassembling

- Detach the carburettor from the intake manifold.
- Remove the intake and exhaust manifolds with gaskets.
- Take out the plugs.

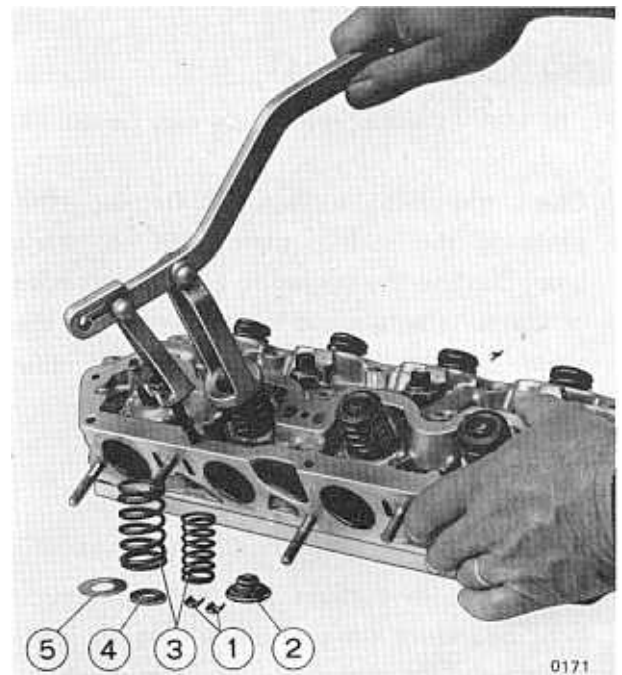

Fig. 01 4/19 - Disassembling the valve springs.

- Set the head on rest plate 88012040 and use tool 88012041 to load the springs, extract the cotter pins (1) and remove the upper collar (2), the springs (3), the lower collar (4) and the washer (5).

- Remove the valves from the guides and arrange them in the order in which they were mounted on the cylinder head.
- Use the wire brush 88014015 fitted to hand drill 88096925 to remove the carbon deposits from the combustion chambers and exhaust ducts. (To surface the cylinder head see 01 4 3300).

Checking the Cylinder Head for Flatness

- Clean the cylinder head to engine block mating surface.

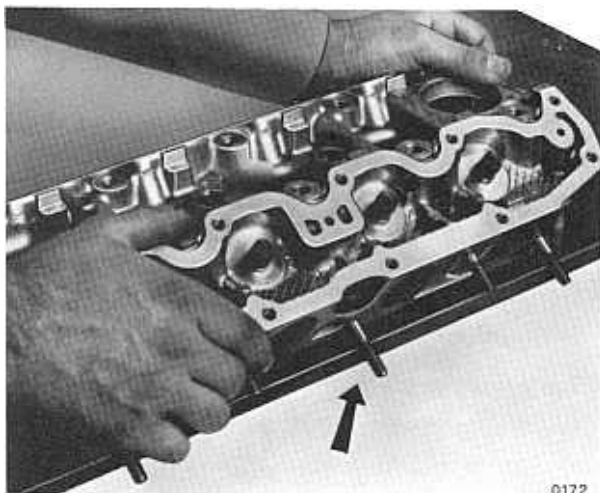

Fig. 01 4/20 - Checking the cylinder head for flatness.

- Check the head surface for flatness after smearing the surface plate with engineer's blue. Confine the operation to the outer edge of the surface to avoid interference from the studs holding the exhaust manifold. (To surface the cylinder head, see 01 4 3300).

Checking the Valves and Guides

- Scrape any carbon deposits off the valves.
- Check the valve stems for deep scorings or signs of seizure and also check that the valve sealing surface is not stepped and does not present signs of burning such that they would not be removed by refacing; valves presenting such faults should be replaced. (To reface valve seatings and valves see 01 4 2710).
- Visually check the valve guide inner diameter for scorings or signs of seizure. Using gauges

88015018, and 88015019 check the guide bore and replace any guide that is found to be worn. (To replace valve guides and reface seats see 01 4 3100).

Checking seats

- Check the valve seats for signs of burning or wear to the surface mating with the valves; any such conditions can be removed by refacing (see 01 4 2710) allowing of course for the permitted refacing limit.

Checking the springs

- Using the tester 88095021, check that the inner and outer springs are not fatigued.

Reassembling

- Refit the valves.

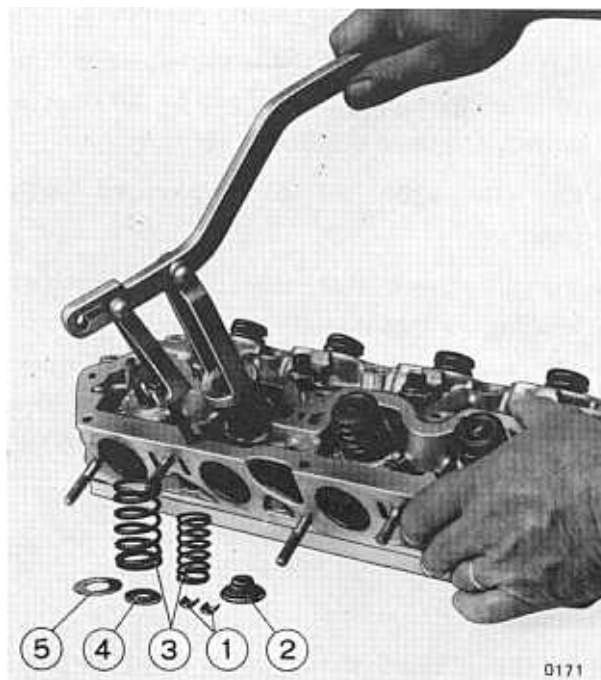

Fig. 01 4/21 - Refitting the valve springs.

- Set the cylinder head on the plate 88012040, fit the washers (5), the lower collars (4), the springs (3), and the upper collars (2).
- Compress the springs with tool 88012041 and then fit the cotter pins (1).
- Refit the remaining parts in reverse order to the removal, and replace the gaskets on the intake and exhaust manifolds.

Complete the procedure by carrying out the work described at 01 4 2650.

TOOLS REQUIRED

- 88012040 – Cylinder head rest plate
- 88012041 – Valve spring compressor
- 88014015 – Wire brush
- 88096825 – Portable drill
- 88015018 – Valve guide bore control gauge (8.01-8.02 mm.)
- 88015019 – Valve guide bore control gauge (8.03-8.04 mm.)
- 88095021 – Tester

§ 01 4 2710

REFACING VALVES AND SEATS

Note: The valve seat reference diameters ϕa and ϕs shown in the figure below, must remain unaltered after refacing so that the mating surface between valves and seats does not vary.

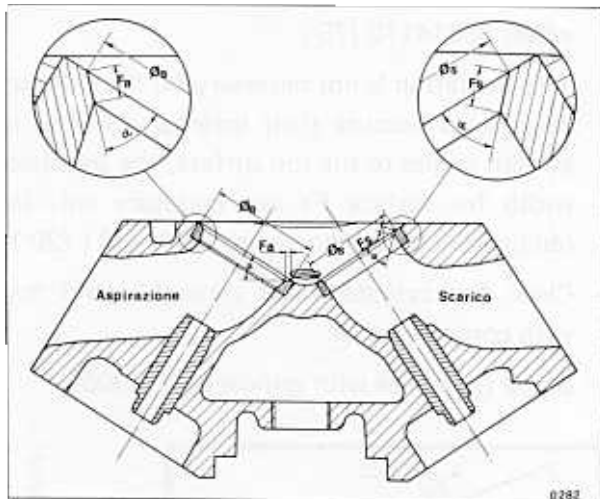

Fig. 01 4/22 - Intake and exhaust valve seats when new.

After carrying out the work described at 01 4 2700, proceed as follows:

Set the cylinder head on the workbench so that the valve seat to be dealt with is on the level.

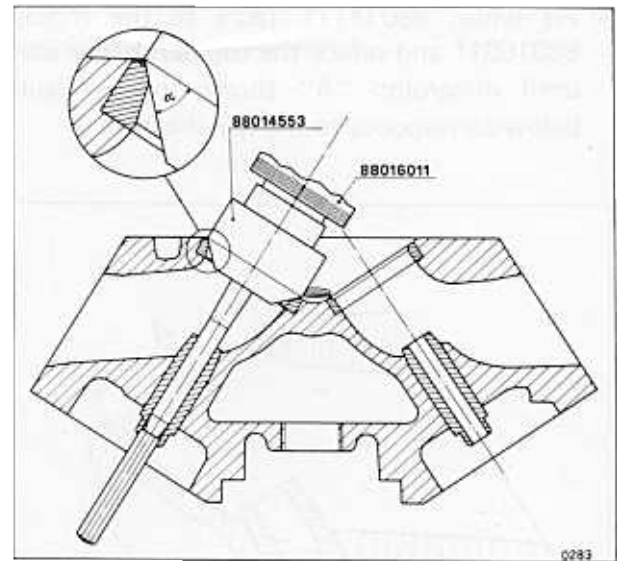

Fig. 01 4/23 - Refacing valve seats with portable grinder 88016011 and wheel 88014553

- Insert the 8.00 mm pilot stem forming part of the grinder outfit 88016011 in the valve guide concerned. Then fit the wheel 88014533 (45°) and reface the valve seat until the relevant faults are eliminated. Reface any other defective seats in the same fashion.

Note: When refacing seats, it is good practice to dress the wheel regularly using the dresser in kit 88016011; this will keep wheel taper correct.

- Restore the correct ϕa and ϕs (fig. 01 4/) because refacing will have made them greater than specifications; proceed as follows:

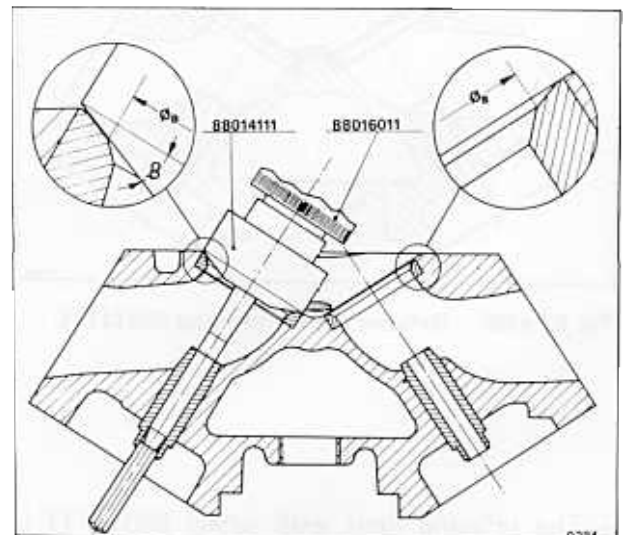

Fig. 01 4/24 - Reduction of ϕa and ϕs to initial values using grinding wheel 88014111.

Fit wheel 88014111 (20°) to the grinder 88016011 and reface the top part of the seats until dimension "A" shown in the figure below corresponds to the specification.

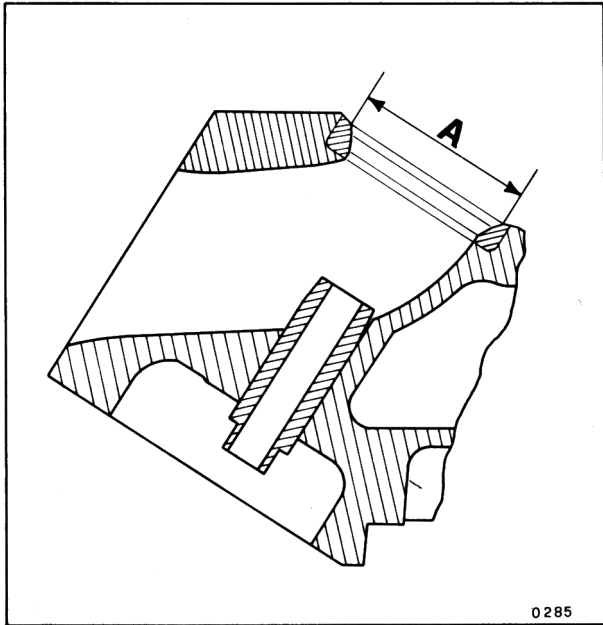

Fig. 01 4/25 - Reference diameter on the valve seat.

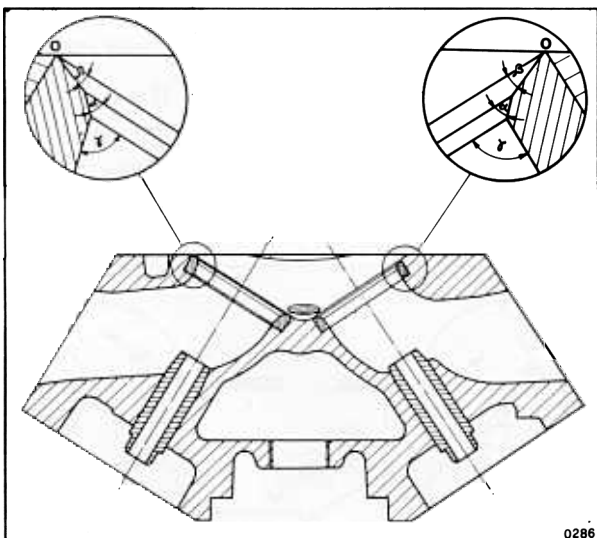

Fig. 01 4/26 Refacing limit with wheel 88014111.

The refacing limit with wheel 88014111 is reached when the operation reaches the very top of the seat.

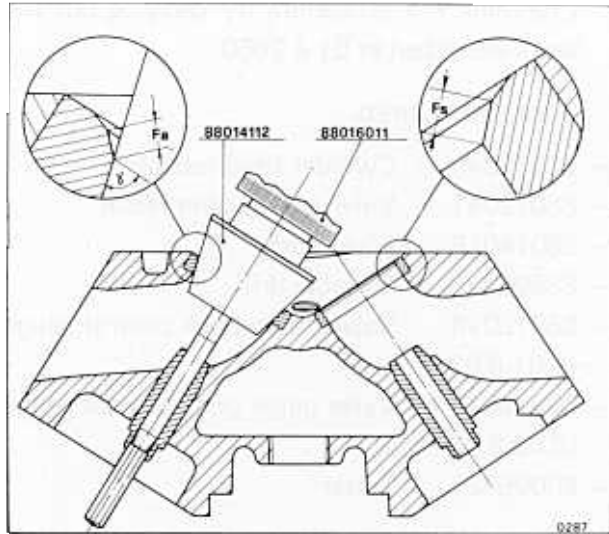

Fig. 01 4/27 - Refacing intake valve seat diameter to reduce Fa width.

- Use a millimetre rule to check that the width of the sealing surface of the intake valve seats Fa conforms to specifications.

If the surface is wider than specified, reduce by machining off the excess lower part with wheel 88014112 (75°).

This operation is not necessary on the exhaust valve seats because their internal diameter is at right angles to the top surface; the specified width for surface Fs can therefore only be obtained with grinding wheel 88014111 (20°).

- Clean the cylinder head thoroughly and dry with compressed air.
- Grind the valves with grinder 88016006.

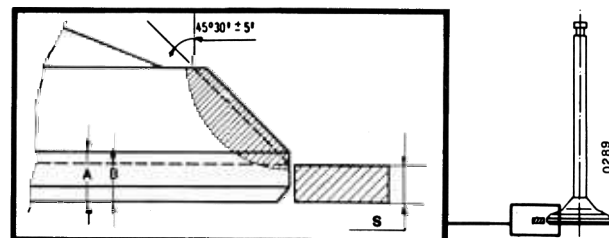

Fig. 01 4/28 - Dimensions needed to check valve head contour thickness.

With the grinding operation completed, rest the valves on a surface plate and use feeler gauge 88095770 to check that the valve head contour area is thicker than the specified

minimum.

Fit the reground valves to their seats and then rest the cylinder head on plate 88012040 in such a way that the valves are held firmly against their seats.

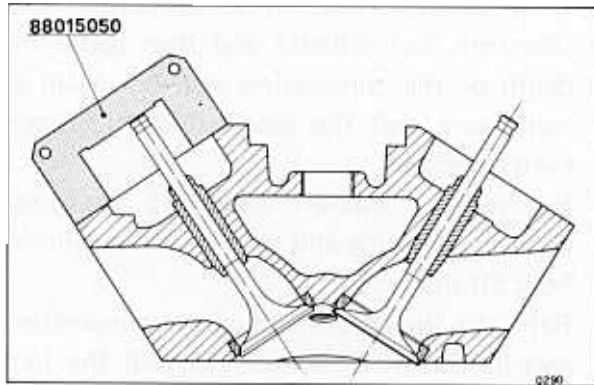

Fig. 01 4/29 - Checking protrusion of valve stems from the cylinder head by means of gauge 88015050.

- Using gauge 88015050, set as in the figure, check that there is a clearance of about 0.1 mm between the stem of each valve and the lower edge of the gauge; if there is not, use grinder 88016006 to remove the material necessary to obtain the specified clearance.
- Wash down the cylinder head and valves with paraffin.

TOOL REQUIRED

- 88016001 - Valve seat grinder kit
- 88014533 - Grinding wheel (45°)
- 88014111 - Grinding wheel (20°)
- 88014112 - Grinding wheel (75°)
- 88012000 - Cylinder head rest plate
- 88015050 - Gauge
- 88016006 - Valve grinder

§ 01 4 3100

REPLACING THE VALVE GUIDES (Including refacing valves and seats)

Carry out the work described at 01 4 2700 and then *proceed as follows*:

- Using a suitable tool, remove the valve guide seals.
- Remove the guides from the cylinder head with remover-installer 88012042 and measure the guides external diameter for classification purposes; when refitting new valve guides, make sure they belong to the same class as those removed.
- Heat the cylinder head in an electric furnace to a temperature of 100°C and install the new guides by means of installer 88012042 and spacer 88012042 A.

Note: The internal diameter of the replacement valve guides supplied have the specified value but in some cases it might be necessary to reface them.

- Allow the cylinder head to cool and then reface the valve guide bores, if necessary, using the reamer 88014097; then use gauges 88015018 and 88015019 to check that the diameters of the bores are in accordance with specifications.
- Grind the valves and seats as described at 01 4 2710.
- Fit new oil seals to the valve guides by means of installer 88012037.
Complete by carrying out the jobs described at 01 4 2700.

TOOLS REQUIRED

- 88012042 - Remover, installer
- 88012042 A - Spacer
- 88014097 - Reamer
- 88015018 - Gauge (8.01-8.02)
- 88015019 - Gauge (8.03-8.04)

§ 01 4 3300

SURFACING THE CYLINDER HEAD

After carrying out the work described at 01 4 2700, *proceed as follows*:

- Remove the thermistor and excess temperature switch from the cylinder head.

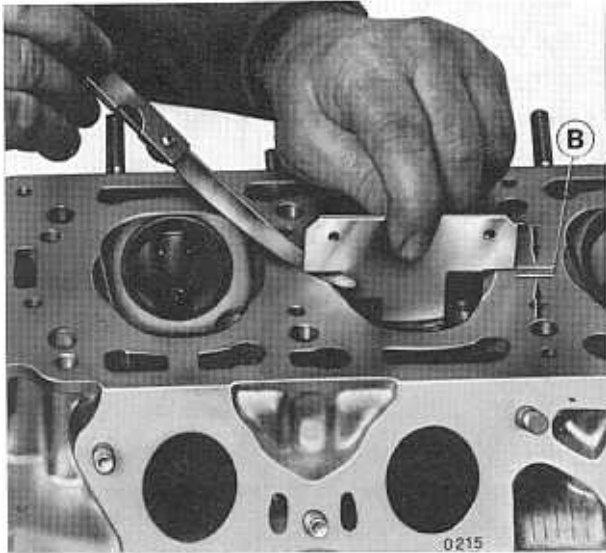

Fig. 01 4/30 - Gauging combustion chamber depth.

- Using gauge 88015038 and feeler gauge 88095770, check the depth of the combustion chamber to make sure that dimension B does not exceed the specified limit.

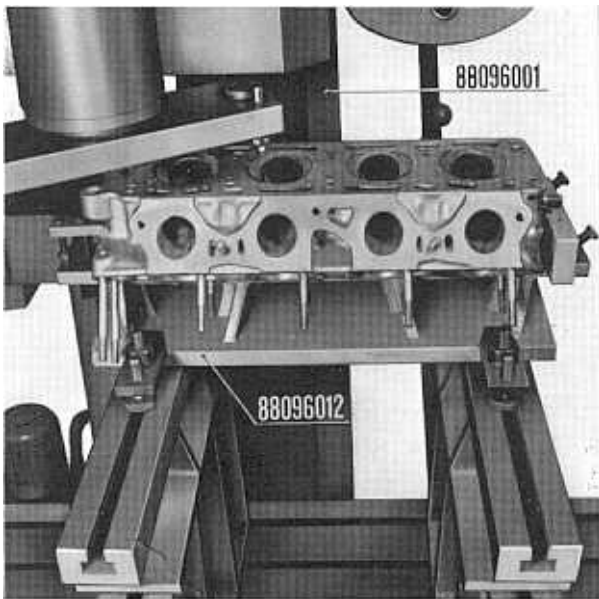

Fig. 01 4/31 - Cylinder head on surfacing machine 88096001.

- Set the cylinder head on support 88096012 and secure with clamps, then fix the support and head to surfacing machine 88096001, making sure that the head surface is in a perfectly horizontal position.

- Surface the cylinder head, removing as little stock as possible.
- When the operation is completed, check that the surface has been machined evenly; should any spots be noted where the tool has failed to remove stock, cut again as required.
- Blow shavings away from the combustion chambers and galleries and then gauge the depth of the combustion chamber again to make sure that the specified limit has not been exceeded.
- Remove the support 88096012 from the surfacing machine and then take the cylinder head off the support.
- Refit the thermistor and excess temperature switch. Complete by carrying out the jobs described at 01 4 2700.

TOOLS REQUIRED

- 88015038 – Combustion chamber depth gauge
- 88096012 – Support
- 88096001 – Surfacing machine

§ 01 4 3400

OVERHAULING A CAMSHAFT HOUSING

Proceed as follows:

- Remove the camshaft drive gear.

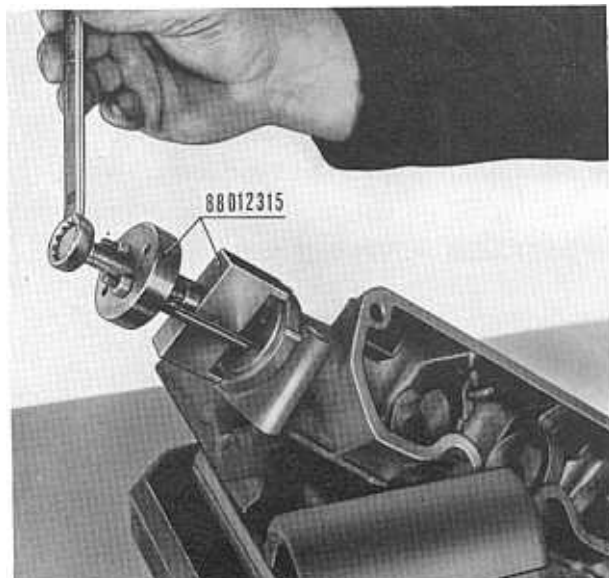

Fig. 01 4/32 - Removing the oil seal by means of tool 88012315.

- Unscrew the securing nuts, remove the rear cover (1) and take out the camshaft.
 - Using tool 88012315, extract the oil seal from its seating.
 - Wash removed components with paraffin and dry with compressed air.
 - Carefully check the camshaft lobes and journals for unusual wear or signs of seizure; if any are noted, replace the camshaft.
 - Check the camshaft housing bearings for deep score marks or excessive wear, and check that clearance between journals and bearings is not excessive.
- Fit the new oil seal using installing tool 88012161.
 - Use engine oil to lubricate the housing bearings and then refit the camshaft and the rear cover after replacing the gasket. Refit the camshaft drive gear.

TOOLS REQUIRED

- 88012315 – Removing tool
- 88012161 – Installing tool

CHAPTER 2

IGNITION

§ 01 2 0300

CHECKING OR TIMING THE IGNITION

Fit the covers 88083051 and *proceed as follows*:

- Remove the spare wheel and heat shield.
- Connect one cable of the timing lamp 88015150 to the ignition coil low voltage outlet and earth the other to the engine.
- Set the ignition key to energize the coil.

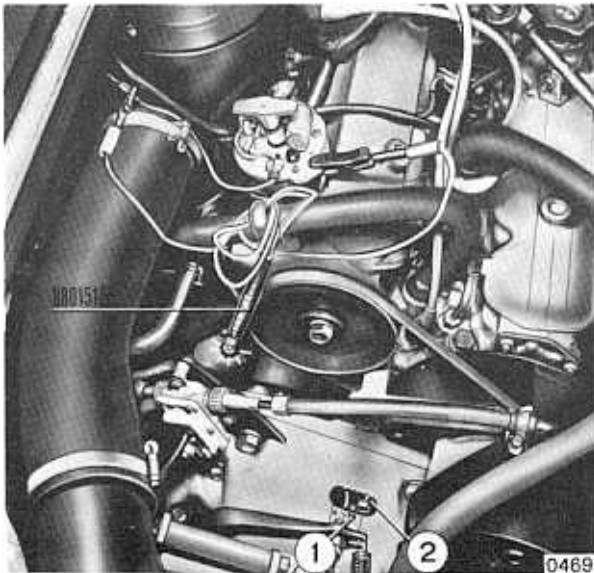

Fig. 01 2/1 Ignition timing references.

Turn the crankshaft in its working direction until the reference (1) on the clutch assembly coincides with the notch (2) on the gearbox.

The instant at which these marks coincide, the distributor contacts should open and the lamp come on.

- If this does not happen, if, in other words, the lamp comes on before the two marks coincide or if the lamp does not come on when the marks coincide, *proceed as follows*:
- Partially slacken the nut securing the distributor clamping bracket, make sure that the reference marks coincide as described, and slowly turn the distributor in a clockwise or anticlockwise direction depending on whether

ignition has to be delayed or advanced, until the required position is reached.

- Tighten the distributor clamping bracket nut.
- Turn the crankshaft a full revolution, make the marks coincide again and check that timing is correct.
- Disconnect the timing lamp and remove the ignition key.

TOOLS REQUIRED

- 88015150 – 12 Volt timing lamp

§ 01 2 0310

CHECKING THE IGNITION STROKE WITH A STROBOSCOPIC LAMP

Fit the covers 8803051 and *proceed as follows*:

- Remove the spare wheel and heat shield.
- Take off the engine compartment lid as described at 15 2 2700.
- Connect up equipment 88075025 as shown in the figure.

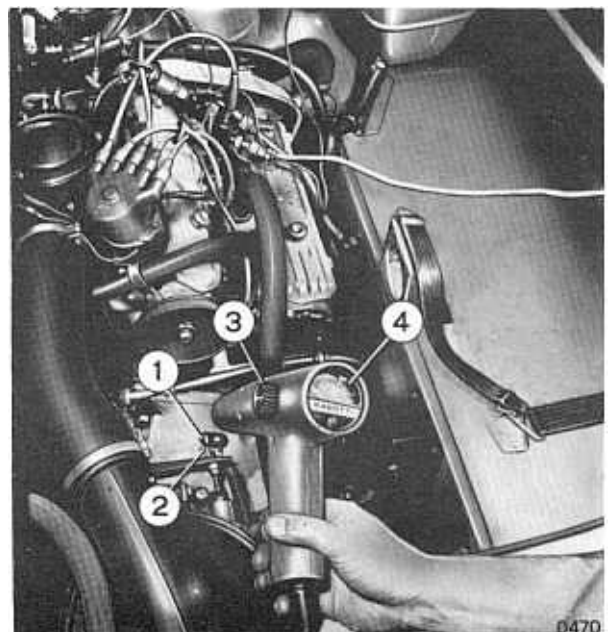

Fig. 01 2/2 - Stroboscopic lamp connections.

Checking fixed advance

- Start the engine and let it idle.
- Check the fixed advance by means of the stroboscopic lamp, having the reference index (1) coincide with the notch (2) on the gearbox. To make the signs coincide, work on the lamp knob (3) and then read the value of the fixed advance on the lamp instrument (4). (If the reading does not coincide with the specification, reset the timing as described at 01 2 0300).

Checking automatic advance

- Carry out the same operation at varying revs, noting instrument (4) readings (degrees of advance). If the readings do not coincide with specifications, overhaul the distributor as described at 01 4 0300).

§ 01 2 0400

REMOVING AND REFITTING IGNITION DISTRIBUTOR AND TIMING THE IGNITION

Fit the covers 88083051 and *proceed as follows:*

Removing

Fig. 01 2/3 - References on gearbox.

Turn the crankshaft until the reference (1) on the clutch assembly coincides with the mark (2) on the gearbox.

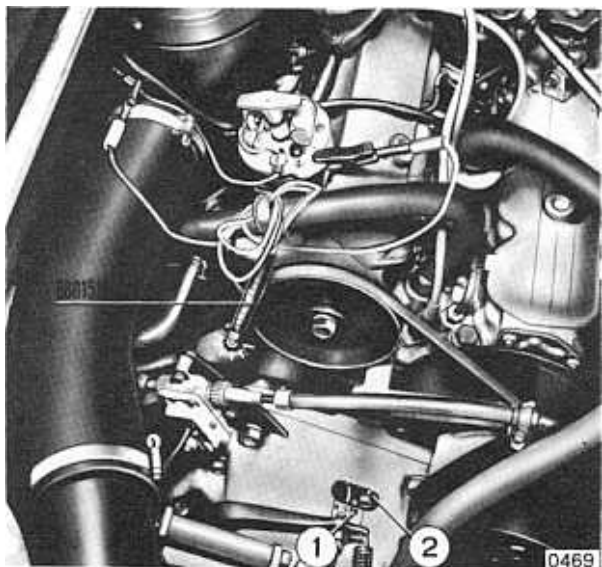
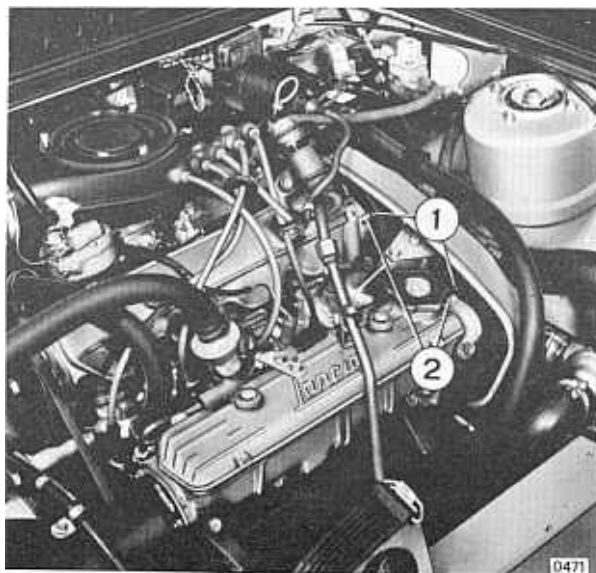

Fig. 01 2/4 - Setting of timing gears during the ignition phase.

- With the crankshaft in this position, the holes (1) in the gears should more or less correspond to references (2) on the supports. At this position, cylinder no. four will be at the expansion stroke.
- Disconnect the cables from the plugs and the high voltage cable from the ignition distributor cap.
- Remove the distributor cap securing screws and the cap itself complete with cables.
- Disconnect the distributor low voltage input cable.
- Unfasten the nut securing the distributor clamping bracket, withdraw the distributor from its seating (making sure beforehand that the brush is set for cylinder four ignition).

Refitting

- Set the distributor brush for cylinder four ignition.
- Fit the distributor into its seat and, with the brush in the specified position engage the gear in the camshaft.
- Fit the distributor bracket without tightening the securing nut.
- Time the distributor as described at 01 2 0300.

ANTIPOLLUTION

§ 01 2 0690

REMOVING AND REFITTING GAS FLUID VAPOR SEPARATORS

Fit the covers 88083051 and *proceed as follows:*

- Remove the spare wheel and heat shield.

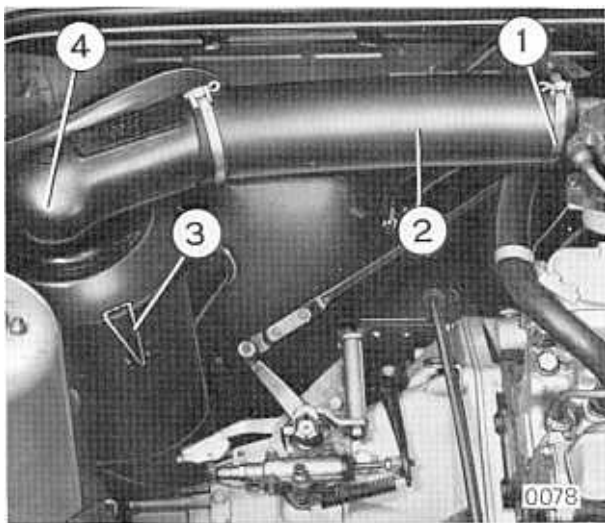

Fig. 01 2/5 - Air cleaner

- Slacken the clamp (1), withdraw the pipe (2), unclip the retainers (3) and take off the lid (4).

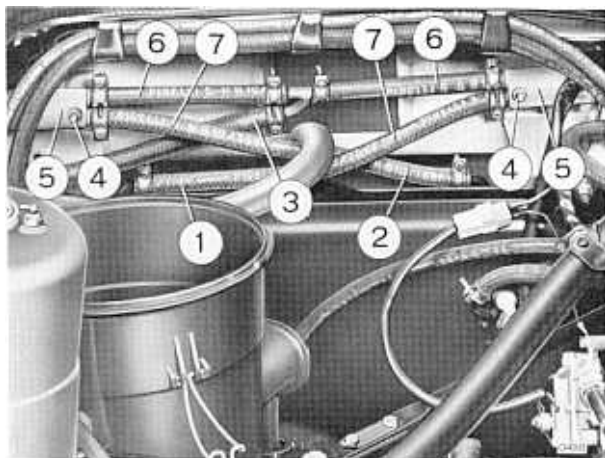

Fig. 01 2/6 - Gas fluid vapor separators

- Slacken the clamps and withdraw the pipes (1, 2 and 3).
- Unscrew the nuts (4) and take off the

separators (5).

- Then slacken the clamps and withdraw the pipes (6 and 7) from the separators (5).
- Refit in the reverse order.

§ 01 2 0700

REMOVING AND REFITTING GAS TANK VENTILATION VALVE

Fit the covers 88093051 and *proceed as follows:*

- Remove the spare wheel and heat shield.

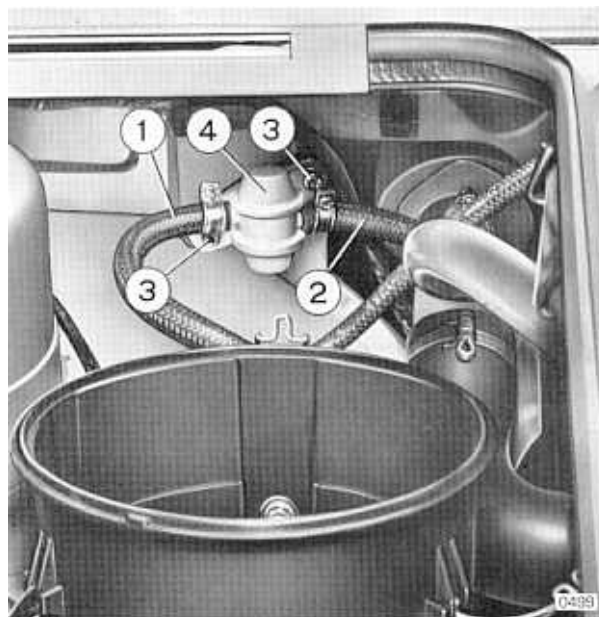

Fig. 01 2/7 - Air cleaner

- Slacken the clamp (1), withdraw the pipe (2), unclip the retainers (3) and take off the lid (4).
- Slacken the clamps and withdraw the pipes (1 and 2) then unscrew the bolts (3) and remove the valve (4).
- Refit in the reverse order.

§ 01 2 0710

REMOVING AND REFITTING GAS VAPOR
CLEANER

Fit the covers 88083051 and *proceed as follows*:

- Remove the spare wheel and heat shield.

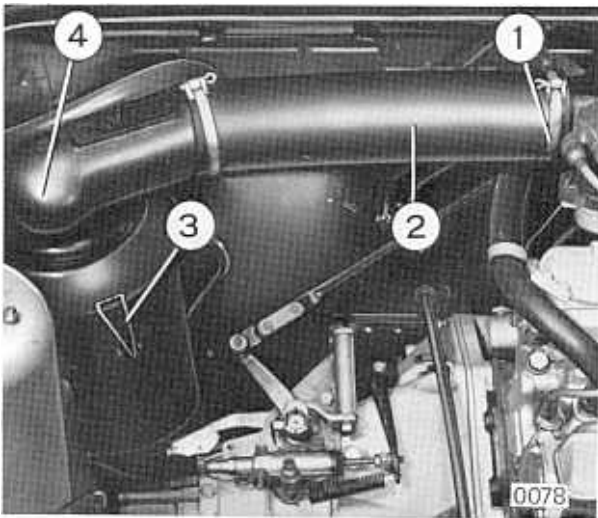

Fig. 01 2/8 - Air cleaner.

Unclip the retainers (3), and remove the lid (4) and the complete air cleaner body.

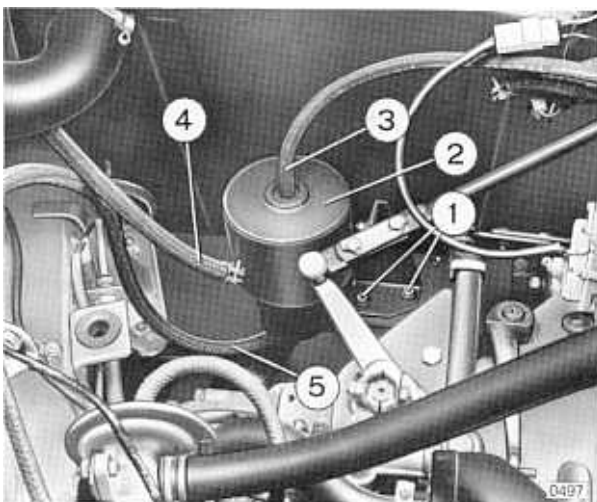

Fig. 01 2/9 - Gas vapor cleaner

- Unfasten the nuts (1) and remove the cleaner (2), then withdraw the pipes (3, 4 and 5).
- At the bench, take the gas vapor cleaner off the clamping bracket.
- Refit in the reverse order.

§ 01 2 0720

REMOVING AND REFITTING THE AIR PUMP

Fit the covers 88083051 and *proceed as follows*:

Removing

- Remove the spare wheel and heat shield.

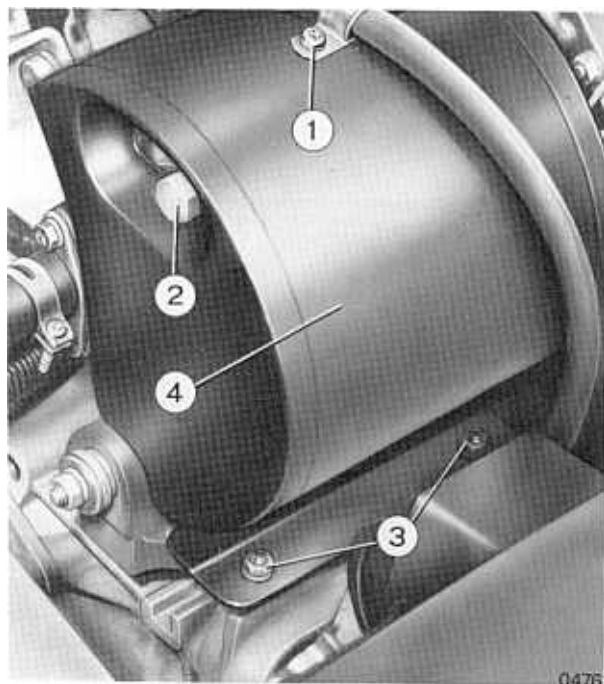

Fig. 01 2/10 - Removing air pump guard

Unscrew the bolts (1 and 2) and the nuts (3) and remove the guard (4).

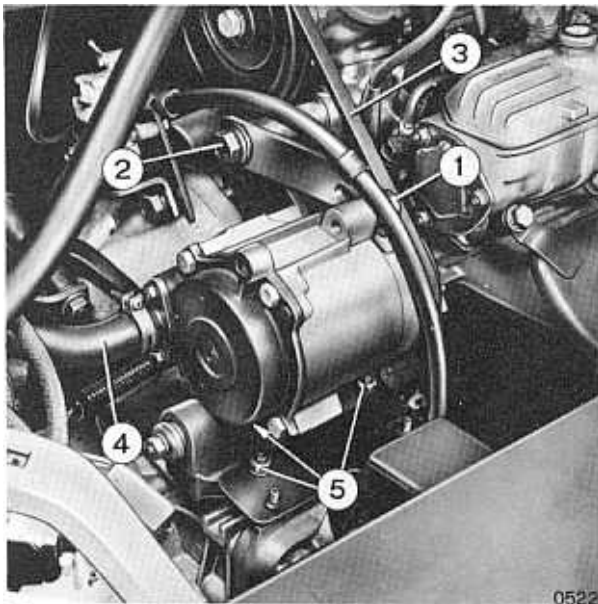

Fig. 01 2/11 - Removing air pump

- Unscrew the nut (1) and the bolt (2) and remove the belt (3).
- Withdraw the pipe (4), unscrew the nuts (5) and remove the air pump.

Refitting

- Refit the air pump and fit the belt on the pulley.

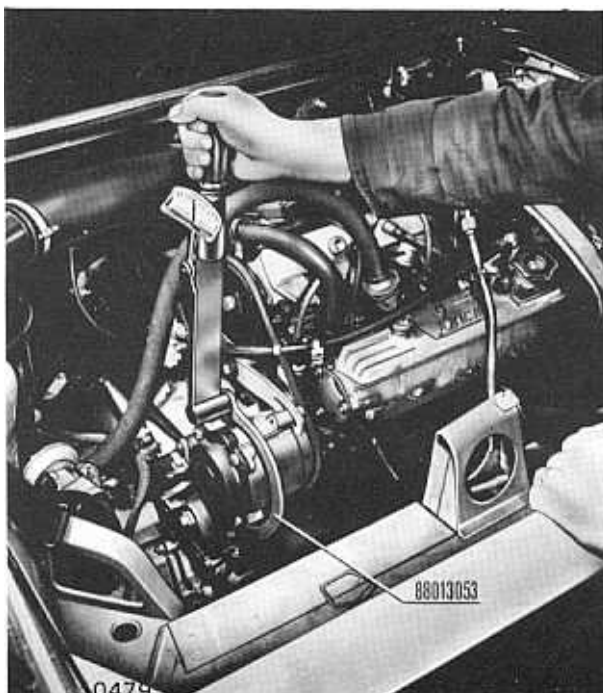

Fig. 01 2/12 - Stretching the air pump belt.

- Apply tool 88013053 and torque wrench 88091134 set to the specified torque, stretch the belt and tighten the nuts (1).
- Refit the remaining parts in the reverse order.

TOOLS REQUIRED

- 88013053 – Tool
- 88091134 – Torque wrench.

§ 01 2 0730

REMOVING AND REFITTING DIVERTER VALVE, THREE-WAY VALVE, AND THREE-WAY ELECTROVALVE

Fit the covers 88083051 and *proceed as follows:*

- Remove the spare wheel and heat shield.

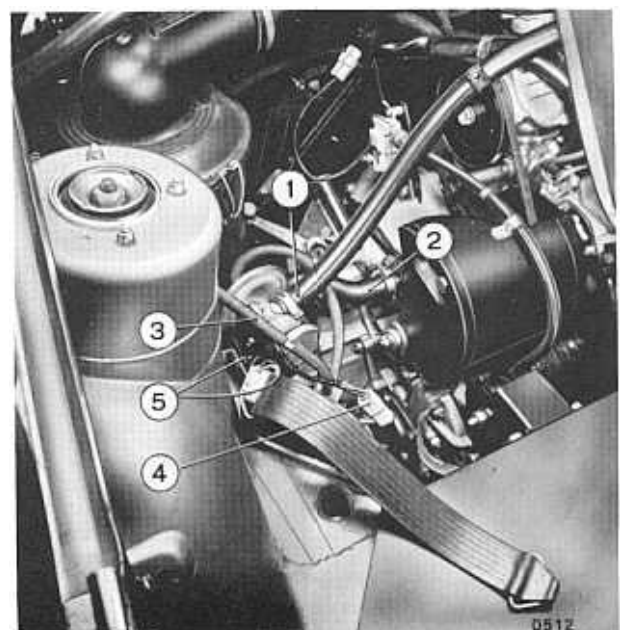

Fig. 01 2/13 - Removing valve assembly

- Detach the pipes (1, 2 and 3), disconnect the bushing (4), unscrew the nuts (5) and remove the valve assembly.

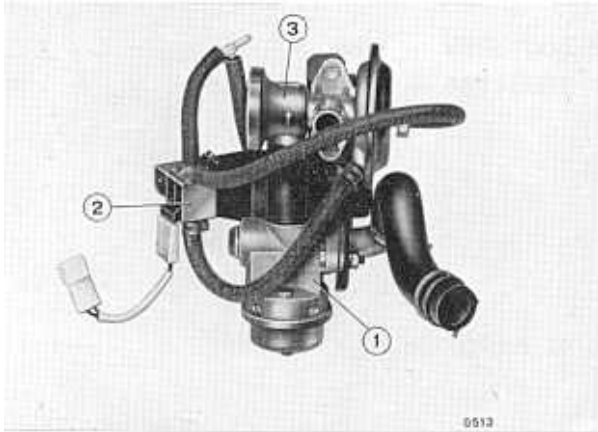

Fig. 01 2/14 - Valve assembly.

- At the bench remove the diverter valve (1), the three-way valve (2) and the three-way electrovalve (3).
- Replace any parts found to be worn and then refit the valves, connecting the flexible piping as shown in the figure; complete refitting in the reverse order to removal.

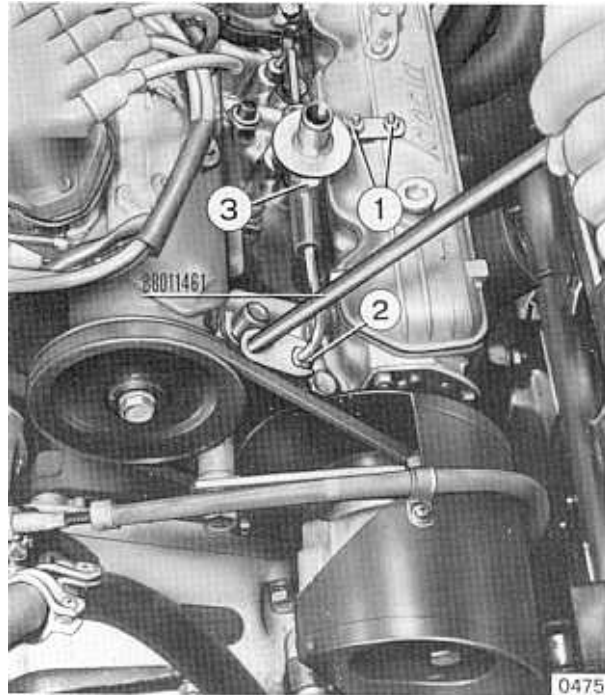

Fig. 01 2/15 - Removing check valves and exhaust pipe air hose.

- Unfasten the nuts (1), unscrew the couplings (2) by means of wrench 88011461 and then disconnect the hose (3).
- At the bench, remove the check valve from the exhaust pipe air hose.
- Refit in the reverse order to removal.

§ 01 2 0740

REMOVING AND REFITTING CHECK VALVE
AND EXHAUST PIPE AIR HOSE

Fit the covers 88083051 and *proceed as follows*:

- Remove the spare wheel and heat shield.
- Withdraw the air hose from the check valve.
- Remove the spark plugs.

§ 01 2 0780

REMOVING AND REFITTING EXHAUST GAS
RECIRCULATION PIPES AND VALVE (E.G.R.)

Fit the covers 88083051 and *proceed as follows*:

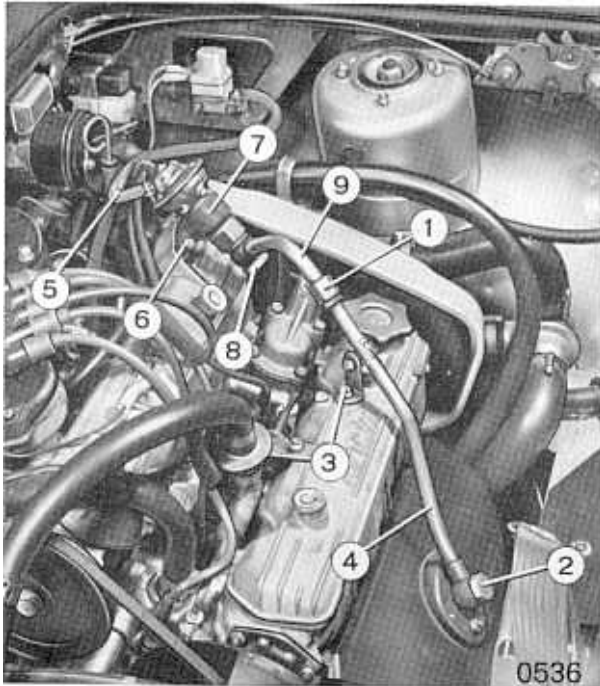

Fig. 01 2/16 - Exhaust gas recirculation valve and pipes

- Unscrew the nut (1) and bolt (2) and then unscrew nut (3) and disconnect the pipe (4).
 - Withdraw the pipe (5), unfasten the bolts (6) and remove the complete valve (7).
- At the bench, remove the bolt (8), and separate the pipe (9) from the valve (7).
- Replace any worn parts and refit in the reverse order to removal.

§ 01 2 0790

REMOVING AND REFITTING VACUUM THERMOSTAT CONTROLLING EXHAUST GAS RECIRCULATION VALVE (E.G.R.)

Fit the covers 88083051 and *proceed as follows*:

- Remove the carburettor as described at 01 2 3200 of the following variant.
- Withdraw the pipes (1 and 2) and remove the valve (3).
- Refit in reverse order to removal.

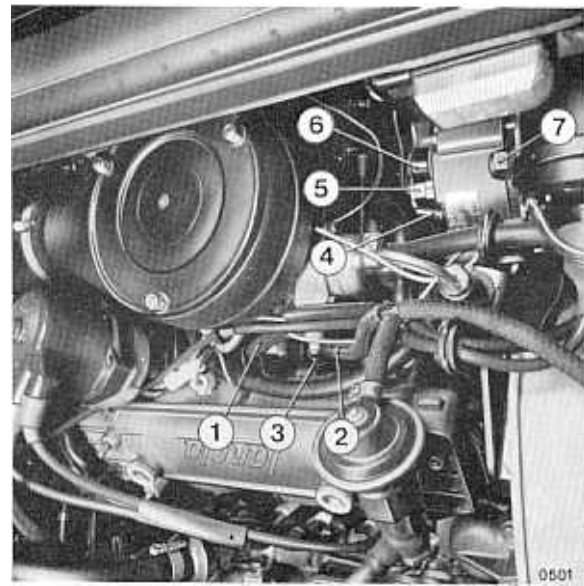

Fig. 01 2/17 - Vacuum thermostat.

§ 01 2 0800

REMOVING AND REFITTING ELECTROVALVE FOR CUTTING OUT EXHAUST GAS RECIRCULATION VALVE (E.G.R.)

Fit the covers 88083051 and *proceed as follows*:

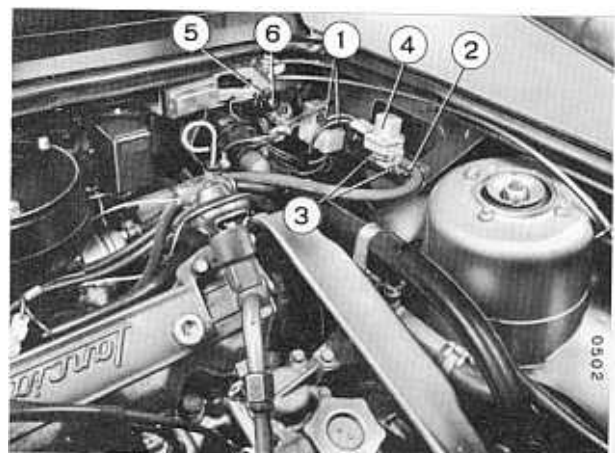

Fig. 01 2/18 - E.G.R. cut-out valve.

- Withdraw the cables (1) and pipe (2), unfasten the nut (3) and remove the valve (4).
- Refit in the reverse order.

§ 01 2 0810

REMOVING AND REFITTING A PUSH-BUTTON
SWITCH ON THE GEARBOX

Fit the covers 88083051 and *proceed as follows*:

- Remove the spare wheel and the heat shield.

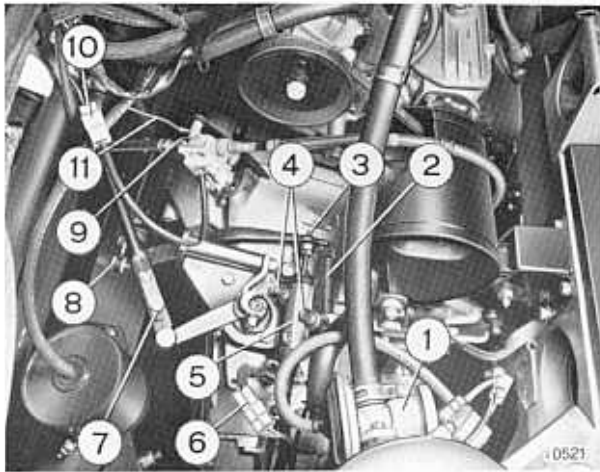

Fig. 01 2/19 - Removing push-button switch on gearbox

- Unhook the spring (2), withdraw the split pin (3), unfasten the bolts (4) and remove the cylinder (5).
- Withdraw the electric cables and remove the push-button switch requiring repair.
- Refit in the reverse order.

§ 01 2 0830

REMOVING AND REFITTING FAST IDLER
HAND CONTROL SWITCH

Proceed as follows:

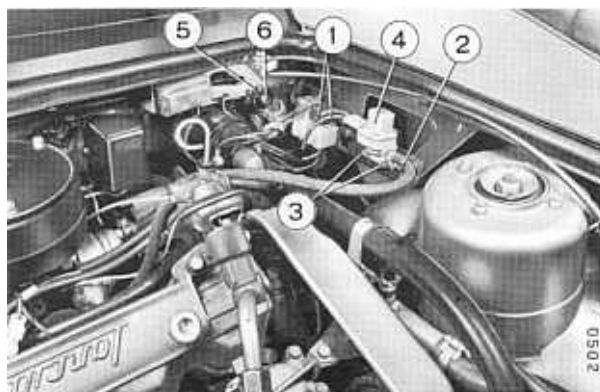

Fig. 01 2/20 - Fast idler hand control switch

- Unfasten the ring nut (5) and remove the switch (6), then withdraw the connection cables.
- Refit in the reverse order.

§ 01 2 0840

REMOVING AND REFITTING FAST IDLER
CONTROL ELECTROVALVE

Fit the covers 88083051 and *proceed as follows*:

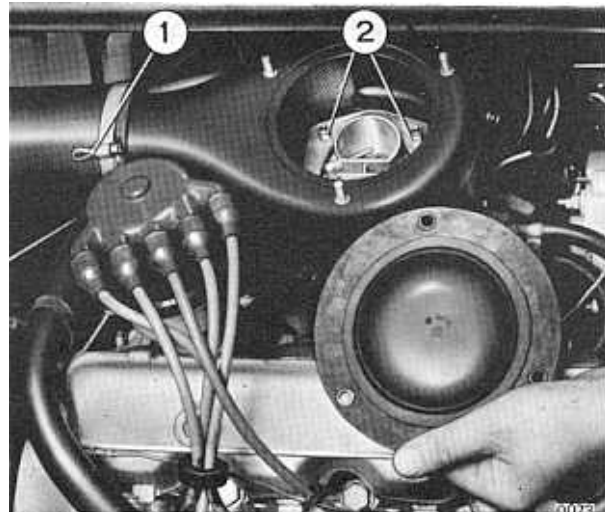

Fig. 01 2/21 - Carburettor air intake

- Slacken the clamp (1) and remove the pipe.
- Take off the air intake cover, remove the nuts (2), withdraw the oil vapor breather pipes and remove the air intake (3).

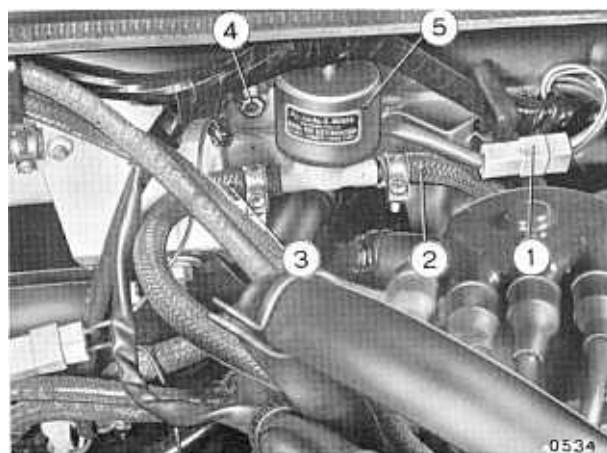

Fig. 01 2/22 - Fast idler control electrovalve

- Disconnect the bushing (1), withdraw the pipes (2 and 3), unscrew the nut (4) and remove the electrovalve (5).
- Refit in the reverse order to removal.

§ 01 2 0850

REPLACEMENT OF FAST IDLER DIAPHRAGM BODY

Fit the covers 88083051 and *proceed as follows:*

With ref. to Fig. 01 2/21

Slacken the clamp (1) and remove the pipe.

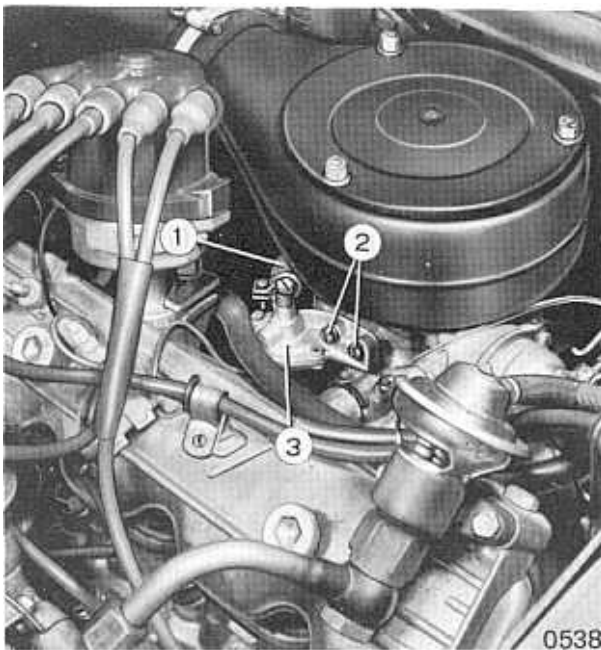

Fig. 01 2/23 - Carburettor.

- Take off the air intake cover, remove the nuts (2), withdraw the oil vapor breather pipes and remove the air intake (3).
- Withdraw the pipe (1), unfasten the bolts(2) and take off the fast idler device (3).
- Refit the fast idler and the remaining parts removed.
- When this operation has been completed, regulate the fast idler as described at 01 2 0860.

§ 01 2 0860

REGULATING FAST IDLER

Fit the covers 88083051 and *proceed as follows:*

Note: The fast idler should be regulated when the engine is hot, turning and with the air cleaner fitted.

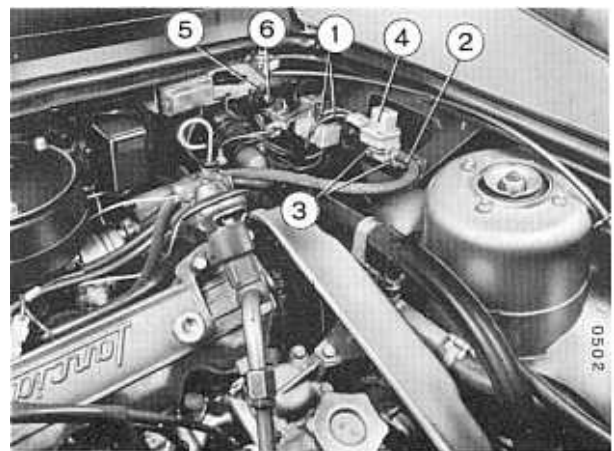

Fig. 01 2/24 - Fast idler hand control.

- Press the button (6) to connect fast idler.

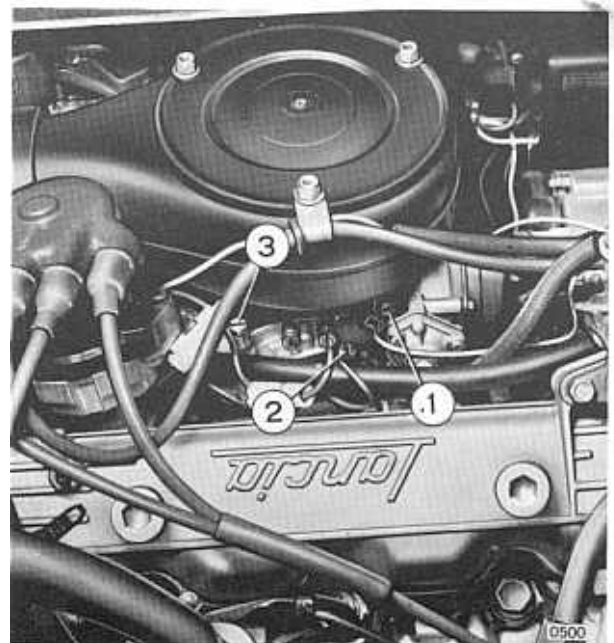

Fig. 01 2/25 - Regulating fast idler.

Work simultaneously on the bolt (3) until fast idling revs conforming to what is shown on the plate of the figure below are obtained.

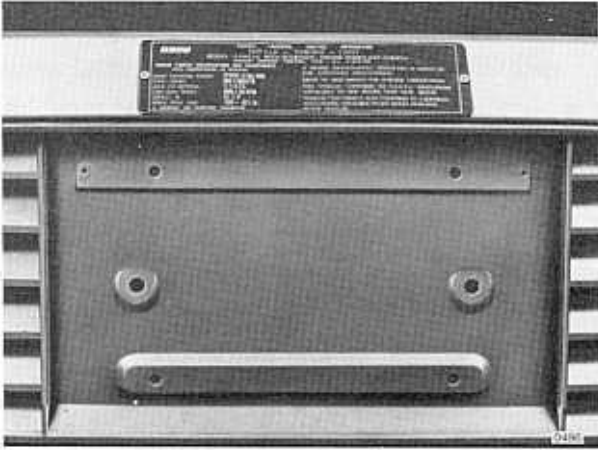

Fig. 01 2/ 26 - Anti-pollution data plates.

§ 01 2 0870

REMOVING AND REFITTING EXHAUST GAS RECIRCULATION (E.G.R.) SYSTEM ALARM

Fit the covers 88083051 and *proceed as follows:*

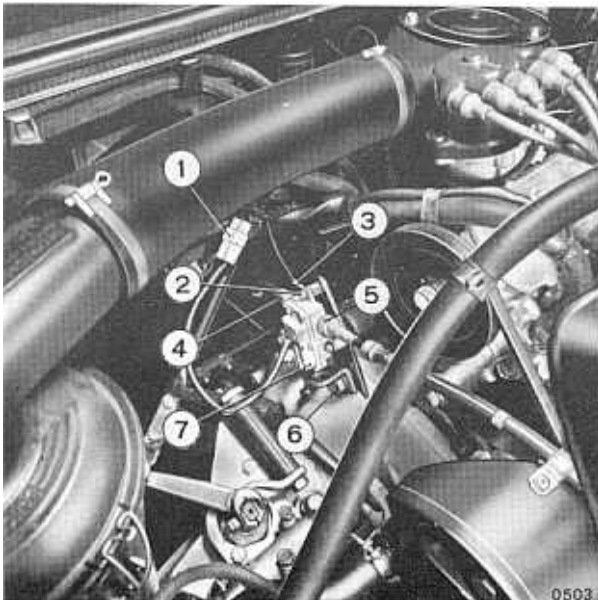

Fig. 01 2/27 - EGR system alarm

- Disconnect the bushing (1), remove the bolt (2) and take off the cable (3).
- Disconnect the mile-counter sheath (4 and 5) then unfasten the bolt (6) and remove the alarm (7) complete with bracket.
- Refit in reverse order to removal and tighten the bolt (6) to the specified torque loading and put back the ring nut (5) seal.

§ 01 2 0880

REMOVING AND REFITTING ACCESSORY GEARBOX

Fit covers 88083056 and 88083058 and *proceed as follows:*

Removing

- Open the glove compartment and remove the air panel.
- Remove the bolts securing the top of the glove compartment, withdraw the bayonet fitting and lighting earth cable, and then remove the compartment.

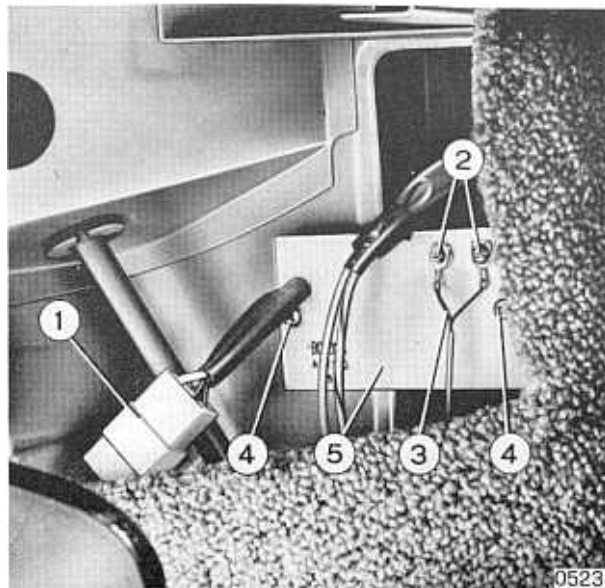

Fig. 01 2/28 - Accessory gearbox.

- Disconnect the bushing (1), slacken the bolts (2) and withdraw the cables (3).
- Remove the bolts (4) and take off the accessory gearbox (5).

Refitting

- Refit in the reverse order to removal.

§ 01 2 0890

REMOVAL AND REFITTING OF THE ELECTRONIC SPEEDOMETER

Fit covers 88083051 and *proceed as follows:*

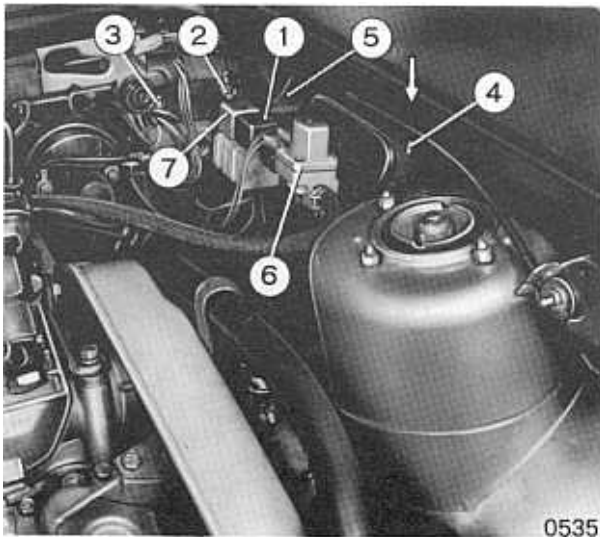

Fig. 01 2/29 - Speedometer mounting bracket

- Remove the remote control switches (1 and 7).
- Unscrew the nuts (2 and 3) and the bolt (4). Take off the bracket (5), complete with the solenoid (6).

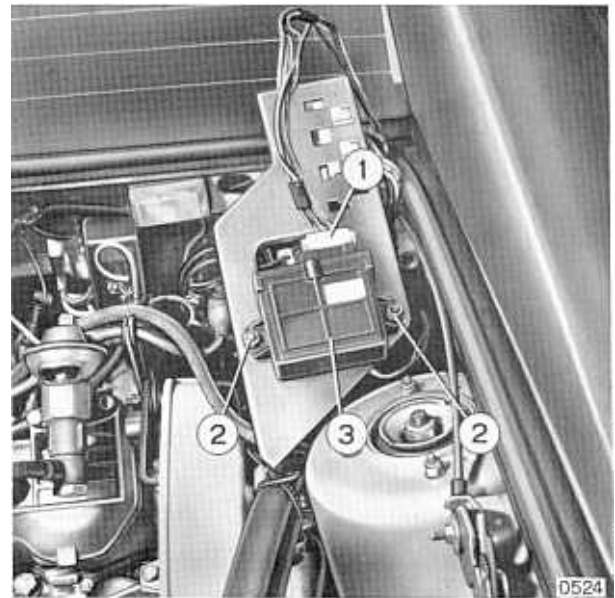

Fig. 01 2/30 - Electronic speedometer

- Disconnect the block (1), unscrew the nuts (2) and remove the device (3).
- Refit in the reverse order.

FEED

§ 01 2 1100

REMOVING AND REFITTING FUEL TANK COMPLETE WITH LEVEL GAUGE CONTROL

Drive the car over the pit, fit the covers 88083051 and *proceed as follows*:

Removing

Remove the air cleaner body assembly as described at 01 2 1700.

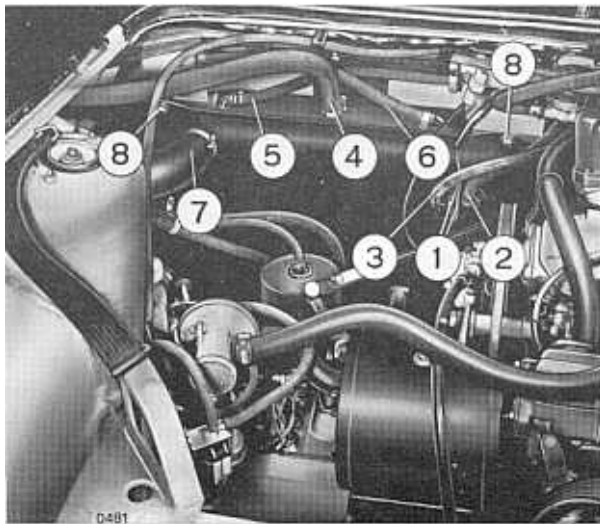

Fig. 01 2/31 - Removing the fuel tank.

- Withdraw the wires (1) from the fuel gauge transmitter.
- Withdraw hoses (2, 3, 4, 5 and 6) and coupling (7) from the fuel tank.
- Working below the car, remove the air shroud and then take off the tank, simultaneously unfastening bolts (8) shown in the previous figure and the lower securing bolt (two mechanics are needed for this operation).
- Remove the fuel level gauge transmitter from the tank.

Refitting

- When refitting, do not tighten the lower securing bolt before fitting bolts (8) of fig. 01 2/33; complete operations by refitting in the reverse order to removal.

§ 01 2 2200

CLEANING THE CARBURETTOR, BLOW-THROUGH OF THE JETS AND ADJUSTMENT OF THE SLOW-RUNNING JET

Fit covers 88083051 and *proceed as follows*:

- Remove the carburettor cover as described at 01 2 2250.

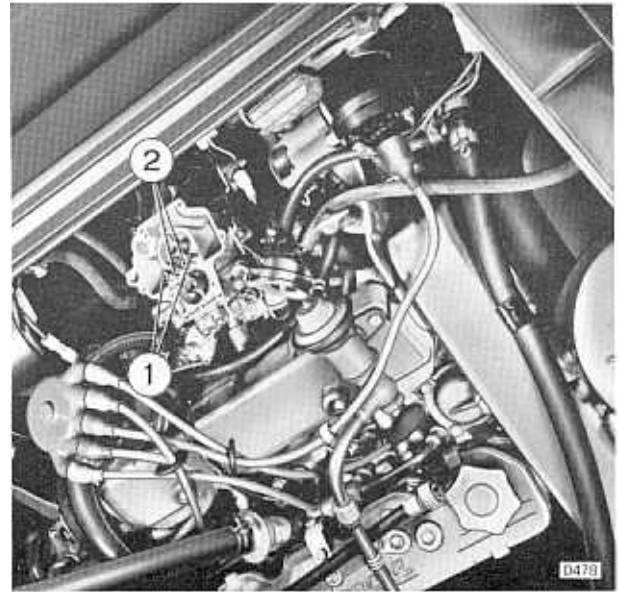

Fig. 01 2/32 - Weber 32 DATRA 9/100 carburettor

- Unscrew the emulsifying tubes (2), complete with the slow-running jets (1) on their bottom part, from the carburettor body.
- Blow the jets through with compressed air and check that they are not so worn as to require renewal. Check that the specifications stamped on the jets are correct.
- Clean the filter. This is mounted in the float chamber cover.
- Clean the float chamber.
- Check that the gasket between the cover and the body of the carburettor is not damaged and renew if necessary.
- Refit the jets and emulsifiers.
- Refit the float chamber cover as described at 01 2 2250.

§ 01 2 2250

REMOVING AND REFITTING THE
CARBURETTOR FLOAT CHAMBER COVER
(Weber carburettor)

Fit covers 88083051 and *proceed as follows*.

Removal

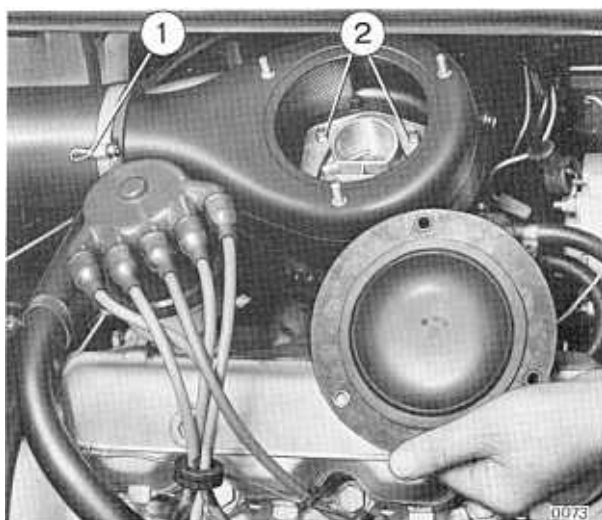

Fig. 01 2/33 - Carburettor air intake

- Slacken clamp (1) and slide off the pipe.
- Remove the air intake cover, unscrew the nuts (2), slide off the oil vapour breather pipes and remove the air intake.

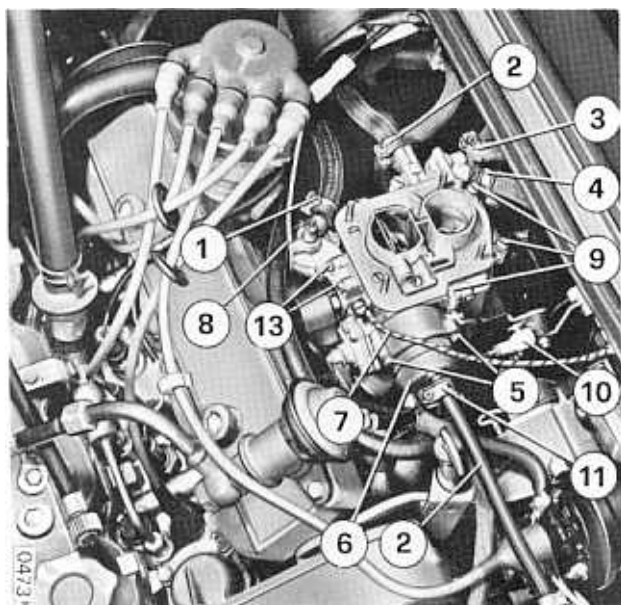

Fig. 01 2/34 - Removal of flexible hoses.

Take off hoses (2, 3, 4) and leads (7, 8).

- Unscrew bolts (9) and remove the carburettor cover. Unscrew bolts (5) and take choke cover (6) off the carburettor cover. The fuel level check is described at § 16 4 1150.

Refitting

- Refit the choke to the carburettor cover as follows:

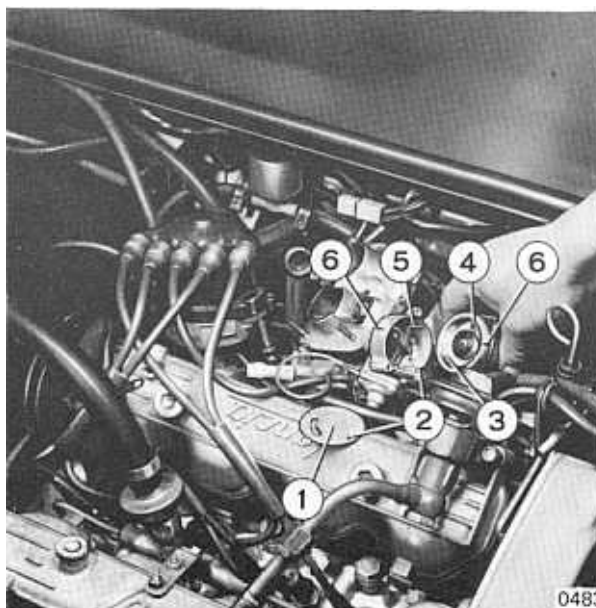

Fig. 01 2/35 Rich mixture control mechanism

- Fit gasket (1) so that the reference marks (2) coincide, then mount the coil housing (3). Fit the bimetallic coil (4) into the yoke (5) of the rich mixture control, then turn the housing anticlockwise until the reference marks (6) coincide.
- Refit the remaining components in the reverse order.
- On completion, set the slow-running mechanism as described at § 01 2 2300.

§ 01 2 2300

SETTING OF THE SLOW-RUNNING
MECHANISM

Fit covers 88083051 and *proceed as follows*:

Note – This operation must be done with the

engine warmed-up and running, and with the air filter mounted.

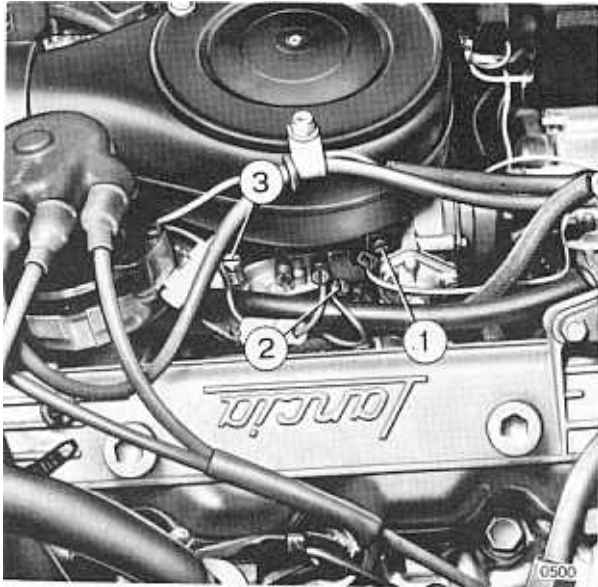

Fig. 01 2/36 - Setting the slow-running mechanism

First set the primary choke throttle by means of bolt (1) until the engine runs steadily. Then set bolt (2) to obtain a mixture at which the engine turns fastest and steadiest at that throttle setting. Lastly, set bolt (1) to get the engine setting shown on the data plate in the photo below.

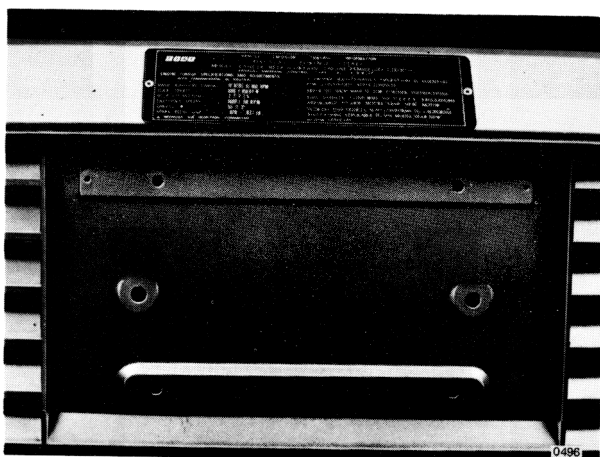

Fig. 01 2/37 - Anti-pollution data plate

§ 01 2 3200

REMOVING AND REFITTING CARBURETTOR WITH ADJUSTMENT OF ENGINE IDLE RUNNING MECHANISM

Fit the covers 88083051 and *proceed as follows:*

Removing

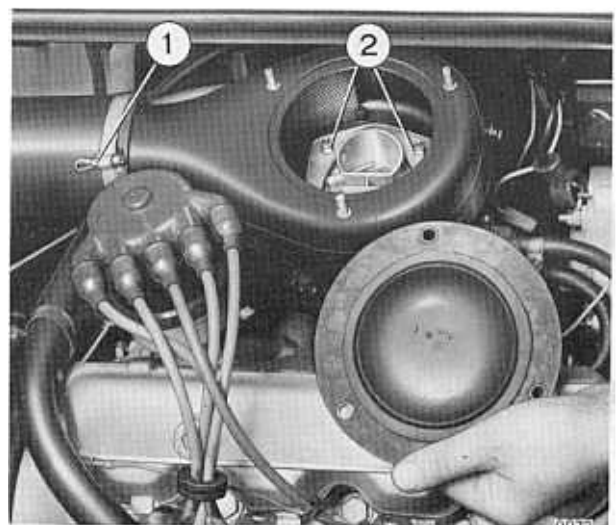

Fig. 01 2/38 - Carburettor air intake

- Slacken the clamp (1) and withdraw the hose.
- Remove the air intake cover, unfasten the nuts (2) and withdraw the oil vapor breather pipes.

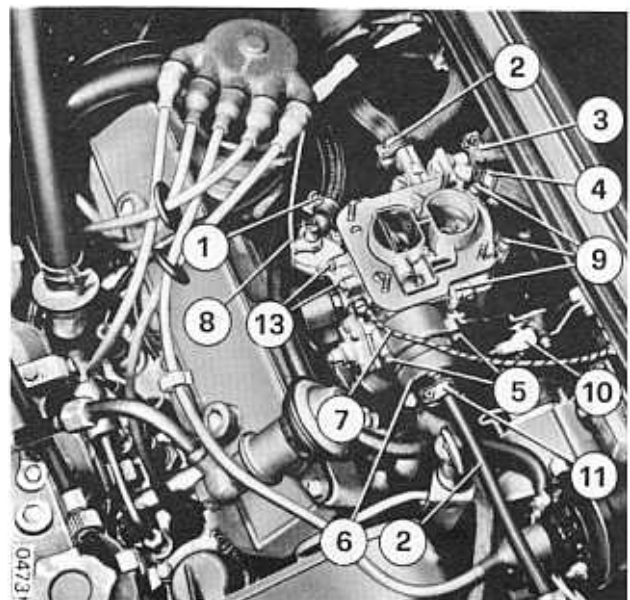

Fig. 01 2/39 - Carburettor

- Fit the gasket (1), making sure that the references (2) coincide. Then apply the spiral body (3), making the bimetallic spiral (4) engage with the rich mixture control fork (5), then turn the spiral body in an anticlockwise direction until the references (6) coincide.
- Complete by refitting the remaining parts in the reverse order.
- When the refitting operation is completed, adjust the idle running mechanism as described at 01 2 2300.
- Remove cables (7 and (8).
- Remove pipes (1, 2, 3 and 4).
- Undo bolts (13) and take off the fast idling device.
- Remove the accelerator control (10) from the carburettor.
- Unscrew the nuts holding the carburettor to the induction manifold and remove the manifold.
- Undo bolts (5) and remove the housing (6) from the carburettor, then lay the housing to the side along with the connected piping and recover the carburettor.

Refitting

- Refit the carburettor on the induction manifold.

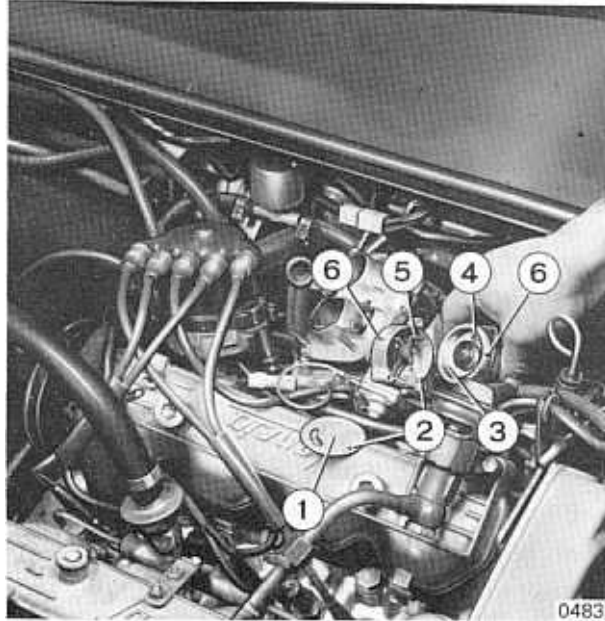

Fig. 01 2/40 - Enrichment device.

EXHAUST

§ 01 2 4300

REMOVING AND REFITTING THE EXHAUST PIPE ASSEMBLY

Removal

- Stand the vehicle over the pit and *proceed as follows*:

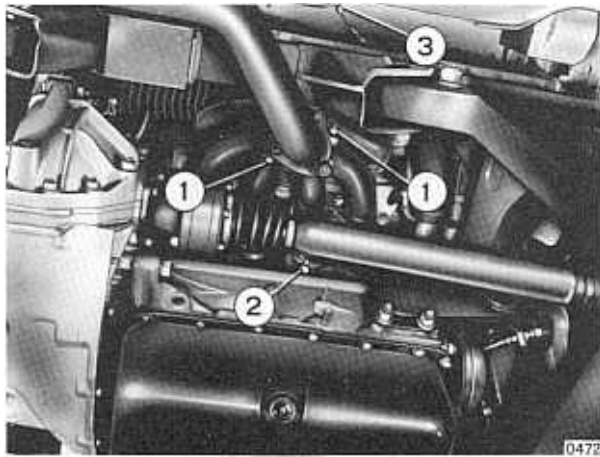

Fig. 01 2/41 - Removal of exhaust pipe from manifold

- Take off the exhaust pipe heat shield.
- Unscrew the pins (1) and remove the exhaust pipe from the manifold. Then take off the thermocouple (2).

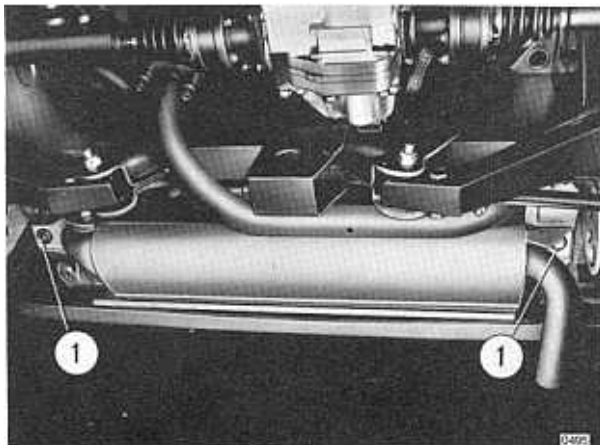

Fig. 01 2/42 - Removal of exhaust pipe assembly.

- Unscrew bolts (1) and take off the complete assembly.

At the bench

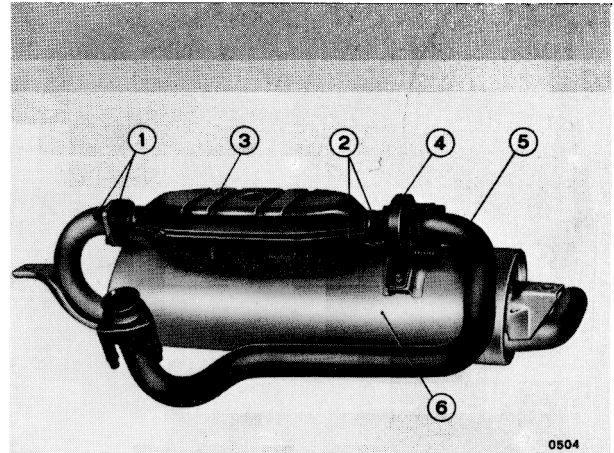

Fig. 01 2/43 - Complete exhaust pipe assembly.

- Unscrew bolts (1, 2) and detach the tail silencer (3) from the intermediate pipe (4), the front pipe (5) and the main silencer (6).

Refitting

- Refit in the reverse order.

CYLINDER HEAD

§ 01 2 7700

REMOVING AND REFITTING CYLINDER HEAD
(INCLUDING CHECKING VALVE TAPPET CLEARANCE, EXCLUDING SETTING)

Drive the car over the pit, fit the covers 88083051, drain the coolant as described at 01 2 4650 and *proceed as follows:*

Removing

- Disconnect the positive battery cable.
- Working below the car, remove the exhaust pipe heat shield.

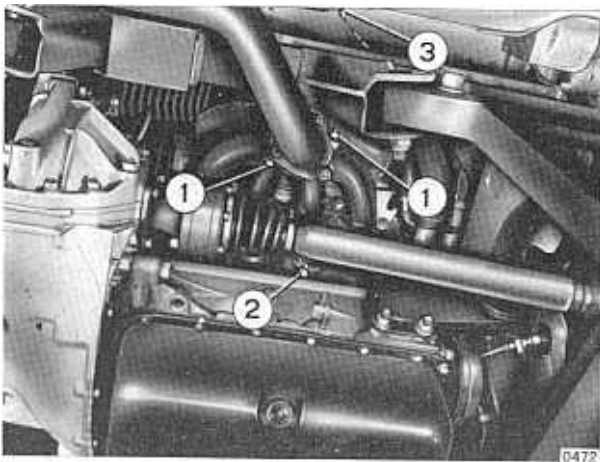

Fig. 01 2/44 - Removing the exhaust pipe from the manifold.

Unfasten the pins (1) and remove the exhaust pipe from the manifold.

Working in the engine compartment, remove the spare wheel and heat shield.

Slacken the clamps (1, 2, 3, 4, 5 and 6) then remove the coupling complete with sleeves and thermostat.

Note: A certain amount of coolant might come out of the thermostat union; to avoid this inconvenience, the remaining fluid can be drained beforehand through the drain screw

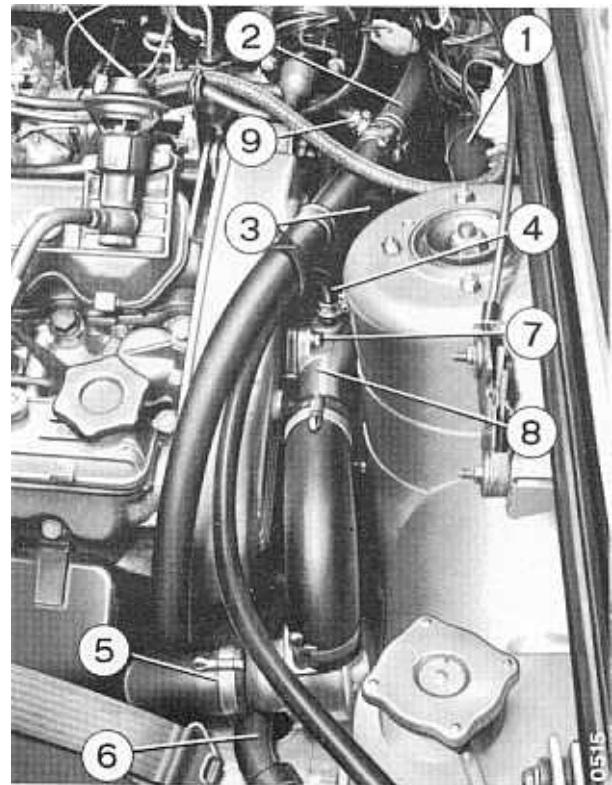

Fig. 01 2/45 - Coolant pipes.

(2) shown in fig. 01 2/44.

Unscrew the nut securing the upper alternator clamping bracket and withdraw the coolant pump control belt and alternator.

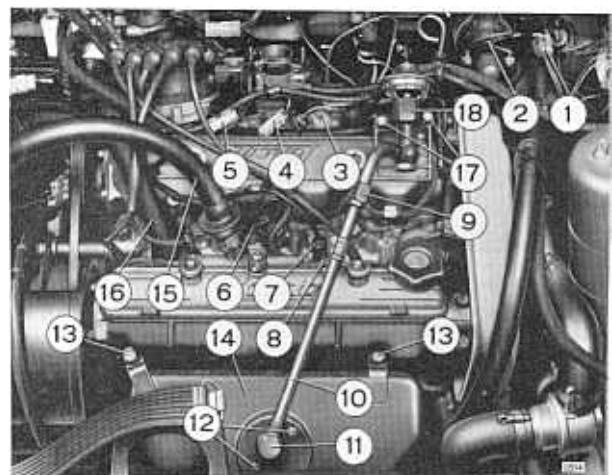

Fig. 01 2/46 - Upper part of engine.

- Remove the nuts (8) and the bolts (11) and (17), then remove the valve (18) together with the hose.
- Unfasten the bolts (13) and the nuts (12) and remove the shield (14).

- Disconnect the electric cables (2, 3, 4, 5, 6 and 7) and hoses (15 and 16).
- Disconnect the plug cables and plugs, then disconnect the high voltage cable from the coil ignition.

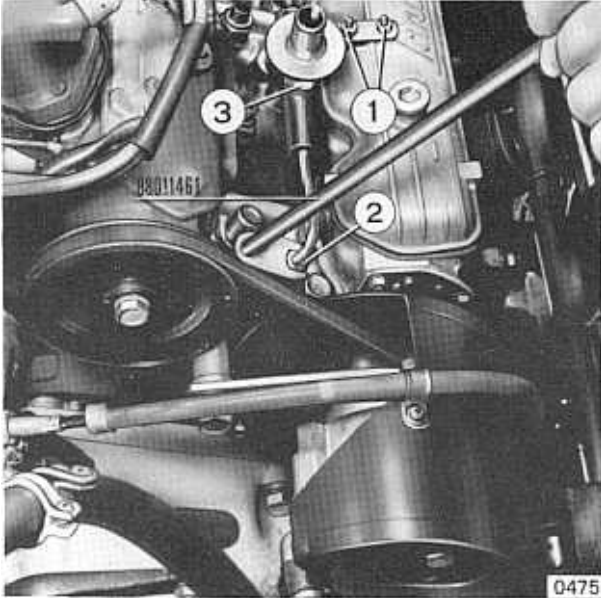

Fig. 01 2/47 - Removing air-to-exhaust manifold pipe with tool.

- Remove the nuts (1), unfasten the couplings (2) using wrench 88011461 and then take off the pipe (3).

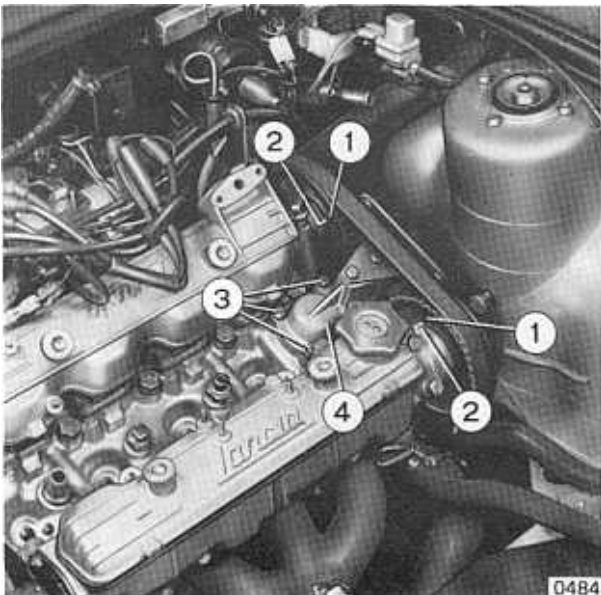

Fig. 01 2/48 - Timing.

Turn the drive shaft in normal rotation direction (clockwise) until the holes (1) are aligned with the references (2).

- Slacken the timing belt stretcher lock nut and bolt and withdraw the belt from the timing gears and stretcher.
- Unfasten the bolts (3) and remove the coupling (4).

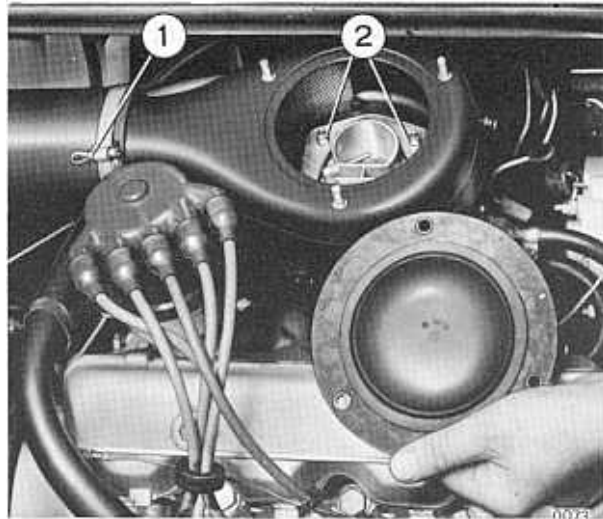

Fig. 01 2/49 - Carburettor air intake.

- Slacken the clamp (1) and withdraw the pipe.
- Remove the air intake cover, unscrew the nuts (2), withdraw the oil vapor breather pipes and remove the air intake.

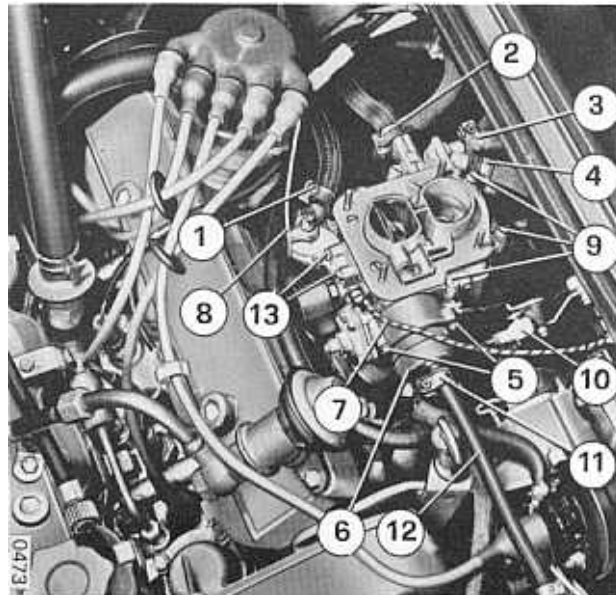

Fig. 01 2/50 Carburettor.

- Remove the pipes (1, 2, 3 and 4).
- Disconnect the accelerator control (10), disconnect the sheath retainer plate and the

throttle rod.

- Remove the bolt (11) and withdraw the pipe (12).
- Remove the brake servo vacuum pipe.



Fig. 01 2/51 - Carburettor hoses.

- Remove the hoses (1, 2 and 3).

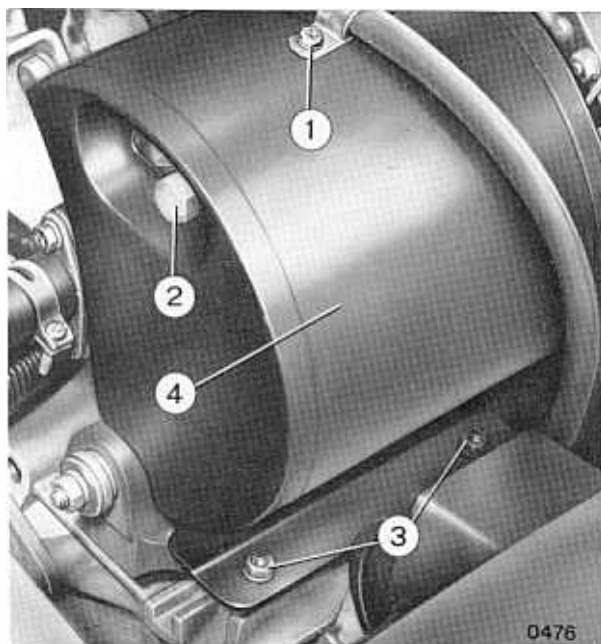

Fig. 01 2/52 - Removing air pump shield.

- Unfasten the bolts (1 and 2) and nuts (3) and remove the shield (4).

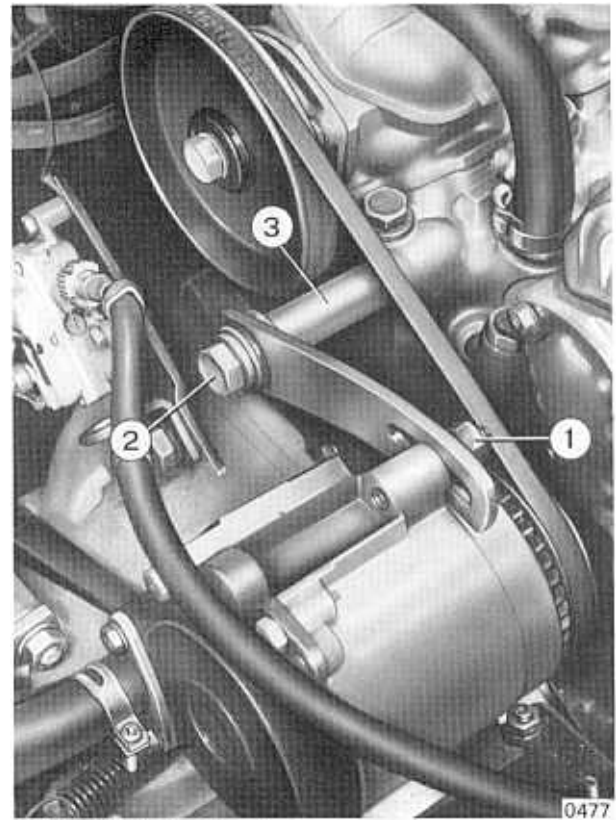

Fig. 01 2/53 - Removing air pump bracket from the cylinder head.

- Unfasten the nut (1) and remove the belt, then unfasten the bolt (2) and withdraw it along with the spacer (3).
- Remove the bolts securing the cylinder head and remove it (for partial overhaul of the head, see 01 4 2700).

Refitting

- Clean the cylinder head mating surface thoroughly and fit the gasket.
- Fit the cylinder head and tighten the bolts in the specified order and to the specified torque loading, being sure not to tighten the bolts in a single operation.
- Check tappet clearance as described at 01 2 6500 (if clearance has to be adjusted, see 01 2 6500).



Fig. 01 2/54 - Air pump belt stretcher.

- Stretch the air pump belt with tool 88013053 and torque wrench 88091134 set at the specified torque loading.
- Refit the remaining parts in the reverse order to removal.
- Refill with coolant and deaerate as described at 01 2 4650.

TOOLS REQUIRED

- 88091134
- 88091135 - Torque wrench
- 88013053 - Tool

ENGINE UNIT AND MOTIVE COMPONENTS

§ 01 2 8800

REMOVING AND REFITTING THE ENGINE (COMPLETE WITH GEARBOX), INCLUDING REMOVAL AND REFITTING OF THE GEARBOX AND CLUTCH

Stand the vehicle over the pit, fit covers
88083051 and *proceed as follows:*

Removal

From above the vehicle:

- Take off the battery leads
- Remove the spare wheel and its heat shield

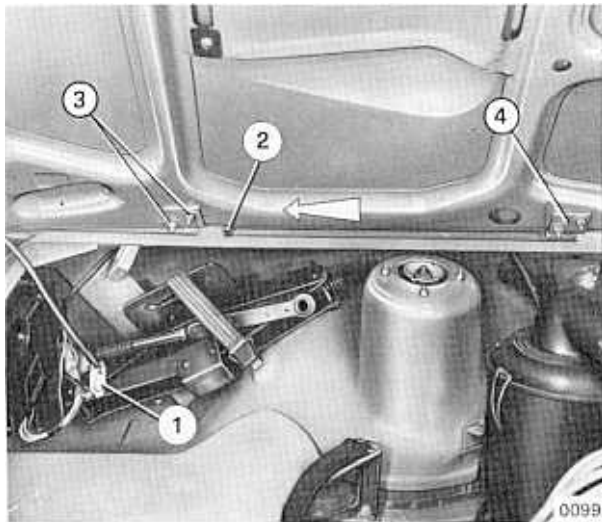

Fig. 01 2/55 - Removal of bonnet

- Disconnect the cylinder (1), undo nut (2) and slide off the bonnet in the direction of the arrow.
- Drain off the coolant as described at para. 01 2 4650

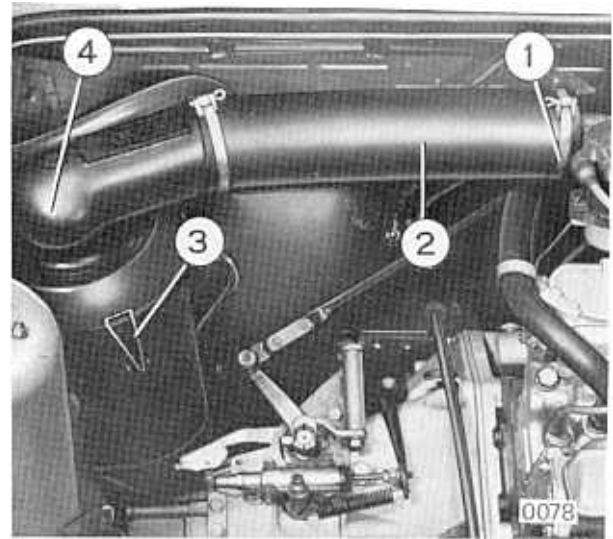

Fig. 01 2/56 - Air cleaner

- Slacken the clamp (1), slide off the pipe (2), unhook the springs (3) and remove the cover (4).
- Unscrew the bolts and take off the cleaner body.
- Detach the air intake on the carburettor.

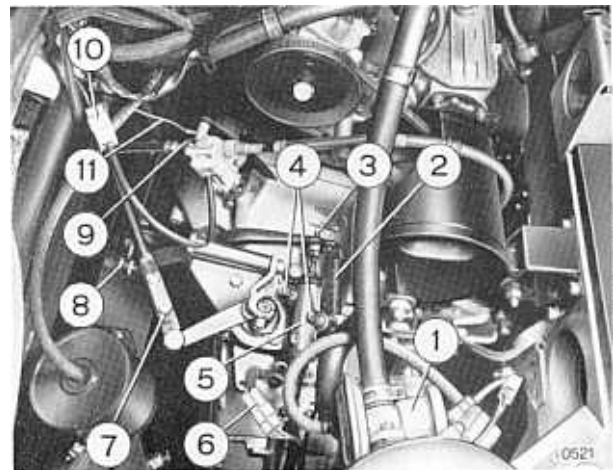
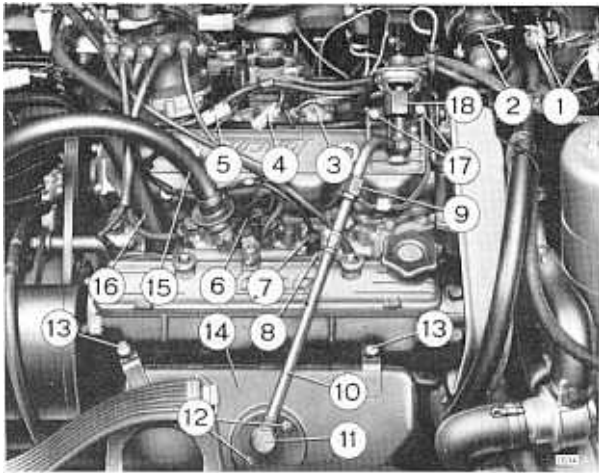
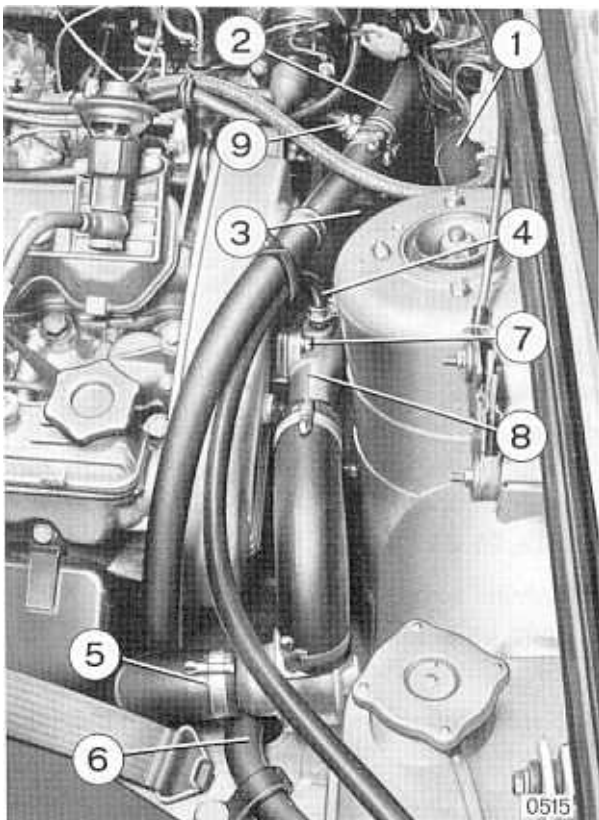

Fig. 01 2/57 - Gearbox control rods.

- Remove the valve assembly (1) as described at para. 01 2 0730.
- Unhook spring (2), extract the cotter pin (3), undo bolts (4) and take off the servo cylinder (5).
- Disconnect the cylinder (6) and the tie rods (7, 8).
- Disconnect the mileage counter cable (9) and take off the cylinder (10) and the cable (11).

Fig. 01 2/58 - Engine mounted on vehicle

- Disconnect the cylinder (1) and take off the coil (2).
- Take off leads (3, 4, 5, 6 and 7).
- Unscrew nuts (8, 9) and bolt (11). Remove pipe (10).
- Unscrew nuts (12) and bolt (13). Remove the guard (14).
- Slip off pipes (15, 16).

Fig. 01 2/59 - Water pipes

- Remove pipes (1 to 6), undo bolts (7) and take off the union (8), complete with sleeves and thermostat.

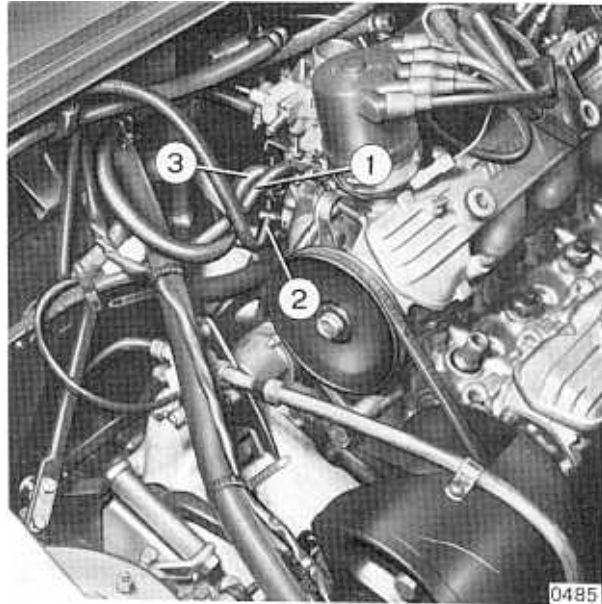
Fig. 01 2/60 - Removal of hoses

- Take off hoses (1, 2 and 3).

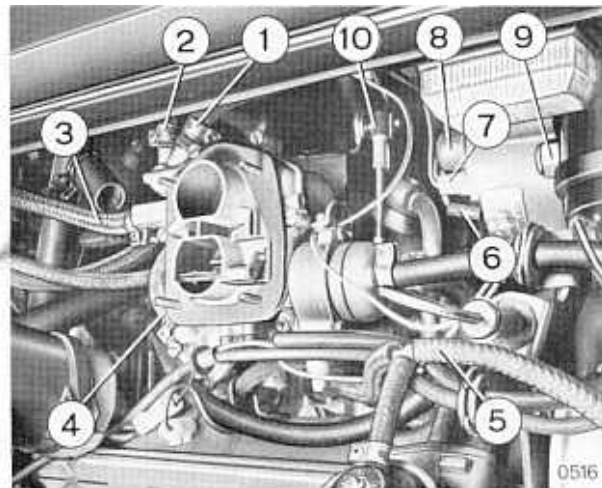
Fig. 01 2/61 - Removal of hoses.

- Take off hoses (1 to 5).
- Disconnect cables (6 and 7) and take off cable (8).
- Undo nut (9), unscrew the bolt holding the alternator. Remove the alternator and its drive belt.
- Disconnect the carburettor control rod (10) and remove the bracket, complete with sheath

and accelerator control rod, from the carburettor.

From below the vehicle

- Remove the receptacle used to collect the water and re-insert the drain plugs.
- Take off the oil filter support as described at para. 01 2 6000.
- Take off the servo unit vacuum hose.

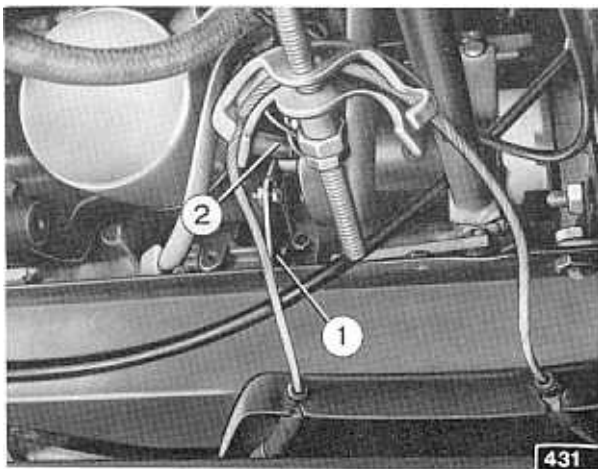

Fig. 01 2/62 - Removal of starter motor leads.

- Take off the bracket (1) and the cable (2).

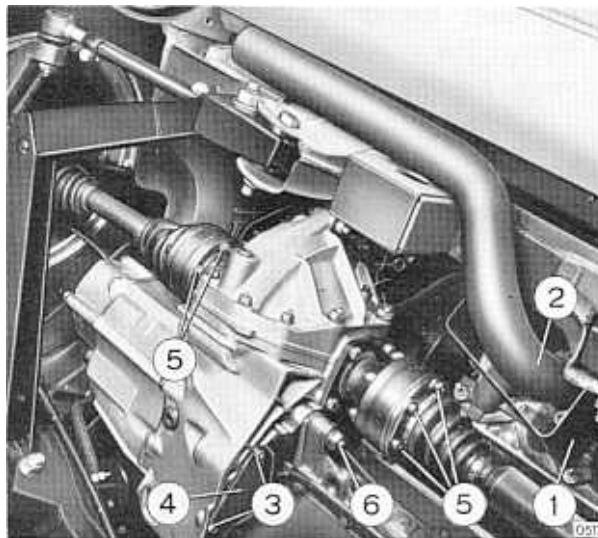

Fig. 01 2/63 - View of engine from under the vehicle

- Remove the guard (1), take off the pipe (2) from the exhaust manifold.
- Undo bolts (3) and take off the guard (4).
- Undo bolts (5) and take off the right and left

drive shaft.

- Fit engine and gearbox unit lifting arms 88017363.

From above the vehicle

- Mount a hoist above the vehicle. Attach the engine to lifting hook 88017362 and hawser 88097251, arranged as shown in photo 01 2/69. Take up the slack.

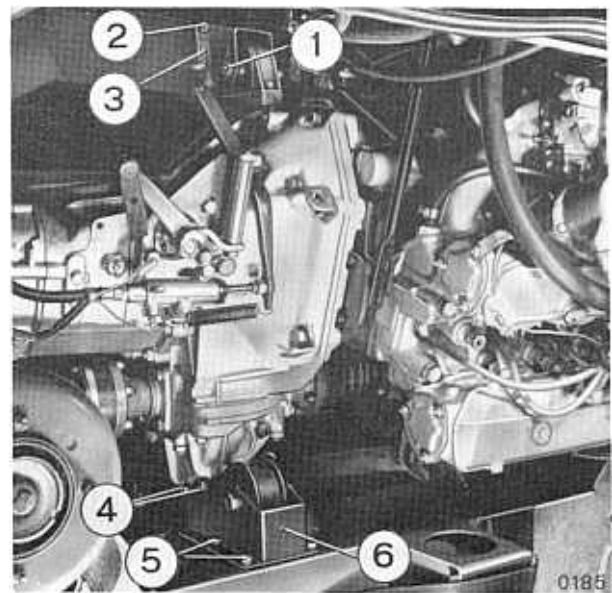

Fig. 01 2/64 - Gearbox mountings

- Unscrew and take off bolt (1), remove bolts (2) and take off mounting (3).
- Unscrew and take off bolts (4), remove bolts (5) and take off mounting (6).

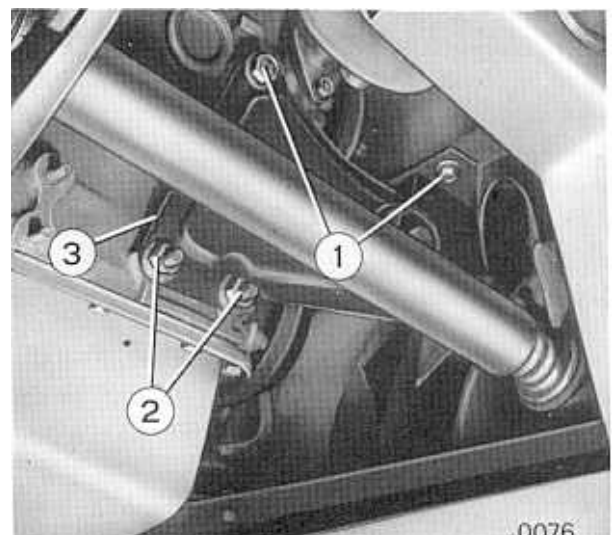

Fig. 01 2/65 - Engine mounting.

Unscrew bolts 1) and nuts (2) Take off mounting (3).

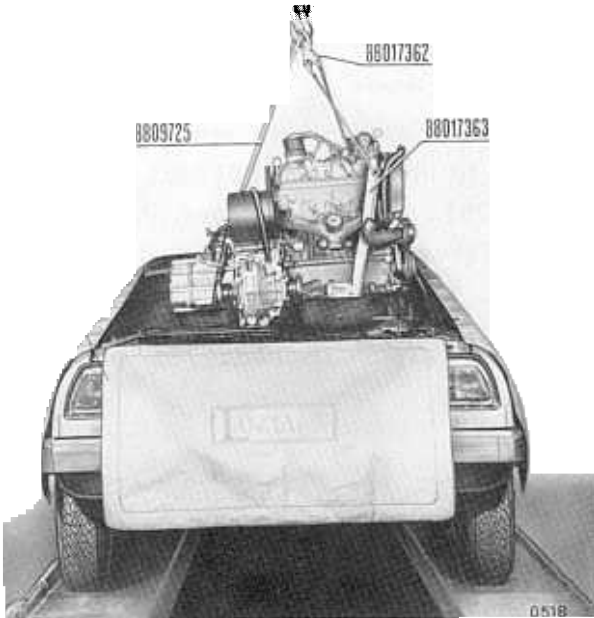

Fig. 01 2/66 - Lifting engine and gearbox unit from inside the vehicle

- Lift the engine and gearbox unit out of the vehicle and rest it on bed 88017364.
- Remove the air pump as described at para 01 2 0720 of the variant (see below).

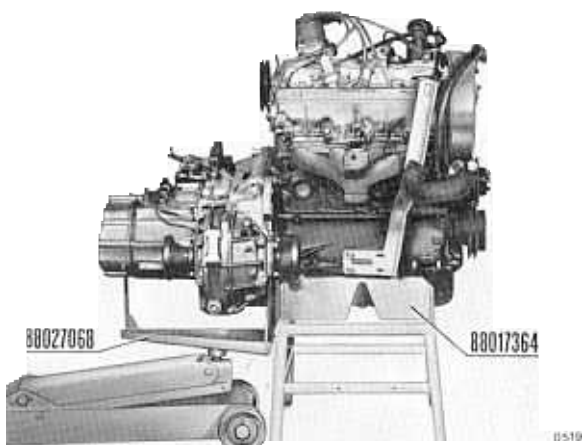

Fig. 01 2/67 - Removal of gearbox-differential from the engine on the bed.

- Fit cradle 88027068A on the gearbox. Arrange a trolley jack so that the tail of the cradle is inserted in the jack and then raise the jack slightly.
- Remove the starter motor. Undo the bolts holding the gearbox to the engine and detach

the gearbox from the engine

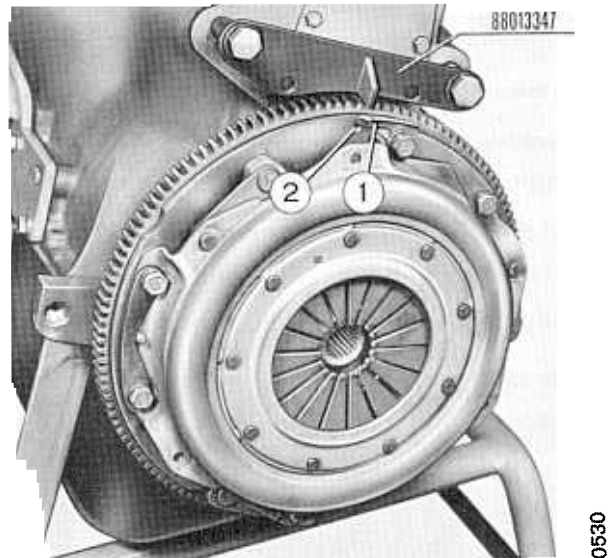

Fig. 01 2/68 Locking of flywheel with fixture 88013347.

- Lock the flywheel with fixture 88013347. Unscrew the mounting bolts and remove the pointer (1) and the clutch assembly.

Refitting

- Remount the clutch assembly. Use tool 88023030 to locate the disc. Pointer (1) must coincide with reference mark (2).
- Remount the gearbox on the engine and tighten the mounting bolts to the correct torque loading.
- Refit the remaining parts in the reverse order. On completion, fill and vent the cooling system as described at para 01 2 4650.
- Lastly, check for leaks and set the slow-running mechanism as described at para 01 2 2300.

TOOLS REQUIRED

- 88017363 - Engine gearbox unit lifting arms
- 88017362 - Engine lifting hook
- 88097251 - Hawser
- 88027068A - Gearbox cradle
- 88017364 - Bed for engine and gearbox unit after dismantling
- 88013347 - Crankshaft locking fixture
- 88023030 - Clutch disc locating tool

BASIC TYPE

The directions and operations refer to the clutch fitted to all car models.

CLUTCH GROUP CONTENTS

CHAPTER 1

Troubles, probable causes, checkings and operations to be carried out

from page 02 1/1
to " 02 1/2

CHAPTER 2

§ 02 2 0100	Checking and adjusting the clutch pedal travel	page 02 2/1
§ 02 2 0700	Removing and refitting the clutch pedal	" 02 2/1
§ 02 2 0900	Replacing the clutch release bearing	" 02 2/2
§ 02 2 1000	Removal and refitting the clutch	" 02 2/2
§ 02 2 1500	Removal and refitting of clutch master cylinder	" 02 2/3
§ 02 2 1700	Removal and refitting of operating cylinder	" 02 2/3
§ 02 2 1900	Bleeding of clutch hydraulic circuit	" 02 2/4

FAULT	PROBABLE CAUSES	CHECKS ADVISABLE BEFORE REPAIRING	ACTION NECESSARY	PARA
Gripping clutch	Slack or worn disc facings	—	Removal and refitting of clutch Renewal of clutch disc	01 2 1000 —
	Disc flexible coupling worn	—	Removal and refitting of clutch Renewal of clutch disc	02 2 1000 —
	Oil on disc facings	—	Removal and refitting of clutch Renewal of clutch disc	02 2 1000 —
Slipping clutch	No pedal free travel	—	Check and adjust clutch pedal travel	02 2 1000
	Clutch disc facings worn or brittle due to overheating, or smeared with oil	—	Removal and refitting of clutch Renewal of clutch disc Renewal of oil seal	02 2 1000 — 03 2 2600

FAULT	PROBABLE CAUSES	CHECKS ADVISABLE BEFORE REPAIRING	ACTION NECESSARY	PARA
Slipping clutch (cont'd)		—	Renewal of driving shaft rear gasket	01 2 8700
Clutch does not disengage fully	Incorrect adjustment of clutch release control Leaking circuit	Check for excess pedal free travel Look for leaks	Check and adjust clutch pedal travel Repair leak and bleed circuit	02 2 0100 02 2 1900
Clutch pedal noisy when depressed with engine running	Worn clutch release thrust bearing	—	Renew clutch release bearing	02 2 0900

CHAPTER 2

§02 2 0100

CHECKING AND ADJUSTMENT OF CLUTCH PEDAL TRAVEL

Fit covers 88083051 and *proceed as follows:*

- Check that the free travel distance of the clutch pedal is within the permitted range.

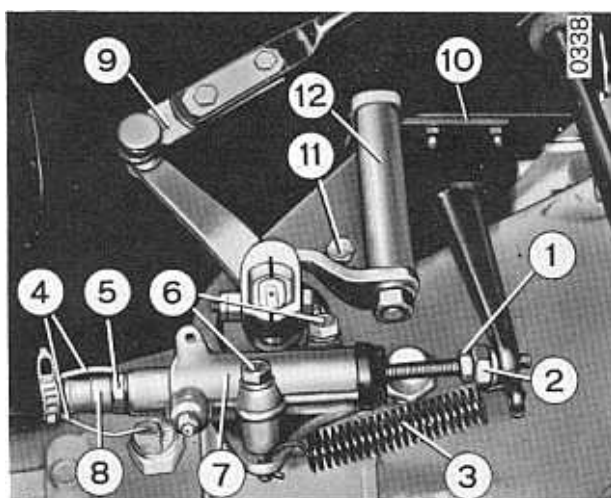

Fig. 02 2/1 - Adjustment of clutch pedal travel

- If adjustment is necessary, loosen the nut (1) and turn nut (2) in the direction required to shorten or lengthen the pedal travel to the correct distance.

§ 02 2 0700

REMOVAL AND REFITTING OF THE CLUTCH PEDAL

(not including removal and refitting the pedal bearing)

Removed the pedal bearing as described at para 12 2 1400 and *proceed as follows:*

Removal

Fit fixture 88023036 as shown in the figure and unhook the spring (1)

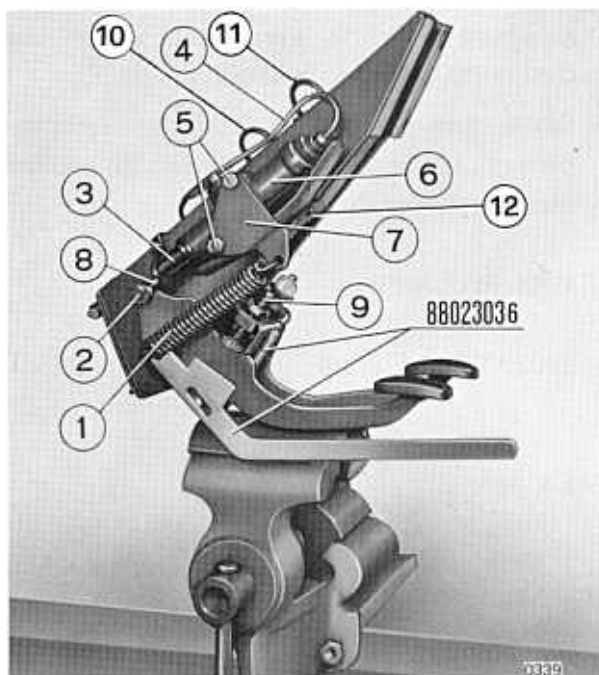

Fig. 02 2/2 - Fixture 88023036 in position for unhooking clutch pedal spring.

- Extract the split pin (2), remove the cover (3) and take off the pipe (4).
- Unscrew the bolts (5) and remove the master cylinder (6) together with the plate (7) and the push rod (8).

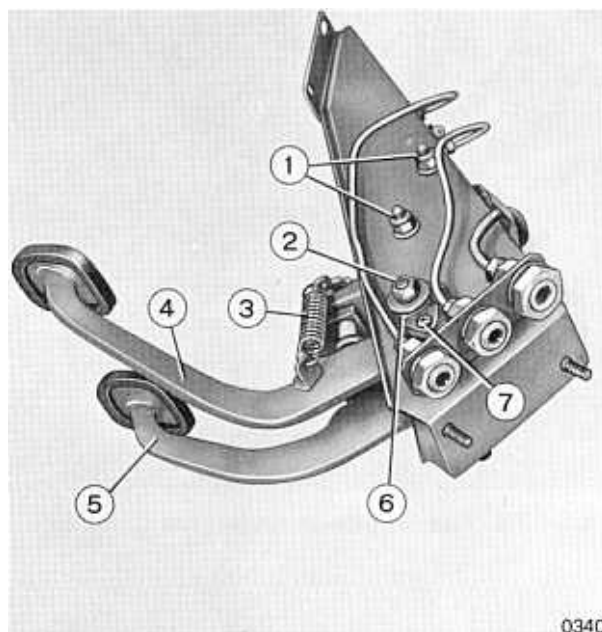

Fig. 02 2/3 - Pedal bearing

- Unscrew nut (1) and slide off clutch pedal (2).

Refitting

- Remount pedal in the reverse order. Use fixture 88023036 to re-attach spring.
- Lastly, turn screw (9) as required to reset the correct play between the push rod (8) and the master cylinder (6).

TOOL REQUIRED

88023036 - Fixture

§02 2 0900

REPLACING THE CLUTCH RELEASE BEARING

(excluding removing and refitting the gearbox-differential unit)

Remove the gearbox as described at 03 2 2500 and *proceed as follows*:

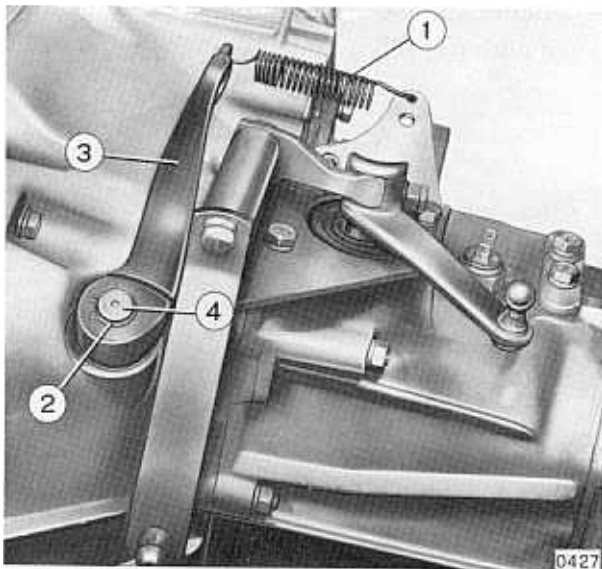

Fig. 01 2/4 - Removing clutch release lever

- Take off the spring (1), remove ring (2) using external snap ring pliers, and withdraw the lever (3) from the shaft (4).

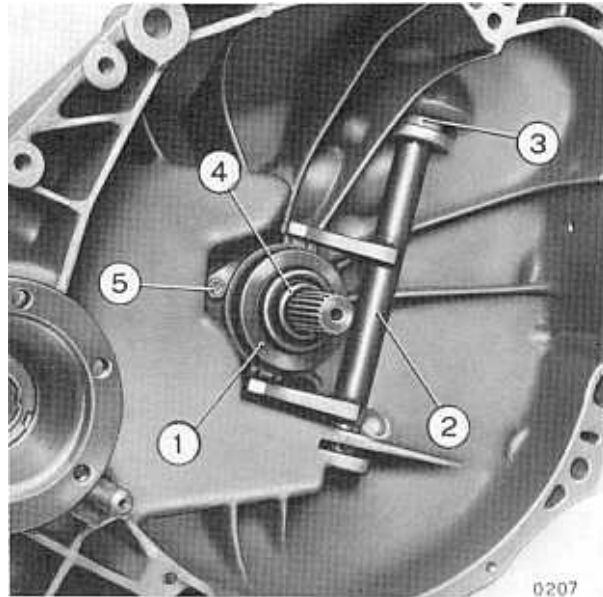

Fig. 02 2/5 - Clutch release sleeve and bearing.

- Remove the shaft (2) and withdraw the bearing (1).

§ 02 2 1000

REMOVAL AND REFITTING OF CLUTCH
(not including removal and refitting of gearbox)

Remove the gearbox as described at para 03 2 2500 and *proceed as follows*:

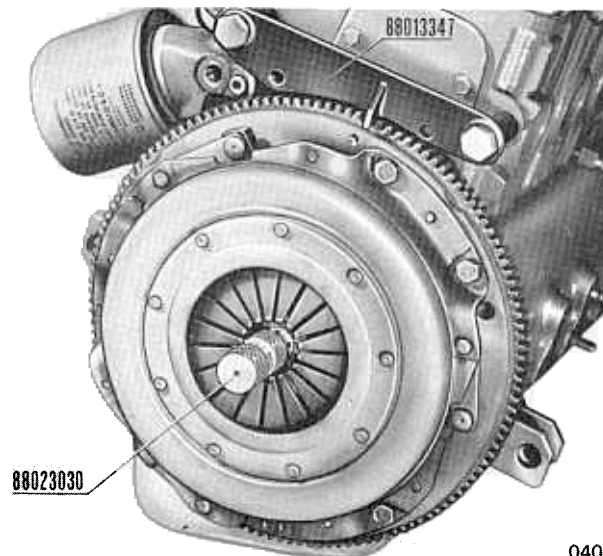

Fig. 02 2/6 - Clutch with fixtures 88013347 and 88023030 attached

- Lock the flywheel with fixture 88013347. Unscrw bolts holding the pressure plate and

remove pressure plate and clutch disc.

- Check the pressure plate for wear or defects and renew if necessary.
- Check the clutch side of the flywheel for scratches or wear necessitating its removal for overhauling or replacement (see 01 2 8610 and 01 3 2300 for removal and checking of the flywheel respectively).

Refitting

- Use fixture 88023030 to centre the disc when remounting the clutch. Refit the gearbox as described at para 03 2 2500.

TOOLS REQUIRED

- 88013347 - Fixture to lock flywheel
- 88023030 - Fixture for centering clutch disc.

§ 02 2 1500

REMOVAL AND REFITTING OF CLUTCH MASTER CYLINDER (not including removal and refitting of pedal bearing)

Remove the pedal bearing as described at para 12 2 1400 and *proceed as follows:*

Removal

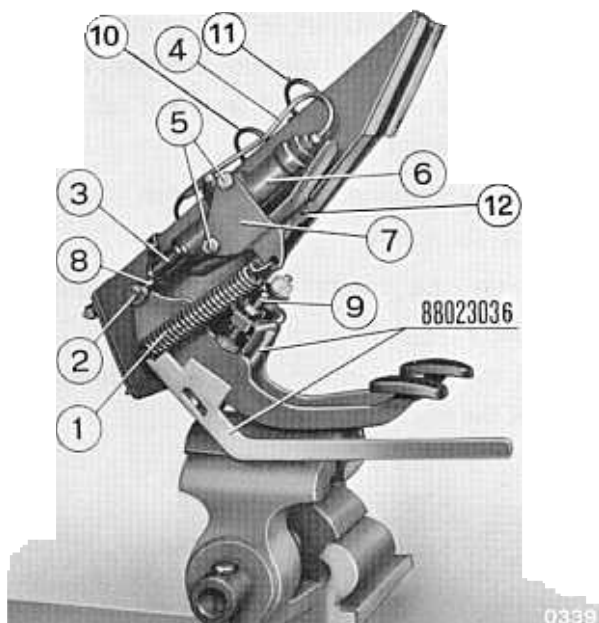

Fig. 02 2/7 - Fixture 88023036 in position for unhooking clutch pedal spring

- Extract the split pin (2), remove the cover (3) and take off the pipe (4).
- Unscrew the bolts (5) and remove the master cylinder (6) together with the plate (7) and the push rod (8).

Refitting

- Remount in the reverse order. Use fixture 88023036 to re-attach the spring.

TOOL REQUIRED

- 88023036 - Fixture

§ 02 2 1700

REMOVAL AND REFITTING OF OPERATING CYLINDER (not including bleeding)

Removal

- Syringe out the fluid from the cylinder
- Remove the spare wheel

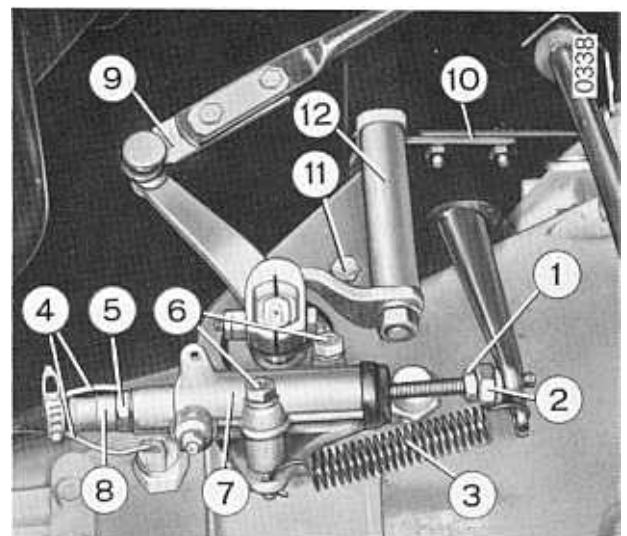

Fig. 02 2/8 - Clutch linkage

- Unhook the spring (3), slip off the wires (4) and place a suitable form of protection against the fluid that may leak out of the hose (8).
- Undo nut (5), unscrew bolts (6) and

disconnect the operating cylinder (7) from the hose (8).

Refitting

- Reassemble in the reverse order and bleed the circuit as described at para 02 2 1900.

§ 02 2 1900

BLEEDING OF CLUTCH HYDRAULIC CIRCUIT

Note: When refilling or topping up the circuit, always use new fluid of the recommended type. Never reuse liquid salvaged during bleeding.

Fit covers 88083051 and *proceed as follows:*

- Fill up the clutch cylinder reservoir to the full level shown with fluid of the recommended type.
- Work the clutch pedal up and down to pump the fluid into the pipes. If the level in the reservoir falls to the "empty" mark, add more fluid.

N.B. - When filling and bleeding the circuit, make sure that the "empty" level is not passed, since this would result in letting air into the circuit.

- Take a glass container and fill it with a small quantity of fluid.
- Place one end of a 30-40 cm. flexible hose (preferably made of transparent plastic) in the liquid in the container and attach the other end to the bleed screw.
- Place the container at least 20 cm higher than the bleed screw, so that liquid escaping from the screw must climb a certain distance.



Fig. 02 2/9 - Bleeding the clutch hydraulic circuit

- Press the clutch pedal and slacken the bleed screw. When the pedal is pressed right down, a mixture of fluid and air will pass up the hose.
- Hold the pedal down and tighten the bleed screw. Release the pedal, and again press it and undo the screw.
- Continue this operation until the fluid reaching the container is free of air bubbles. As already stated, top up the reservoir as required so that the fluid does not fall below the empty level.
- Hold the pedal down for the last time and tighten the screw.
- Top up the master cylinder reservoir if necessary.
- Work the pedal up and down a few times and check the circuit for leaks.

BASIC TYPE

The directions and operations refer to the gearbox-diff. unit fitted to all car models

VARIANTS

– **Variant SCORPION**

The directions and operations refer to the gearbox-diff. units fitted to the SCORPION version only.

GEARBOX GROUP CONTENTS

CHAPTER 1

Troubles, probable causes, checkings and operations to be carried out

from page 03 1/1
to " 03 1/3

CHAPTER 2

§ 03 2 0200	Removing and refitting gear lever	page	03 2/1
§ 03 2 0510	Removing and refitting gear control idler lever	"	03 2/2
§ 03 2 0600	Adjusting the gear control linkage	"	03 2/2
§ 03 2 0100	Removing and refitting lever support for replacing of silent blocks	"	03 2/2
§ 03 2 0200	Replacing a silent block for gearbox lineage joints	"	03 2/3
§ 03 2 1300	Removing and refitting the gearbox front and rear mounting buffers	"	03 2/3
§ 03 2 2200	Removing and refitting the gearbox rear cover and renewing the gasket	"	03 2/4
§ 03 2 2300	Renewing the diff. side gear oil seal	"	03 2/4
§ 03 2 2500	Removing and refitting the gearbox-diff. unit	"	03 2/5
	Dor for SCORPION cars	"	03 2/1 Variant SCORPION
§ 03 2 2600	Renewal of main shaft oil seal	"	03 2/7

CHAPTER 3

§ 03 3 0100	Disassembling and reassembling the gearbox, and main and driven shafts		03 3/1
§ 03 3 0400	Overhaul of synchronizers and renewal of bearings and drive shaft parts if necessary		03 3/7
§ 03 3 1000	Renewal of main shaft or its bearings		03 3/10
§ 03 3 1000	Overhauling the differential		03 3/11

FAULT	PROBABLE CAUSES	CHECKS ADVISABLE BEFORE REPAIRING	ACTION NECESSARY	PARA
Gear engagement noisy or difficult	Front shaft stay rod out of adjustment	—	Adjust stay rod	03 2 0600
	Idler lever not lubricated	—	Removal and refitting of idler lever	03 2 0510
	Rear shaft and lever out of alignment	—	Removal and refitting of rear shaft lever	03 2 0100
	One or more stay rod ends worn out	—	Removal and refitting of rear shaft lever and, if necessary: removal and refitting of front shaft; removal and refitting of front shaft support rod	03 2 1200
	Worn synchronizers	—	Removal and refitting of gearbox Overhaul of synchronizers and renewal of driven shaft bearings and other parts, as required	03 2 2500 03 3 0400
	Clutch fails to disengage completely	—	Adjustment of clutch pedal travel	02 2 0100

FAULT	PROBABLE CAUSES	CHECKS ADVISABLE BEFORE REPAIRING	ACTION NECESSARY	PARA
Gear engagement noisy or difficult	One or more gears worn out	Check whether noise occurs in any particular gear	Removal and refitting of gearbox Overhaul of driven shaft Check main shaft	03 2 2500 03 3 0400 03 3 0700
	Worn driven shaft front or rear bearing, or differential bearing	Check whether noise is continuous in all gears when driving	Removal and refitting of gearbox Renewal of driven shaft bearings Overhaul of differential	03 2 2500 03 3 0400 03 3 1000
	Worn main shaft front or rear bearing	Check whether noise stops on disengaging the clutch	Removal and refitting of gearbox Renewal of main shaft bearings	03 2 2500 03 3 0700
	Worn spur gears	Check whether noise is more noticeable when engine pulling or when driving at high speed	Removal and refitting of gearbox Overhaul of differential	03 2 2500 03 3 1000
Backing lights do not come on when reverse gear engaged	Light switch out of order	Short-circuit switch wires and see whether lights come on	Removal and refitting of backing lights switch	-

FAULT	PROBABLE CAUSES	CHECKS ADVISABLE BEFORE REPAIRING	ACTION NECESSARY	PARA
Gearbox knocks during sudden acceleration	Worn gearbox mounting buffers	—	Removal and renewal of gearbox mounting buffers	03 2 1300
Gear lever vibrates	Gear-lever-to-rear-shaft mounting nut loose	Check whether nut loose by looking through gearbox inspection hole in floor pan	Tighten nut and, if necessary, removal and refitting of rear shaft and lever	
Oil leaks from gearbox	Worn diff. side gear oil seals	Look for leaks from side gears	Renew oil seal on gearbox side Renew oil seal on engine side	03 2 2300 —
	Worn gearbox rear cover gasket	Look for leaks from rear cover	Removal and refitting of rear cover to renew gasket	03 2 2200
	Worn clutch release sleeve support and main shaft oil	Look for leaks from the bottom of the flywheel guard	Renewal of oil seal (up to No.) Ditto (from No.)	03 2 2600

CHAPTER 2

§ 03 2 0100

REMOVING AND REFITTING GEAR LEVER

Proceed as follows:

Removing

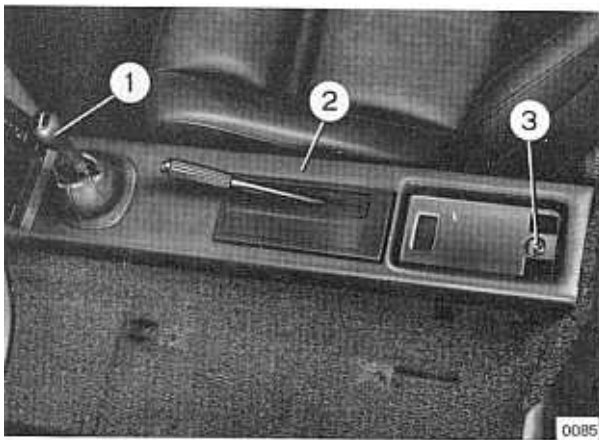

Fig. 03 2/1 - Tunnel trim panel

- Remove the lock nut and unscrew the knob (1), then remove the bolt (3) and take off the trim panel (2).
- Remove the bolts holding the gear lever support to the tunnel.

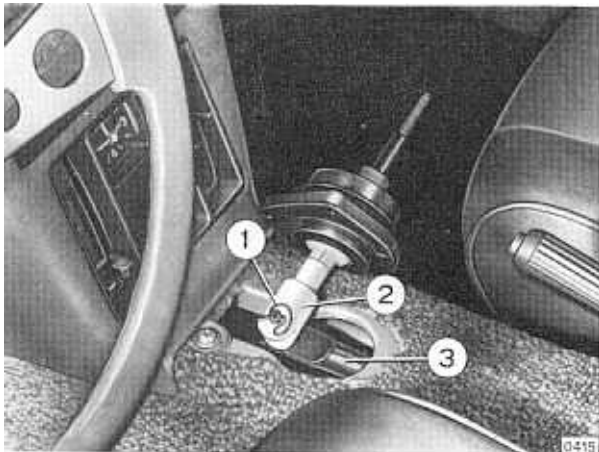

Fig. 03 2/2 - Removing lever from the front rod

- Withdraw the spring (1) and disconnect the lever (2) from the rod (3).

At the bench

Turn the lever support with respect to the cover and separate them, then open the half-joints and remove the grommet and lever cup.

- Replace any worn or deformed parts.

Refitting

- Refit in the reverse order to the removal.

§ 03 2 0510

REMOVING AND REFITTING GEAR CONTROL IDLER LEVER

Drive the car over the pit, fit covers 88083051 and *proceed as follows:*

Above the car

- Remove the spare wheel.
- Disconnect the gear lever at the idler shaft side.

Disconnect the idler shaft from the plastic block clamping it to the body.

Below the car

- Unfasten the securing bolts and remove the shroud.
- Disconnect the rear rod and take out the idler shaft.
- Remove the idler shaft silent block from the cross member.
- Carry out refitting operations in the reverse order to removal, using pliers 88539061 for reconnecting levers with snap engagement blocks.

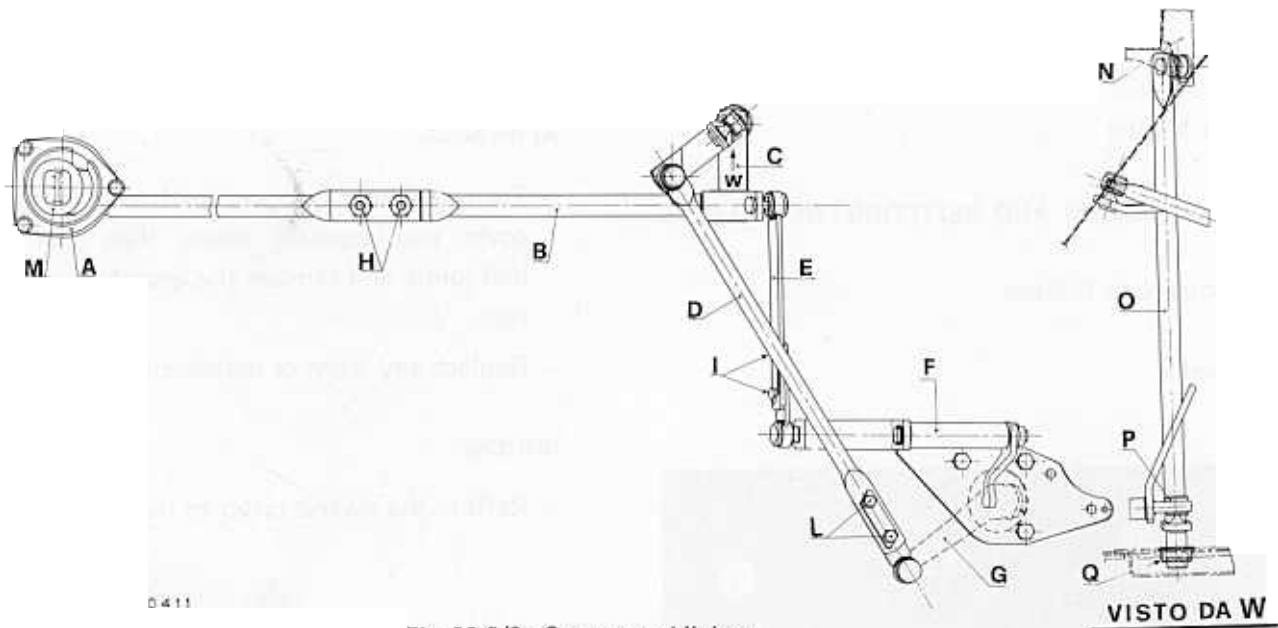

Fig. 03 2/3 - Gear control linkage

§ 03 2 0600

ADJUSTMENT OF GEAR CONTROL LINKAGE

Stand the vehicle over the pit, fit covers 88083051 and *proceed as follows*:

- Remove the spare wheel
- Hold the gear lever upright and make sure that the gearbox is in neutral
- Take off the rear air duct
- Slacken bolts (H) of the rear rod (B) and connect gear engagement lever (D) to lever (G). If this is not possible, slacken bolts (L), adjust the length of the tie rod as required, fully tighten bolts (L) and bend back the safety plates.
- Connect lever (E) to the gear selector lever. If this is not possible, slacken bolts (I), adjust the length of the rod as required, fully tighten bolts (I) and bend back the retainer plate.
- Fully tighten bolts (H), release the gear lever from its upright position and engage all gears. This must be possible without undue effort. In addition, the lever must still be able to travel a short distance inwards after engagement of the gear.
- Remount the rear air duct
- Refit the spare wheel.

§ 03 2 1100

REMOVING AND REFITTING LEVER SUPPORT FOR REPLACING OF SILENT BLOCKS

Fit the covers 88083051 and *proceed as follows*:

Removing

- Take out the spare wheel.

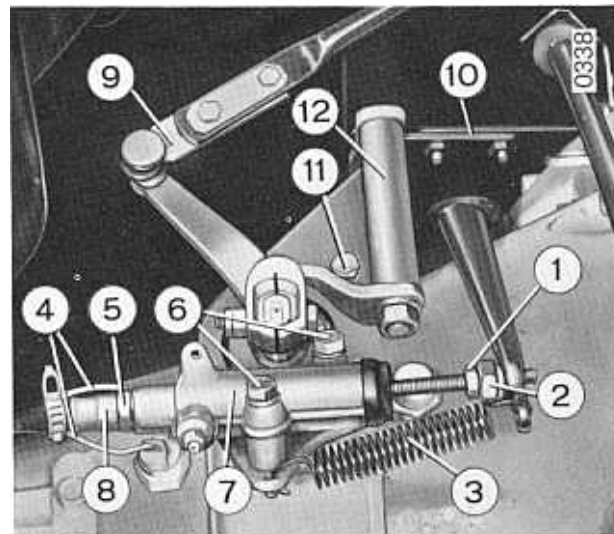

Fig. 03 2/4 - Gearbox linkage

- Remove lever (9) and lever (10).
- Remove the wires (4), unhook the spring (3), unfasten the bolts (6) and take off the operating cylinder (7).

- Unfasten bolts (11), remove the support (12) and withdraw it by way of the engagement lever.

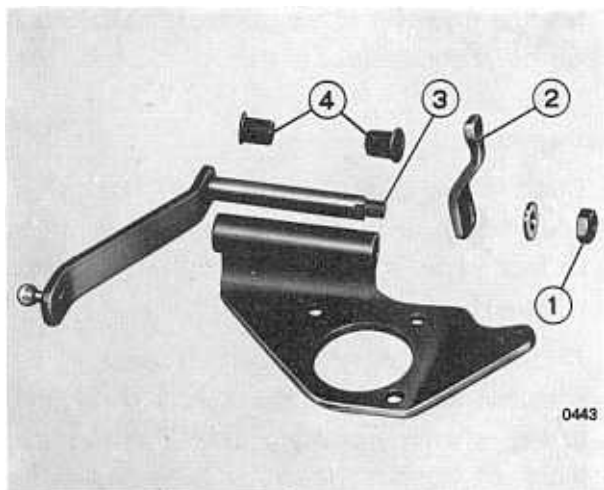

Fig. 03 2/5 - Lever support.

- Unfasten the nut (1) and remove the lever (2), then withdraw the lever (3) and recover the bushings (4).
- Clean and dry the parts and replace the plastic bushings (4) if they are worn.

Refitting

- Refit the parts in the reverse order, using pliers 88539061 for refitting the control and idler levers.

§ 03 2 1200

REPLACING A SILENT BLOCK FOR GEARBOX LINKAGE JOINTS

Proceed as follows:

- Force the silent block from its seat using the punch of tool 88022122.

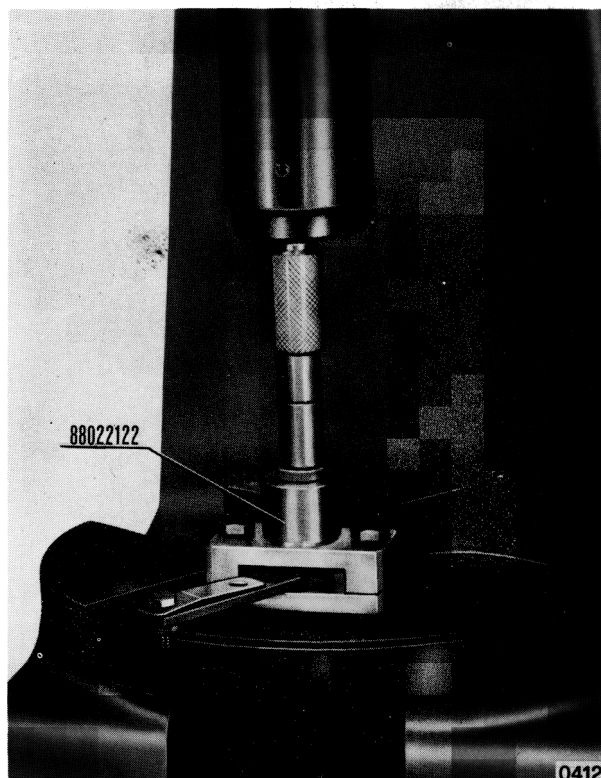

Fig. 03 2/6 - Fitting silent block using tool 88022122

- Working at the press, fit the silent block by positioning the part in question and tool 88022122 as shown in the figure.

TOOLS REQUIRED

- 88022122 - Tool

§ 03 2 1300

REMOVAL AND RENEWAL OF GEARBOX FRONT AND REAR MOUNTING BUFFERS

Stand the vehicle over the pit, fit covers 88083051 and *proceed as follows:*

- Place a post lift under the vehicle. Insert a block of wood under the gearbox and lift it to take the strain off the buffer retaining bolts.
- Remove the spare wheel via the engine compartment.

N.B. - It is safer not to attempt to remove both buffers at the same time.

Removal of rear support

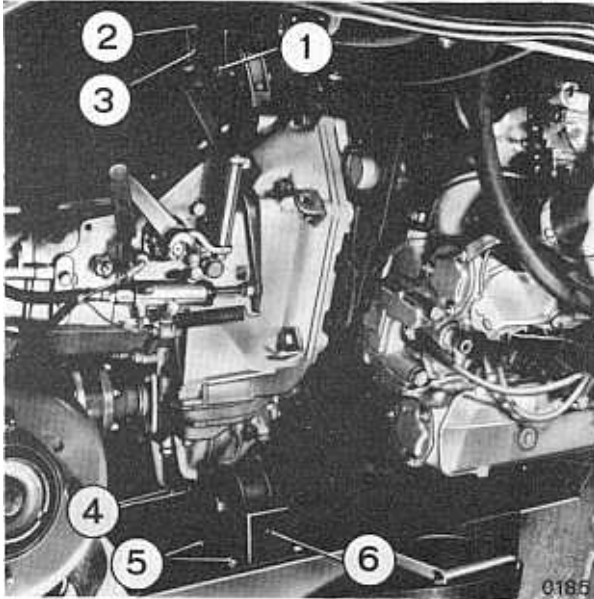

Fig. 03 2/7 - Gearbox mounting buffers

- Unscrew the respective mounting nuts and remove bolts (1) and (2). Take off the bracket (3) with its buffer.
- Use extractor 88032052 and a press to remove the buffer from the support and insert the new buffer.
- Reassemble in the reverse order.
- Removal of front support
- Unscrew screws (4), remove bolt (5) and take off the bracket (6). Unscrew the support mounting nuts and remove the support from the gearbox.
- Use extractor 88032052 and a press to renew the buffer.
- Reassemble in the reverse order.

§ 03 2 2200

REMOVAL AND REFITTING OF REAR
GEARBOX COVER AND RENEWAL OF
GASKET

Stand the vehicle over the pit, fit covers 88083051 and *proceed as follows*:

Removal

- Take off the spare wheel and unscrew the cover (top part) locking bolts
- Drain off the oil, unscrew the other bolts holding the cover to the gearbox, and take off the cover complete with its gasket.

At the bench

- Clean the cover and blow dry with compressed air. Set the cover surface on a surface plate and check for distortion with Prussian blue.
- If distortion is such that it cannot be compensated for by the thickness of the gasket when remounting, the cover surface must be rubbed down as necessary with emery cloth.

Refitting

- Clean the cover contact surface on the gearbox. Mount a new gasket and then tighten the cover locking bolts to the correct torque loading. Refill the gearbox with oil.
- Remount the spare wheel.

§ 03 2 2300

RENEWAL OF DIFFERENTIAL SIDE GEAR
OIL SEALS

Stand the vehicle over the pit and *proceed as follows*:

Removal

- Unscrew plug (6) and drain off some of the gearbox oil.
- Unscrew the bolt and mounting bolts and take off the bracket (3).
- Unscrew the bolts (5) holding the constant-velocity joint to the flange and move the drive shaft to one side.
- Uncrimp the ring nut holding the flange, mount tool 88023412 and use spanner

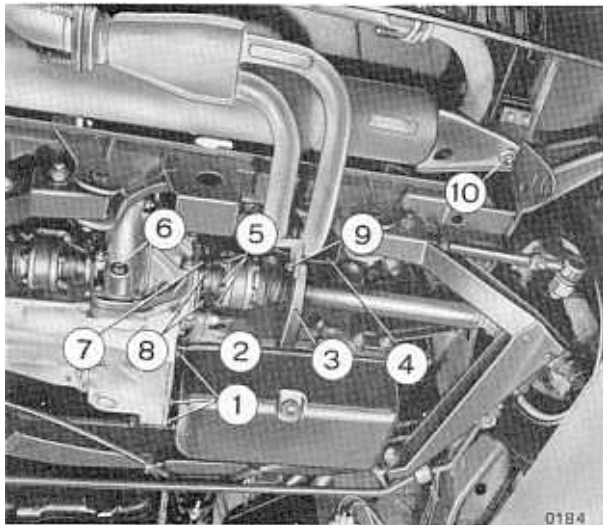

Fig. 03 2/8 - Underside of gearbox and transmission

88021411 to unscrew the ring nut and take off the flange.

Unscrew bolts (8) and remove the cover (7) and its oil seals.

On the bench

- Clean the cover with paraffin and knock off the oil seal.
- Use a press to drive in a new seal with driver 88012161.
- Renewal of the left-hand seal is carried out in the same way after raising the gearbox on a pillar lift so as to take the strain off the left suspension and facilitate uncrimping of the flange mounting ring nut.

Refitting

- Reassemble in the reverse order. Tighten the cover mounting bolts (7), ring nut, and joint-to-flange bolts to the correct torque loadings.

§ 03 2 2500 Variant

REMOVAL AND REFITTING OF GEARBOX AND DIFFERENTIAL UNIT

Stand the vehicle over the pit, fit covers 88083051 and *proceed as follows:*

Removal

From above the vehicle:

- Disconnect the positive battery lead

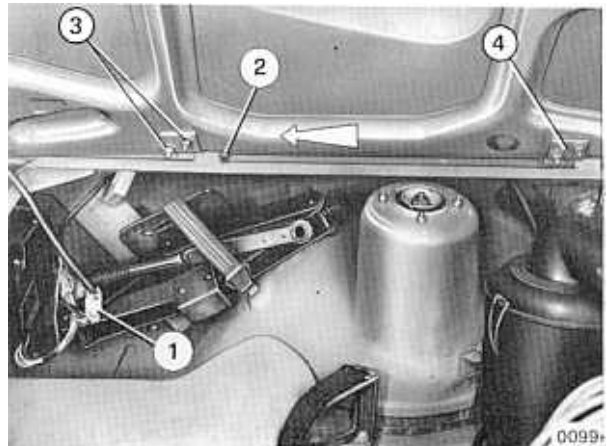

Fig. 03 2/9 - Removal of engine compartment cover

- Remove the spare wheel, detach the block (1), unscrew the nut (2) and slide off the engine compartment cover in the direction shown by the arrow.

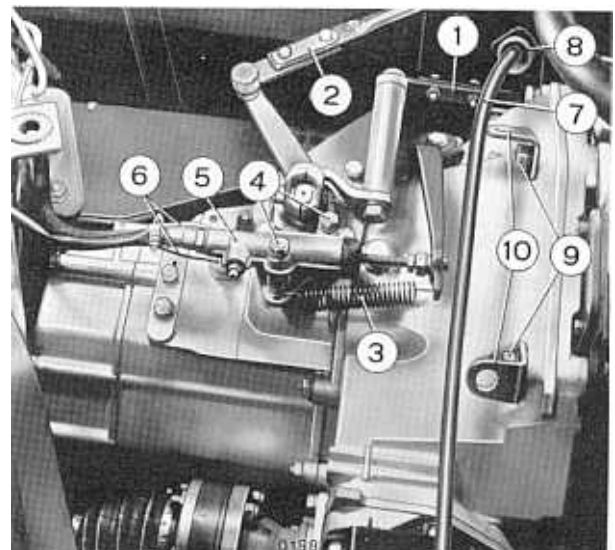

Fig. 03 2/10 - Gearbox linkage

- Detach gear selector rods (1) and (2)
- Detach the spring (3), unscrew the bolts (4) and take off the operating cylinder (5).
- Disconnect the backing lights switch leads (6).
- Disconnect the milometer cable (7) from the differential and slide it out through the slot (8).
- Unscrew the engine-gearbox junction bolt on

the starter motor side, unscrew bolts (9) and collect the plates (10).

- Slacken the rear left wheel retaining bolts.

From under the vehicle:

- Raise the rear part of the vehicle and rest it on trestles.
- Take off the left back wheel

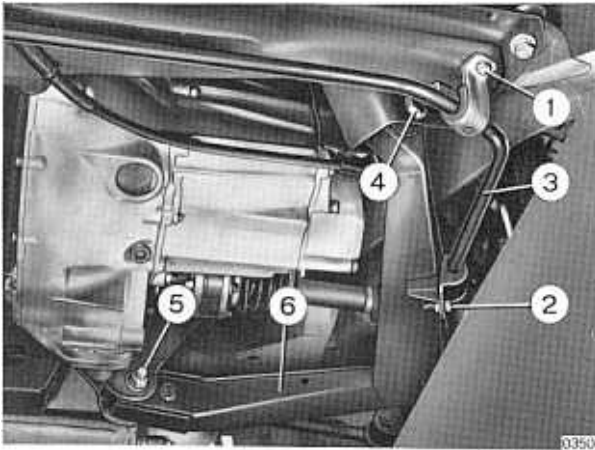

Fig. 03 2/11 - Removal of rear arm and torsion bar

- Remove the left and right half-shafts from the differential flange
- Detach the hand brake cable sheath from the arm.
- Unscrew bolts (1) and (2) and detach the torsion bar (3) from the left side, then unscrew bolts (4) and (5) and take off the arm (6).

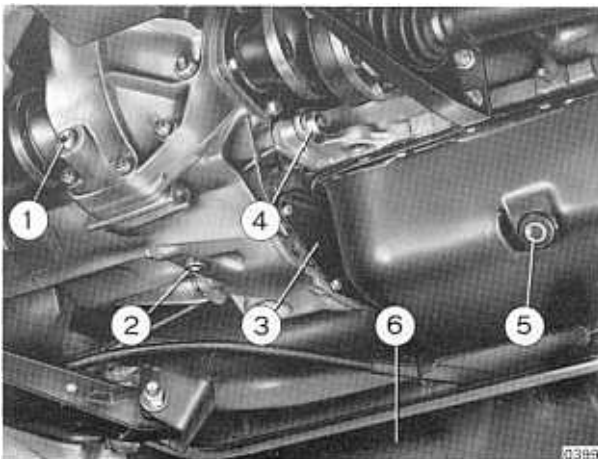

Fig. 03 2/12 - View of dust guards.

- Remove guards (1) and (2) and unscrew the nut (3).

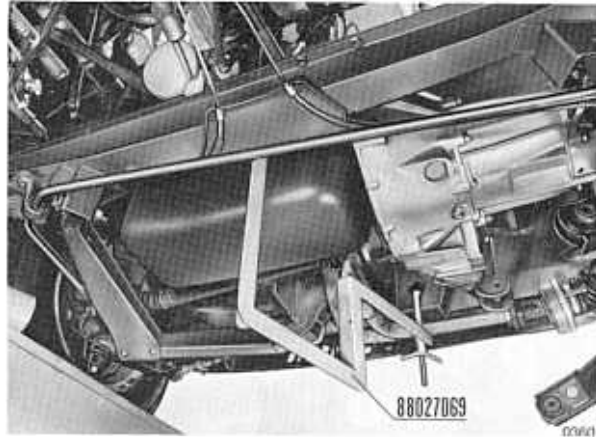

Fig. 03 2/13 Fixture 88027069 used to support the engine

- Set fixture 88027069 to support the engine, as shown in the figure.
- Remove the starter motor as described at 14 2 6900.

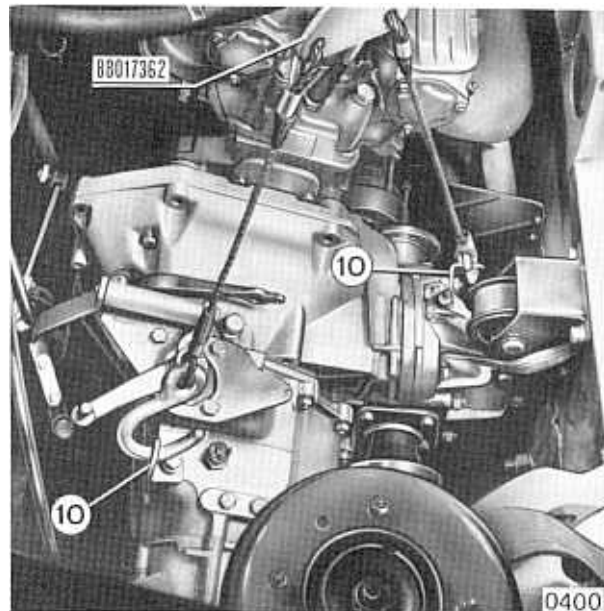

Fig. 03 2/14 - Lifting out gearbox with hook 88017362.

- Set the plates (10) of fig. 03 2/10 as shown in the figure and then apply hook 88017362 and stretch the cable slightly.

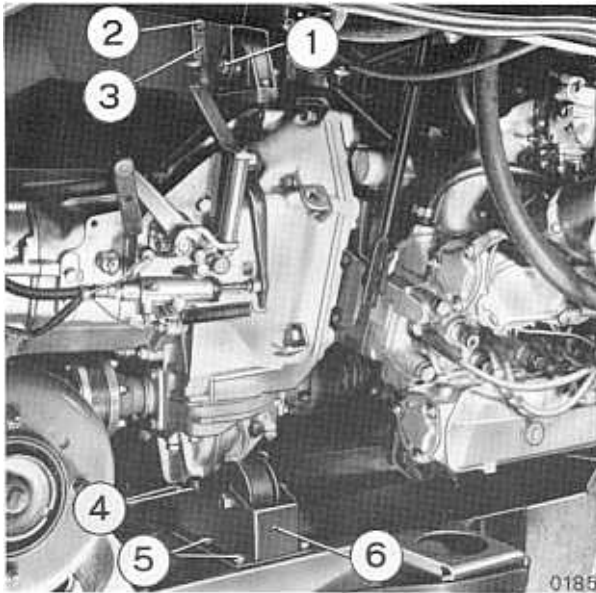

Fig. 03 2/15 - Gearbox supports

- Unscrew and withdraw the bolt (1), remove bolts (2) and then remove the support (3).
- Unscrew and withdraw the bolts (4), remove bolts (5) and then remove the support (6).
- Move the gearbox-differential unit back and manoeuvre it out from below the car (a second mechanic must help with this operation to prevent the gearbox interfering with the rear arm removed earlier).
- Detach the plate between gearbox and engine.

Refitting

- Refit the gearbox in the reverse order, - tightening bolts and nuts to their respective torque loadings; remember that left rear arm securing bolts should be tightened with static load in car.

TOOLS REQUIRED

- 88027069 - Engine support fixture
- 88017362 - Lifting hook

§ 03 2 2600

RENEWAL OF MAIN SHAFT OIL SEAL (not including removal and refitting of gearbox)

Remove the gearbox as described at para. 03 2 2500 and *proceed as follows*:

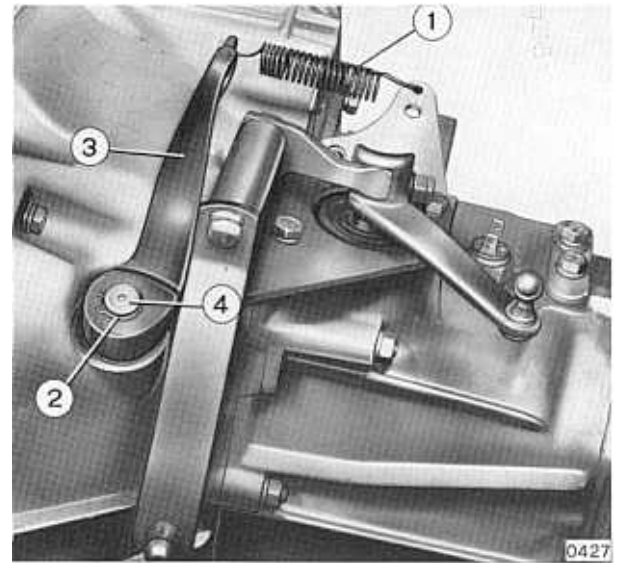

Fig. 03 2/16 - Gearbox on trestle

Remove spring (1), use circlip pliers to remove circlip (2) and slide off lever (3) from the shaft (4).

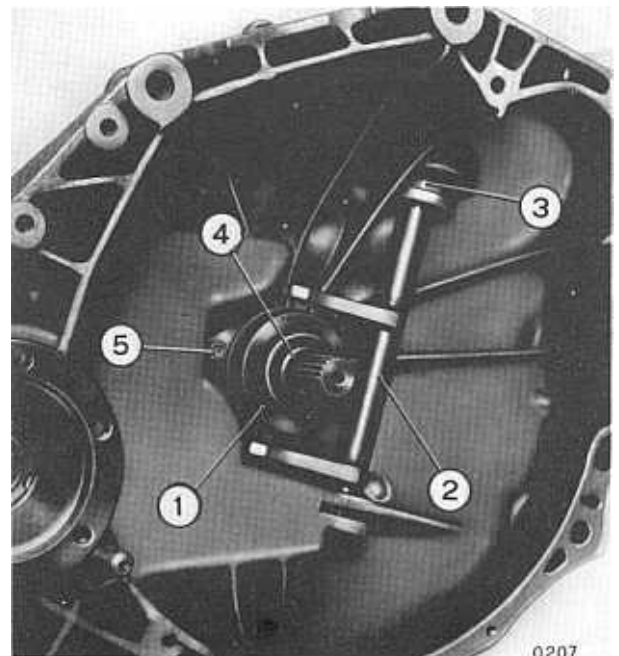

Fig. 03 2/17 - Clutch disengagement sleeve and bearing.

- Remove shaft (2) and slide off bearing (1). Unscrew bolts (5) and take off support (4). Take the seal off this support.
- Use tool 88022080 to introduce a new seal on the support and remount in the reverse order.
- Refit the gearbox as described at para. 03 2 2500.

TOOL REQUIRED

- 88022080 - Driver

CHAPTER 3

§ 03 3 0100

DISASSEMBLY AND REASSEMBLY OF GEARBOX AND MAIN AND DRIVEN SHAFTS

Proceed as follows.

Disassembly

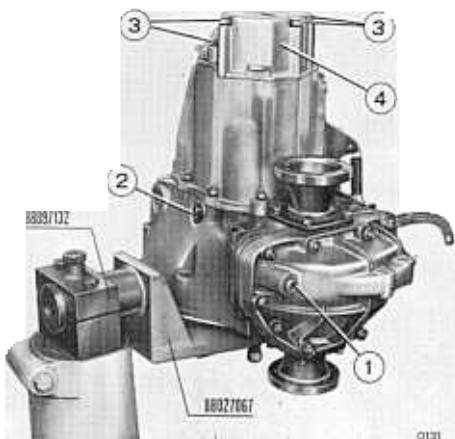

Fig. 03 3/1 - Gearbox mounted on stand 88027067

- Drain off the oil via plugs (1) and (2), assemble stand 88027067 with fitting 88097132 on column 88097130, and mount gearbox on stand; unscrew bolts (3) and take off the cover (4).

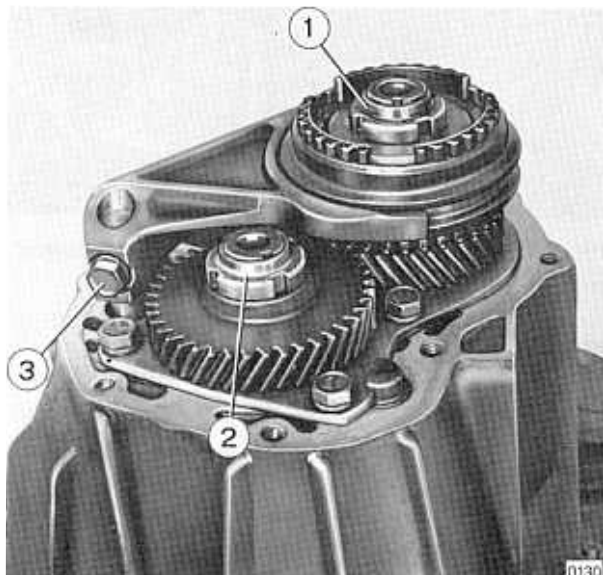

Fig. 03 3/2 - Fifth gear gears and controls

- Uncrimp ring nuts (1) and (2) and unscrew bolt (3)

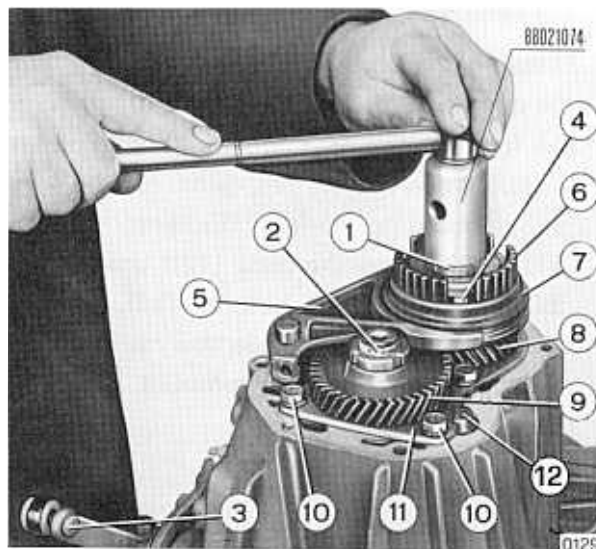

Fig. 03 3/3 - Fifth gear engaged (fork and selector rod released)

- Engage fifth gear by hand and use lever (3) to engage any other forward gear. Use spanner 88021074 to unscrew ring nuts (1) and (2). Watch for the snap-release of the rollers (4). Slide off the fork (5) and the assembly consisting of the hub (6), sleeve (7) and gear (8) with synchroniser. Then remove gear (9),

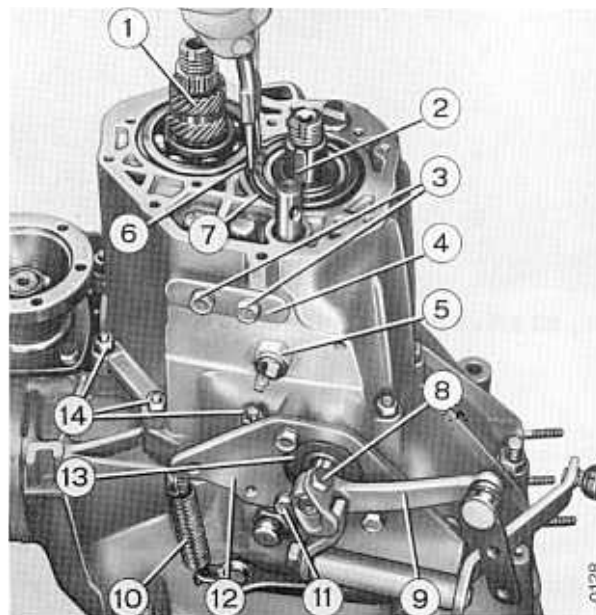

Fig. 03 3/4 - Removal of bearing snap rings

unscrew bolts 10) and take off the plate (11).

- Disengage the selected gear.
- Slide off bushing (1) and key (2). Unscrew bolts (3), take off the cover (4) and remove the springs and rod release balls.
- Unscrew the backing lights switch (5). Bring the apertures of the snap rings (6) and (7) to the front and remove with a suitable pair of pliers. Unscrew bolt (8), slide off the lever (9), unhook the spring (10), unscrew bolts (11) and remove the plate (12). Use spanner 88021075 to release bushing (13), unscrew bolts (14), and tap the gearbox casing with a mallet until it can be removed as shown below.

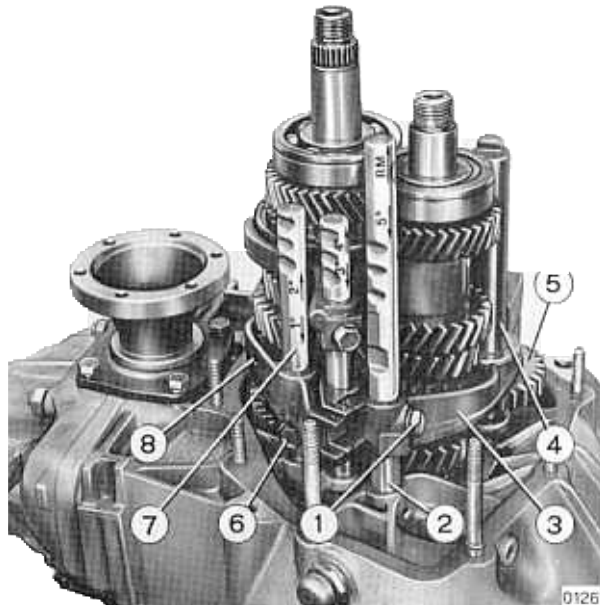

Fig. 03 3/6 - Gear selector rods and reverse gear shaft

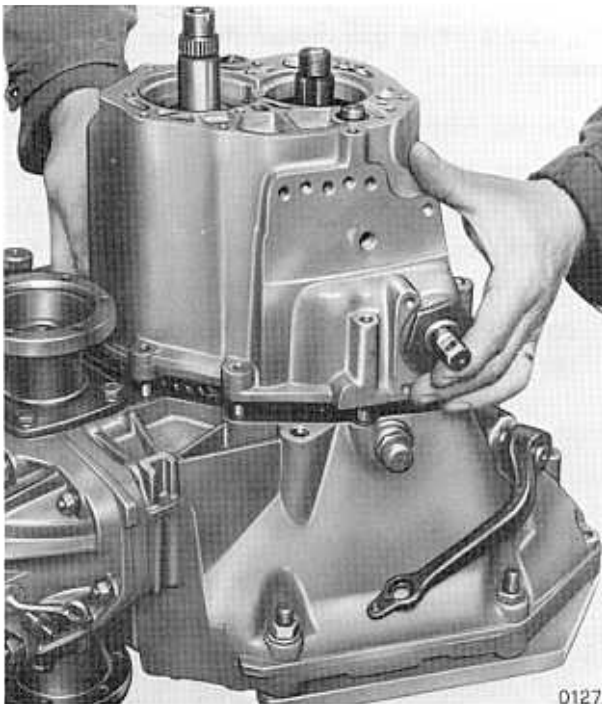

Fig. 03 3/5 - Removal of gearbox casing

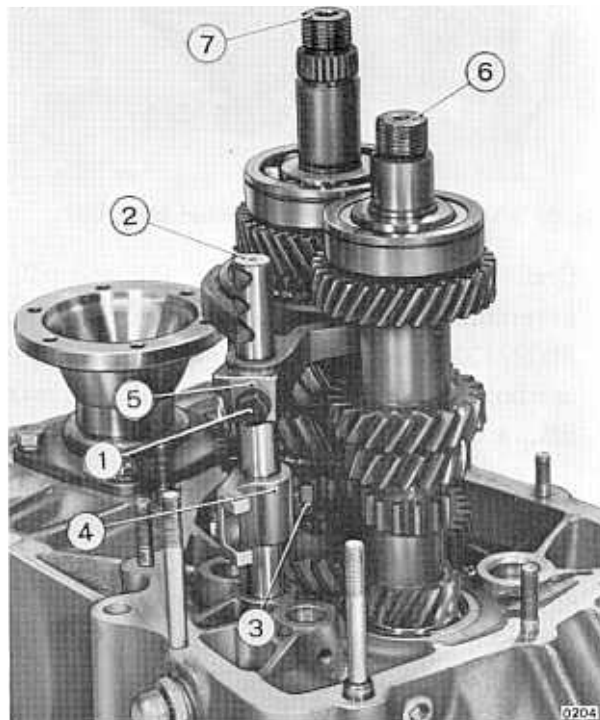

Fig. 03 3/7 Disassembly of 3rd and 4th gear selector rod

- Unscrew bolt (1) and slide off the rod (2). Remove the fork (3), shaft (4) and gear (5). Unscrew bolts (6) and slide off rod (7). Engage second gear to allow the fork (8) to slide off.

- Unscrew bolt (1) and turn rod (2) to enable bolt (3) to be unscrewed more easily. Remove rod (2) from the dog (4) and fork (5). Make sure that the retainer (ref. 2 in fig. 3/8 below) does not get lost.
- Slide off the main shaft (6) and driven shaft (7) together.

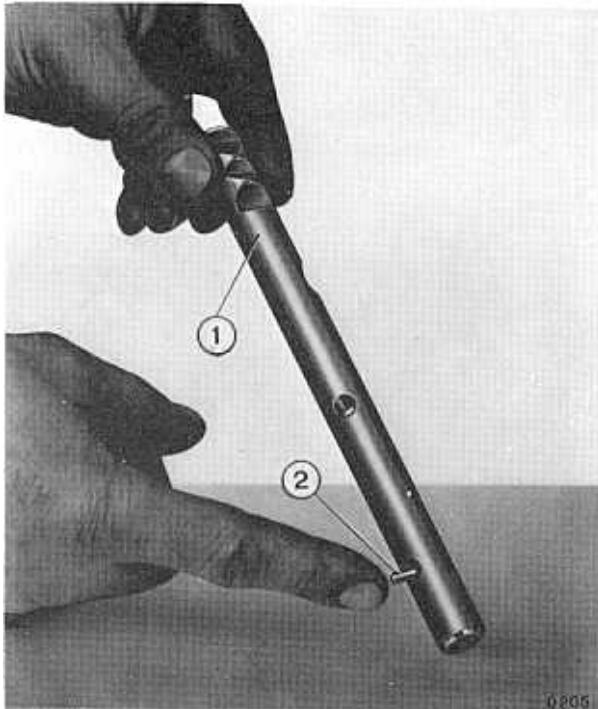

Fig. 03 3/8 - Retainer on 3rd and 4th gear selector rod

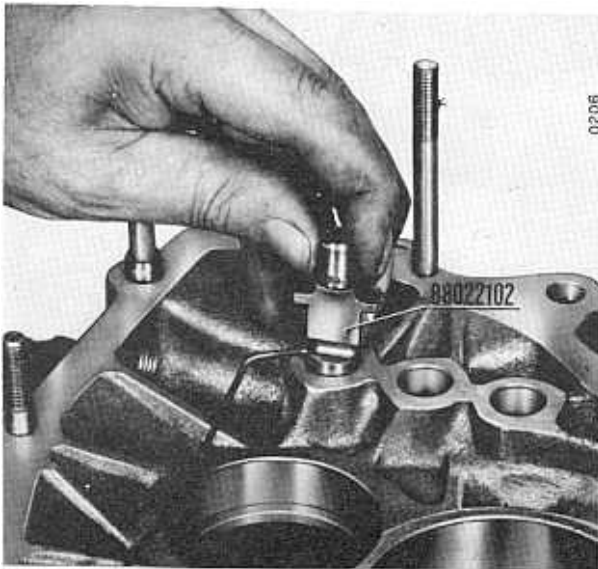

Fig. 03 3/9 - Tool 88022102 for disassembly of selector rod retainers

- Use tool 88022102 to remove the selector rod retainers
- To remove the gear selector shaft from the casing, *proceed as follows:*

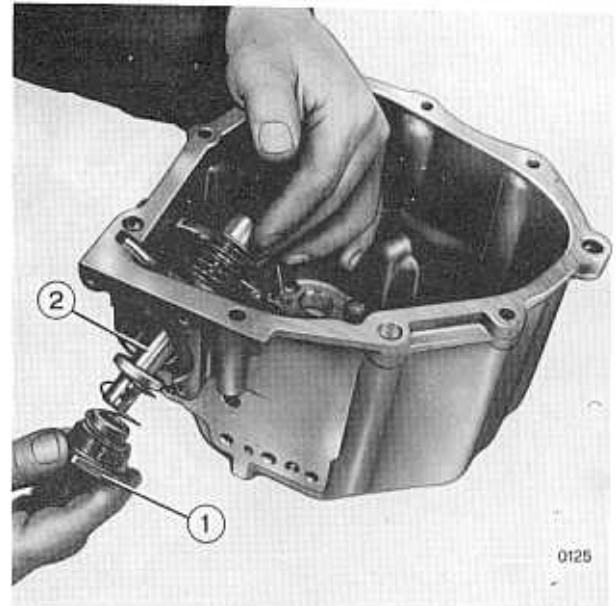

Fig. 03 3/10 - Removal or insertion of gear selector shaft from or into the gearbox casing

- Unscrew bushing (1) (released earlier) and take out the shaft in the position shown in the photo.
- To remove the oil seal from the clutch release sleeve support, *proceed as follows:*

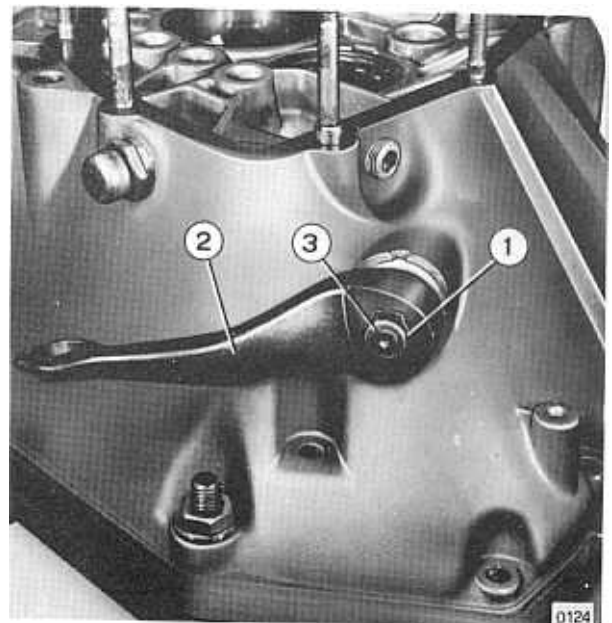

Fig. 03 3/11 - Clutch release lever and shaft.

- Use snap rings pliers to take off the seal (1) and slide off the lever (2) from the shaft (3).

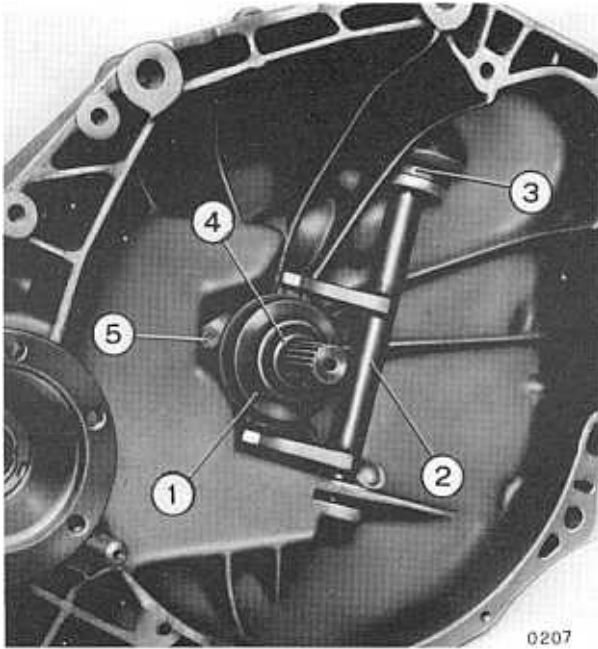

Fig. 03 3/12 - Clutch release sleeve and bearing

- Remove the shaft (2) and slide off the bearing (1). Unscrew bolts (5) and take off the support (4). Detach the oil seal from this support.

Checks

- Thoroughly clean all parts and blow dry with compressed air.
- Check all parts for wear and renew as necessary. Change all snap rings and seals (oil seals, O rings, etc.).

Reassembly

- Replace the gear selector shaft in the gearbox casing (see fig. 03 3/10) and use spanner 88021075 to remount the main and driven shafts. Check that their respective gears correspond.
- Screw up bushing (1) by hand

Note: this bushing is tightened to the correct torque loading when the casing is mounted on the differential support.

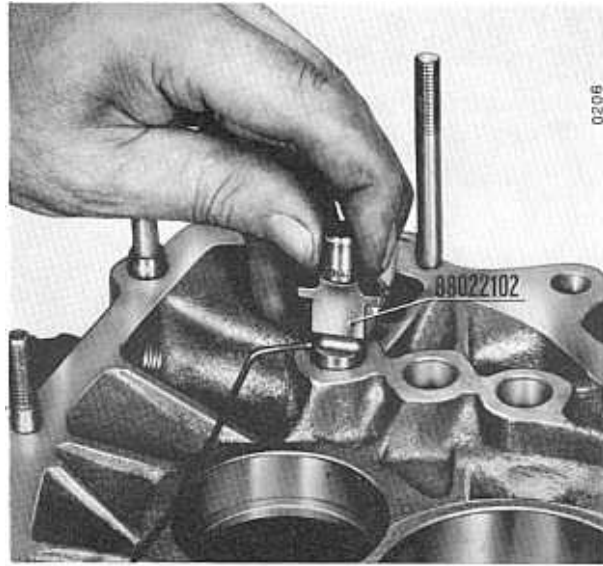

Fig. 03 3/13 - Tool 88022102 for reassembly of selector rod retainers

- Grease the retainer seatings and use tool 88022102 to reinsert the retainers.

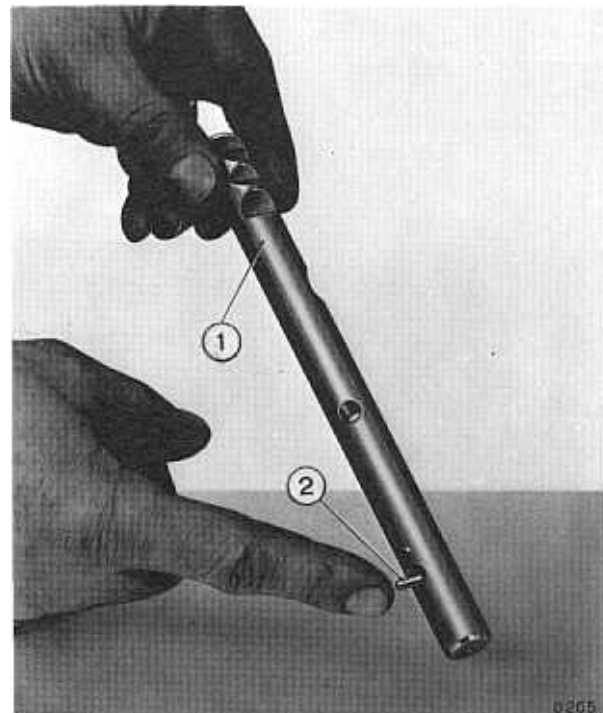

Fig. 03 3/14 - Retainer on 3rd and 4th gear selector rod

- Grease retainer (2) and place in the seating (1). Slide dog (4) and fork (5) into the rod. Return the rod (retainer side) into its own seating on the support and tighten bolts (3) and (1) to the correct torque loading.

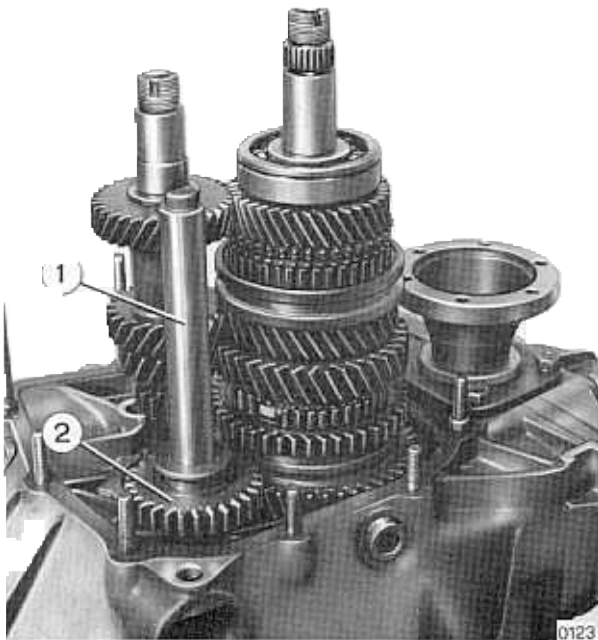

Fig. 03 3/15 Positioning of reverse gear selector rod and gear

- Lubricate shaft (1) and remount gear (2) with its teeth lead upwards. Insert the O-ring into the bottom groove and partly fit it into its own seating on the support.
- Position fork (3) and rod (2). Tighten bolt (1).
- Engage 2nd gear by means of the sliding sleeve and position fork (8). To engage rod

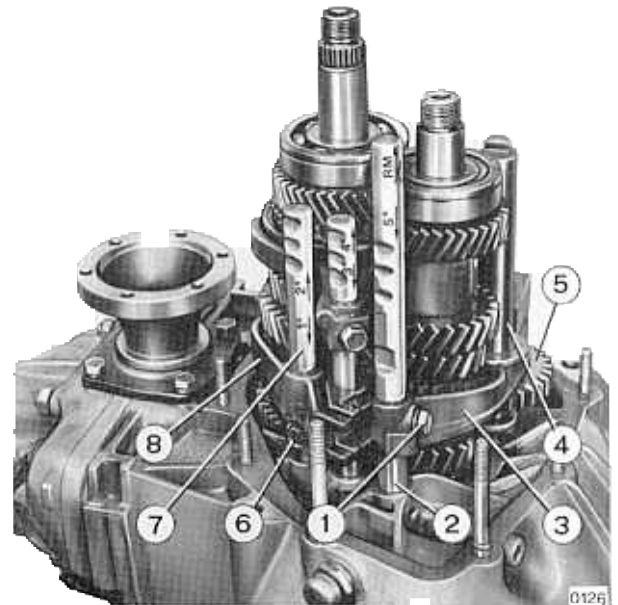

Fig. 03 3/16 - Gear control rods and reverse gear shaft

(7) in its seating, the other two rods must be brought to the neutral position to make sure that the retainers do not prevent the entry of the third rod.

Tighten bolt (6) to the correct torque loading and disengage 2nd gear to make it easier to insert the gear selector into the locks later.

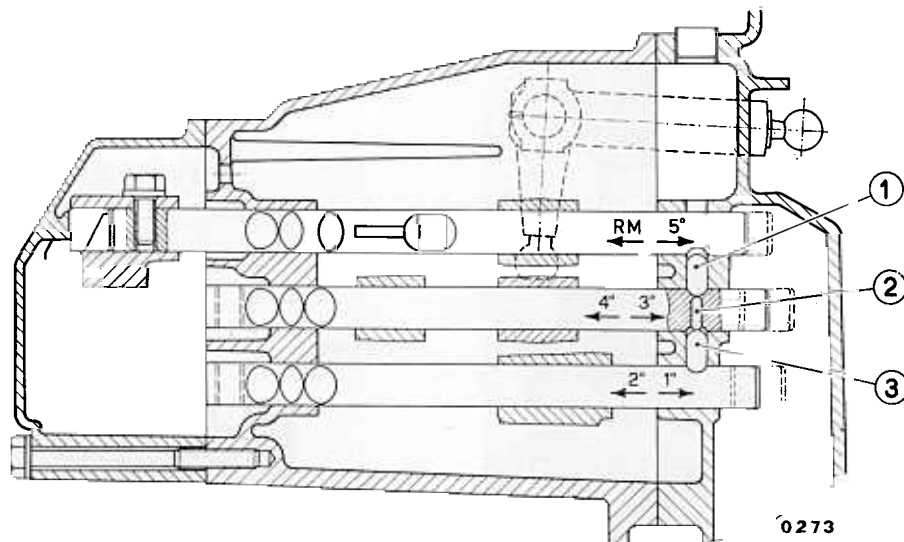

Fig. 03 3/17 - Selector rods and retainers

- (1) 5th gear and reverse gear selector rod retainer
 - (2) 3rd and 4th gear selector rod retainer
 - (3) 1st and 2nd gear selector rod retainer.
- Position the gasket and remount the gearbox casing in the reverse order. Fit the tip of the gear selector shaft in the locks and tighten nuts (ref. 10 in fig. 3/18 below) to the correct torque loading.

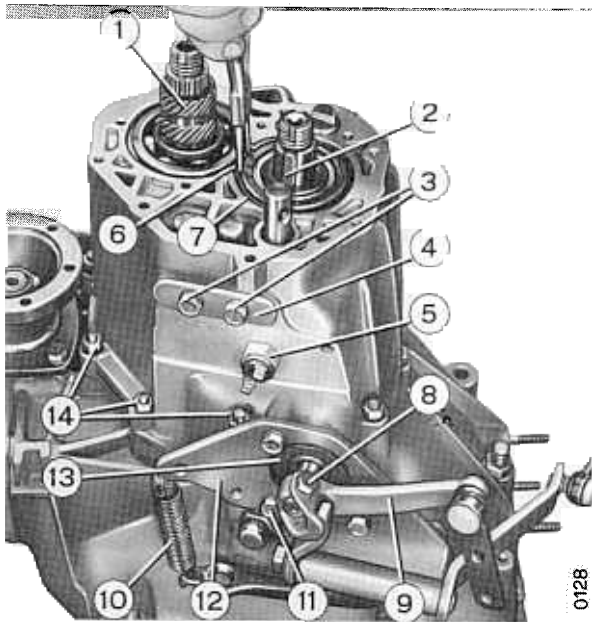

Fig. 03 3/18 - Reassembly of gearbox casing

- Grease the rod release balls and springs and remount them in their seatings. Place the gasket on the cover 4 and tighten bolts 3 to the correct torque loading.

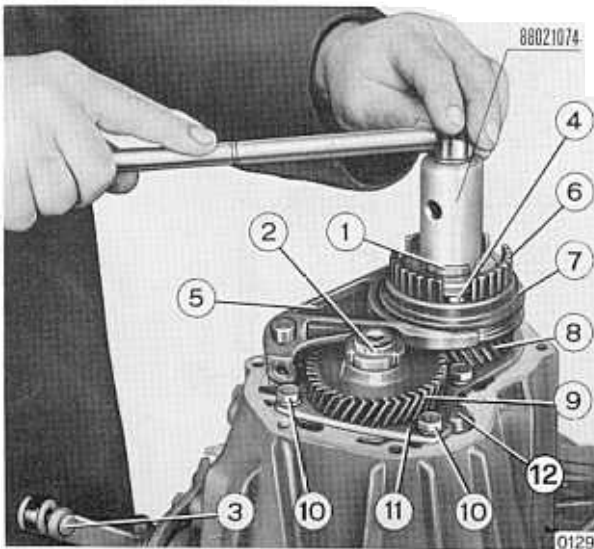

Fig. 03 3/19 - Fifth gear engaged (fork and selector rod released)

- Remount the backing light switch, snap rings 6 and 7, and key 2.
- Position plate 11 and reverse shaft 12 as shown. Remount the main and driven shafts at the same time, together with the gear 9 and the assembly consisting of the inside bushing, gear 6, synchroniser, sleeve 7, hub 8 and fork 5.
- Position the pawls, springs and rollers. Mount the cover and engage 5th gear and any other forward gear. Then use spanner 88021074 and torque spanner 88091137 to tighten ring nuts 1 and 2 to the correct torque loading.

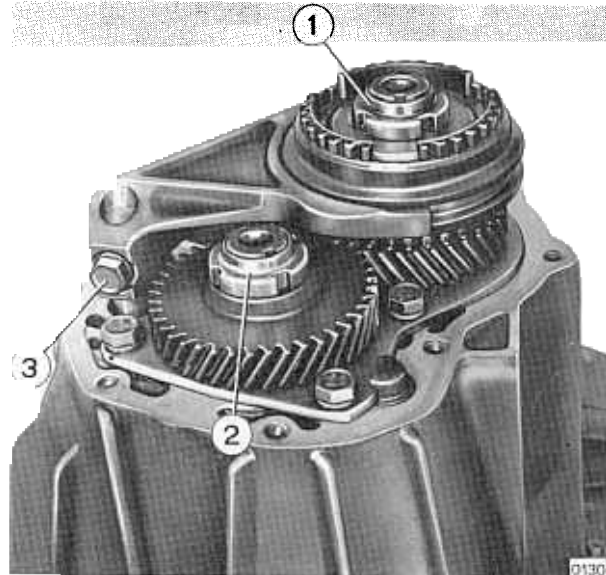

Fig. 03 3/20 - Fifth gear gears and controls

- Crimp ring nuts 1 and 2, bring the 5th gear to the neutral position, and tighten them to the correct torque loading.

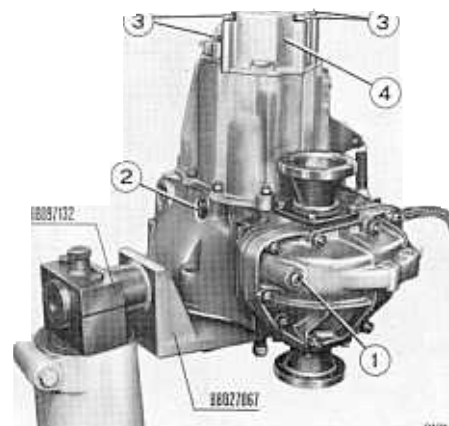

Fig. 03 3/2 - Gearbox mounted on stand 88027067

Note: Do not attempt to insert the reverse gear with the gearbox cover off, as this will allow the rollers, springs and pawls to come out of their housings.

- Place the gasket on the gearbox casing and remount the cover 4. Tighten bolts 3 to the correct torque loading.

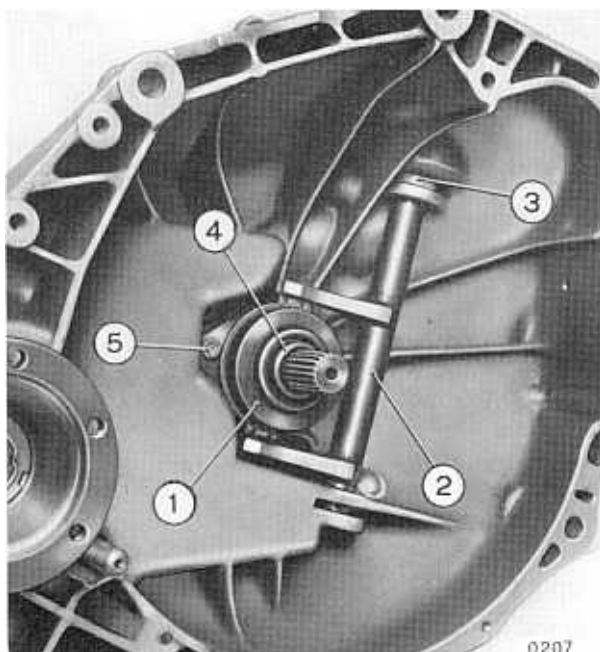

Fig. 03 3/22 - Clutch release sleeve and bearing

- Turn the assembly to bring the gearbox casing upside down.
- Use driver 88022080 to insert the oil seal on support 4, then reassemble in the reverse order. Tighten bolts 5 to the correct torque loading.
- Remove the assembly from the stand and top up the oil to the correct level.

TOOLS REQUIRED

- 88027067 - Stand
- 88097132 - Fitting for stand
- 88097130 - Column
- 88021074 - Spanner for ring nuts
- 88021075 - Spanner for gear selector bushing
- 88022102 - Tool for assembly of selector rod retainers

- 88091135 - Torque spanners
- 88091137 - Torque spanners
- 88022080 - Driver

§ 03 3 0400

OVERHAUL OF SYNCHRONISERS AND RENEWAL OF BEARINGS AND DRIVEN SHAFT PARTS IF NECESSARY

Disassemble as described in para. 03 3 0100 and *proceed as follows:*

Disassembly

- Use lead jaws to hold the driven shaft in a vice

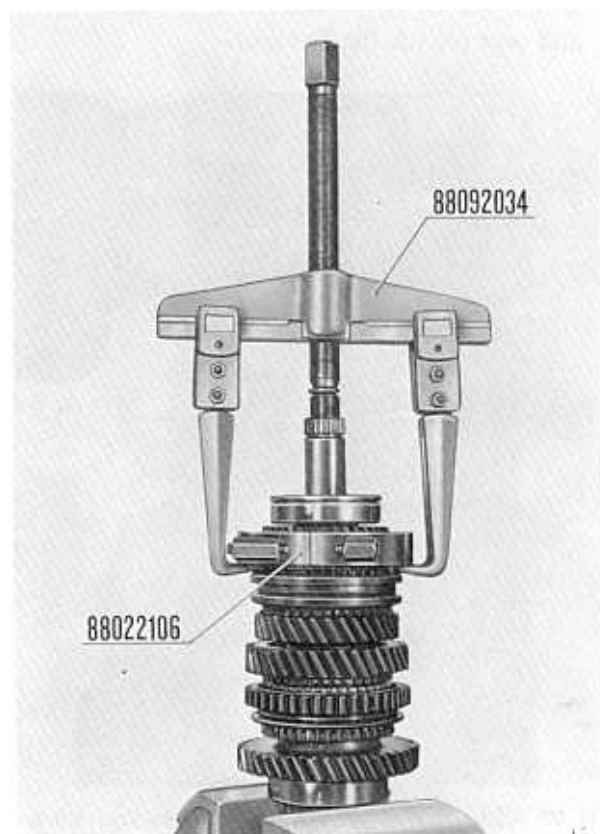

Fig. 03 2/23 - Extraction of driven shaft rear bearing

- Slide off bearing (1) and gear (2) of the 4th gear with the aid of half-rings 88022106 and puller 88092034.

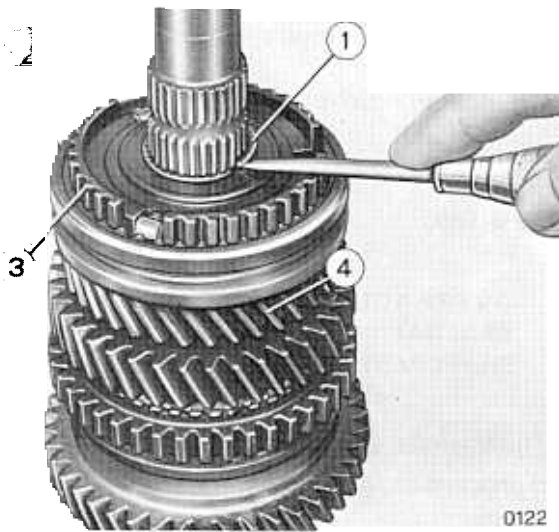

Fig. 03 3/24 - 3rd gear hub circlip

- Remove circlip (1) and slide off assembly consisting of sleeve (2), hub (3), synchroniser and gear (4) for the 3rd gear.

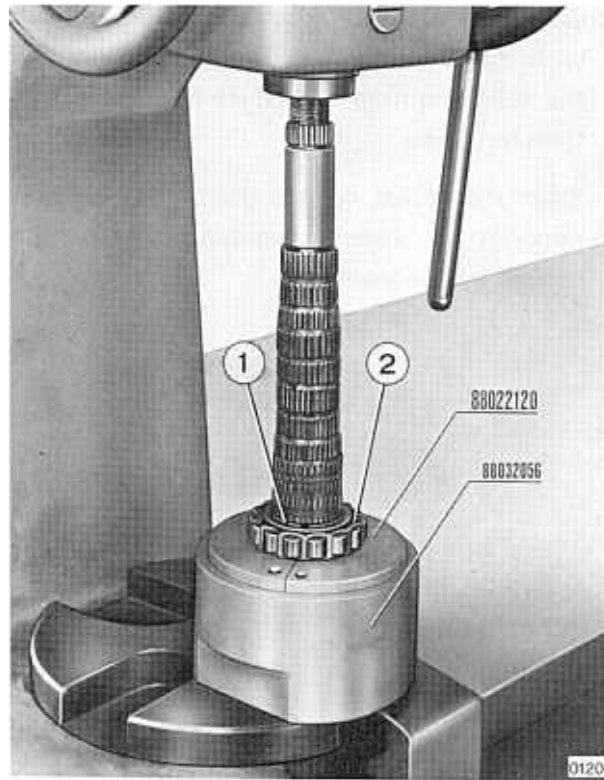

Fig. 03 3/26 - Extraction of front bearing

- Remove circlip (1), use half-rings 88022120 on base 88032056 to extract the bearing on a press.

Overhaul and checks

- Clean all disassembled parts thoroughly
- Check the sleeves and hubs for wear (particularly the teeth) and renew all parts as required. Check the coupling of the synchronisers on their gears in accordance with the distance K shown in fig. 3/27.

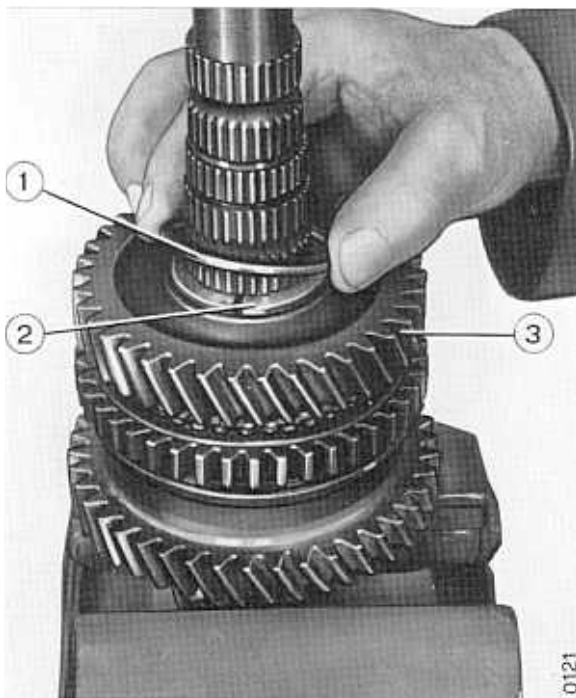

Fig. 03 3/26 - Half-thrust washers between 2nd and 3rd gears.

Remove circlip (1), slide off the half-thrust washers (2) and remove the 2nd-gear wheel.

- Remove the circlip and proceed to take off the 1st gear sleeve, hub, synchroniser and gear assembly.

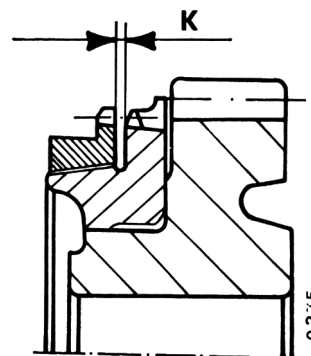

Fig. 03 2/27 - Synchroniser distance

Reassembly

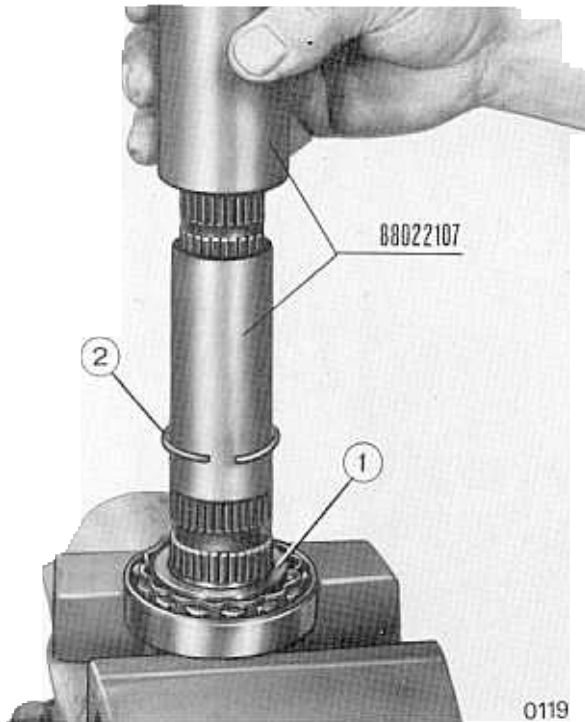

Fig. 03 3/28 - Replacing front bearing circlip with installer 88022107

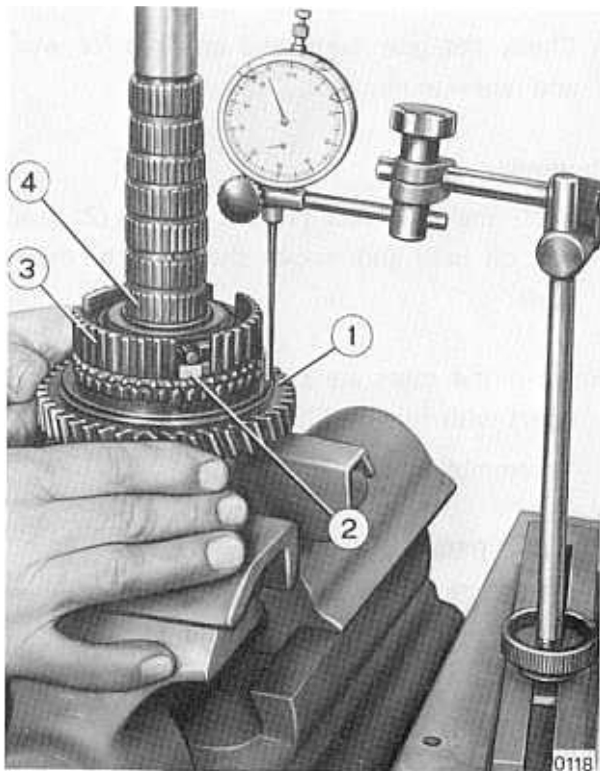

Fig. 03 3/29 - Checking the 1st-gear gear end float

- Heat bearing (1) in an 80°C oil bath and mount it on the driver shaft. Use tool 88022107 to instal the circlip (2) in its seating.

Note: if the bearing cages are plastic, do not heat, but insert with tool 88022089.

- Insert 1st-gear gear wheel (1) complete with synchroniser circlip (2) and hub (3). As previously, use installer 88022108 to position the circlip (4). Check that the end float of the 4th-gear gear wheel complies with the value given in DT-Beta Montecarlo 03/0020.

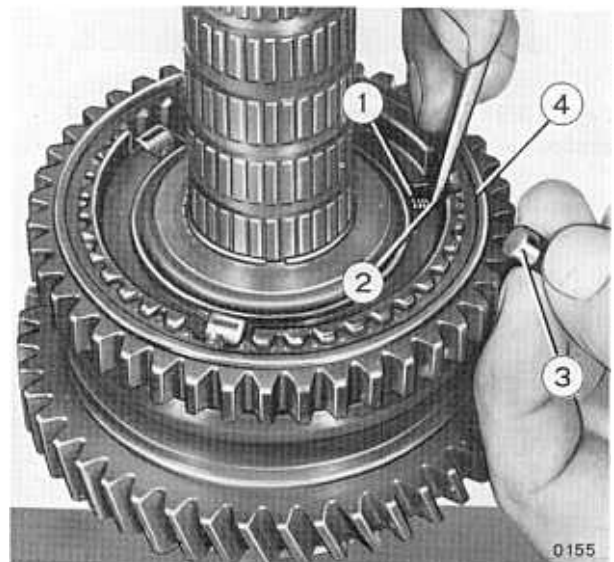

Fig. 03 3/30 - Remounting the release rollers

- Remount the sleeve (4) with the fork groove downwards. Then position the springs (1), pawls (2) and rollers (3).
- Remount the 2nd-gear gear wheel (3) complete with synchroniser, then the half-thrust washers (2) and snap ring (1). Check the end float value against DT sheet 03/0020.
- Remount 3rd-gear gear wheel complete with synchroniser and hub. Use tool 88022109 to instal the circlip and check the end float.
- Remount the sliding sleeve. As previously, insert the springs, pawls and rollers. Then remount the 4th-gear gear wheel and its

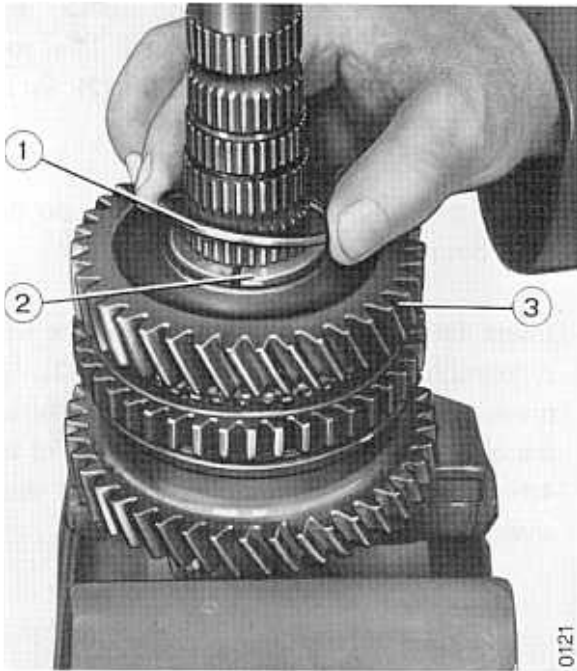

Fig. 03 3/31 - Remounting 2nd-gear gear wheel and circlips

synchroniser.

- Heat the rear bearing in an 80°C oil bath and mount it. Check the 4th gear end float.
- Reassemble as described in para. 03 3 0100.

TOOLS REQUIRED

- 88022106 - Half-rings for extraction of driven shaft rear bearing
- 88092034 - Extractor
- 88022120 - Half-rings for extraction of driven shaft front bearing
- 88032056 - Base for half-rings
- 88022107 - Installer for driven shaft front bearing circlip
- 88022089 - Installer for driven shaft front bearing
- 88022108 - Installer for driven shaft 1st and 2nd gear circlip
- 88022109 - Installer for driven shaft 3rd and 4th gear circlip

§ 03 3 0700

RENEWAL OF MAIN SHAFT OR ITS BEARINGS

Disassemble as described in para 03 3 0100

and proceed as follows:

Disassembly

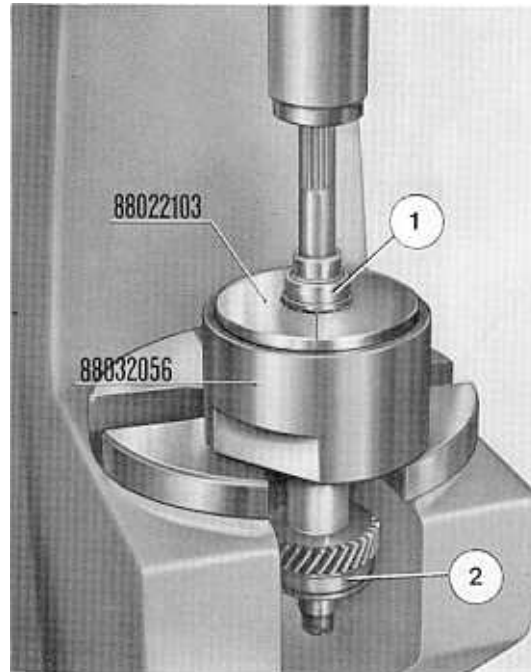

Fig. 03 3/32 - Removal of inner and front bearing from main shaft

Use half-rings 88022103 and 88022105 together with base 88032056 to drive off the inner race (1) and front bearing (2) on a press. Check the gear teeth and bearings for wear and renew as required.

Reassembly

- Heat the inner race (1) and bearing (2) in an 80°C oil bath and mount them on the main shaft.

Note: if the cages are plastic, do not heat, but insert with tool 88062503 (7th modification)

- Reassemble as described in para 03 3 0100.

TOOLS REQUIRED

- 88022103 - Half-rings for extraction of inner race of main shaft front bearing
- 88022105 - Half-rings for extraction of inner race of main shaft rear bearing
- 88032056 - Base for half-rings
- 88062503 - Installer for main shaft bearings (7th modification)

§ 03 3 1000

OVERHAUL OF THE DIFFERENTIAL

Disassemble as described in para 03 3 0100 and *proceed as follows:*

Disassembly

- Uncrimp the flange attachment ring nuts

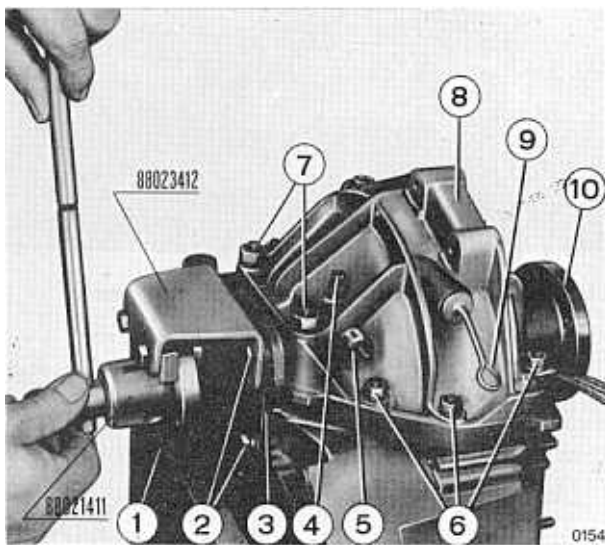

Fig. 03 3/33 - Release of flange attachment ring nuts

- Apply tool 88023412, unscrew the ring nut with spanner 88021411 and remove flange (1). Unscrew bolts (2) and remove the cover (3) and shim. Remove the opposite flange and cover (10) in the same way.
- Unscrew bolt (4) and slide off the speedometer gear (5).
- Unscrew nuts (6) and (7) and tap the cover (8) with a mallet to free it. Take off the cover and the differential unit.

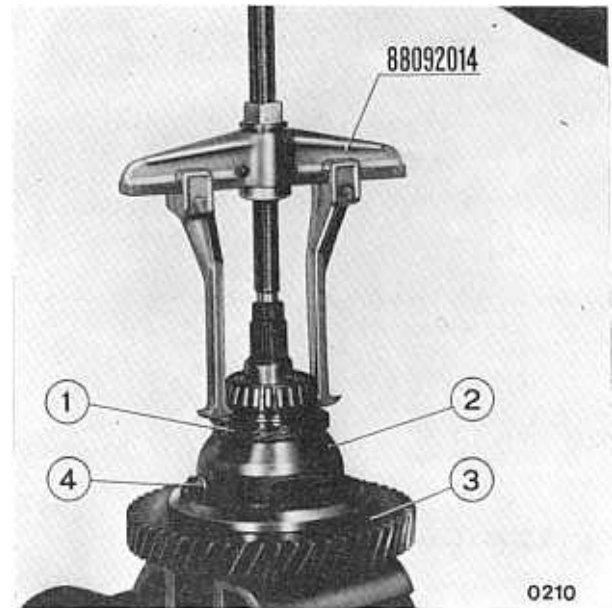

Fig. 03 3/34 - Removal of differential bearings

- Place the differential in a vice with lead jaws and use extractor 88092014 to remove the bearings.

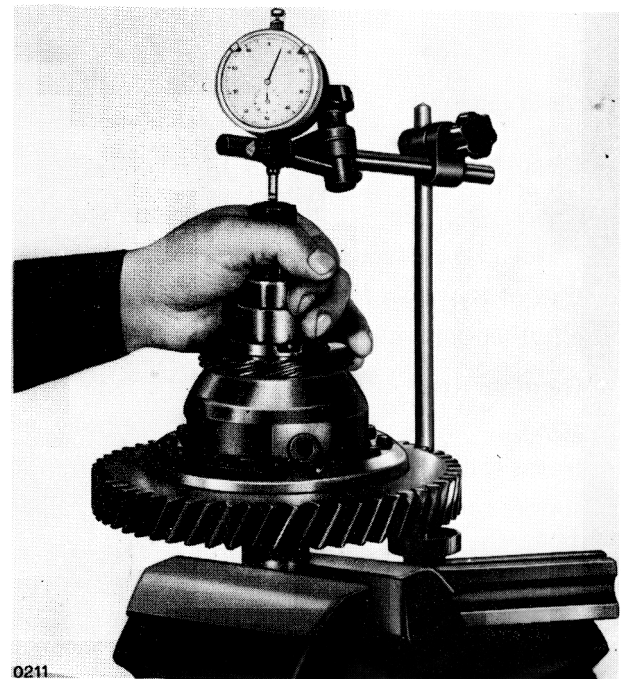

Fig. 03 3/35 - Checking end float between side gear and pinion

- Before disassembling the differential, check that the end float between the side gears and pinions is within the prescribed limits.
- Clamp the spur gear in a vice and unscrew the bolts joining the two half-casings.

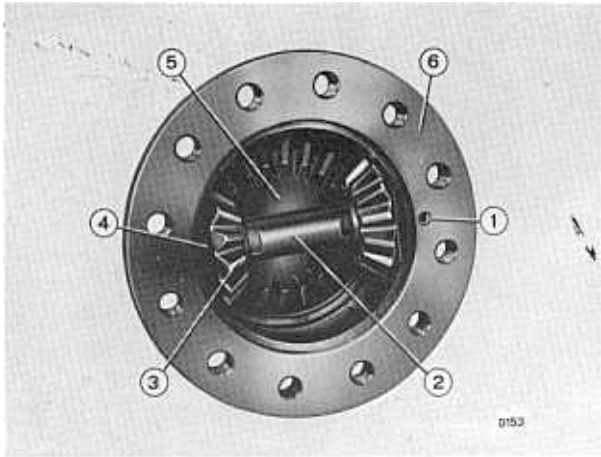

Fig. 03 3/36 - Disassembly of side pinions.

- Remove pin (1) and slide off shaft (2). Take off the side pinions (3) with their thrust pieces and the side gear (5) with its thrust ring.
- If the spur gear has to be renewed, extract it from its half-casing with a mallet.

Overhaul and checks

- Clean all disassembled parts thoroughly.
- Check the gear teeth for wear or spalling. Check the surface of the side pinion shaft and that of the gears for damage or wear. Examine all other parts carefully.
- Remove the oil seals from the side gear covers, renew the O-rings and remove all traces of "Blue Stop" from the differential support and the cover.

Reassembly

Remount the side gear and pinions on each half-casing in the reverse order. Remount the spur gear on the second half-casing, remembering that the mating surface between these two parts is denoted by a small machining undercut on the inside circumference of the spur gear (ref. 1 in fig. 03 3/37).



Fig. 03 3/37 - Remounting spur gear on half-casing

- Lock the half-casings with three bolts set at 120° from each other. Recheck the end float as before and, if necessary, take up excess play with thrust rings.
- Heat the bearing inner races in an 80°C oil bath and remount them on the differential. Then mount the outer races.
- Place the differential on the support, smear "Blue Stop" on the support-to-cover mating surfaces and then tighten the nuts to the correct torque loading.

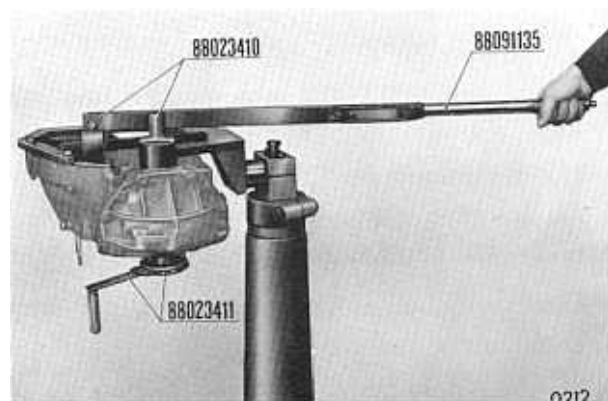

Fig. 03 3/38 - Bedding of differential taper bearing outer races.

- Bring the gearbox side of the unit to the top, mount the oil seal cover without the oil seal, and tighten the respective mounting bolts. Fit tool 88023411 to the side gear, check that there is no end float between the gear and the pinion, and tighten the tool with the flange attachment ring nut.
- Turn the assembly through 180°C and fit tool 88023410 for bedding the outer races. Apply torque spanner 88091135 (set to the correct loading) to the arm of the tool. If this spanner is not available, use a weight equal to the value shown in the relevant SAT sheet. Turn the handle of the tool and bed the bearings.

0.10 = 2.5 mm.

- Fit a shim of the correct thickness and replace the cover without the oil seal. Tighten the mounting bolts to the correct torque loading.

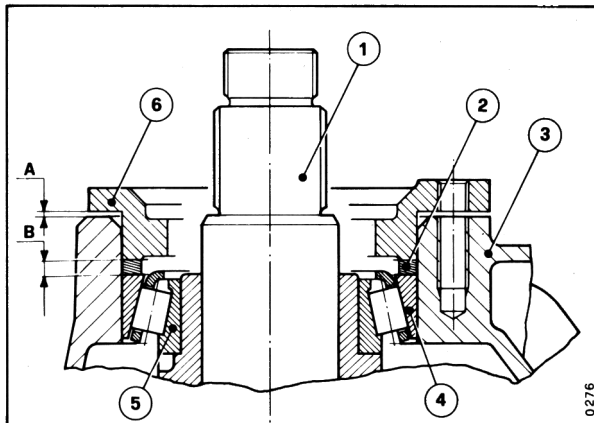

Fig. 03 3/39 - Assessment of shim thickness to preload the bearings.

1. Side gear - 2. Shim of known thickness - 3. Differential support - 4. Outer race - 5. Inner race - 6. Oil seal cover

- Remove tool 88023410 and mount a shim of known thickness on the bearing (preferably the thickest spare shim). Place the cover (6) over the shim and use a feeler gauge to measure the gap between the cover and the support. The difference between the known value and the measured value will be that of the shim required to preload the bearing.

Example:

B = Thickness of shim mounted (2.6 mm)

A = Gap to be measured with feeler gauge

S = Thickness of shim required

- If A is between 0.10 and 0.15 (i.e. feeler 0.10 mm passes and feeler 0.15 mm does not), the smaller value is taken, so that S will be 2.60 –

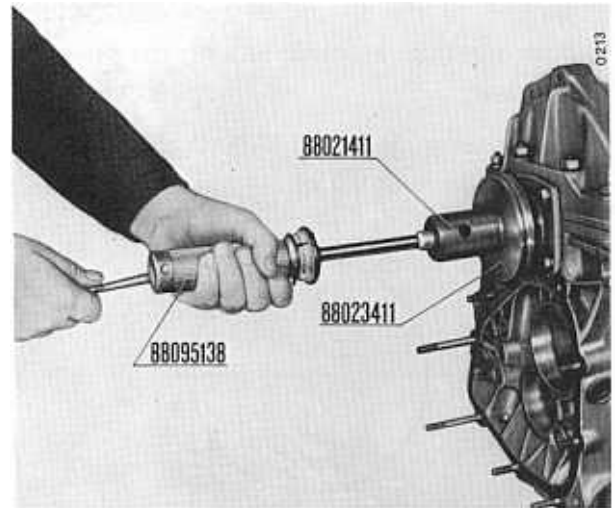

Fig. 03 3/40 - Measurement of rolling torque of differential bearings with a torque spanner.

- Turn the assembly, remove the handle of tool 88023411 and use torque meter 88095138 together with socket 88021411 to measure the rolling torque of the bearing. Since the

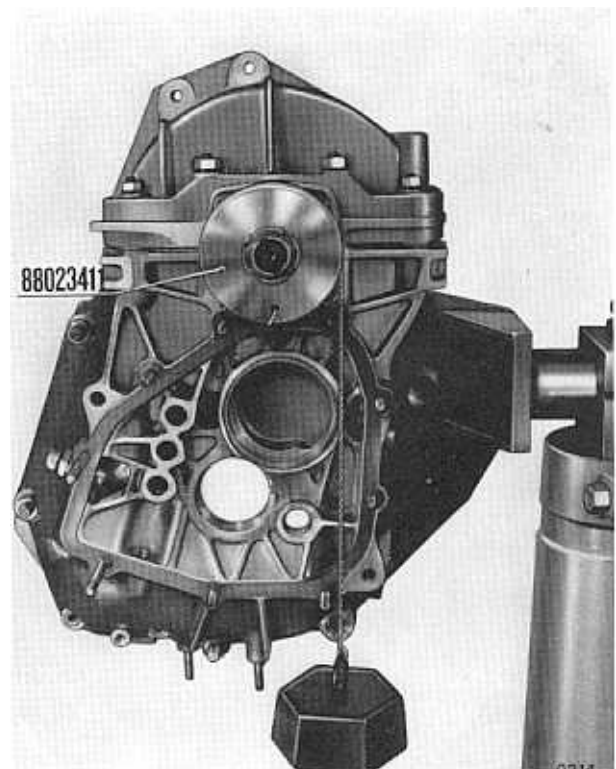

Fig. 03 3/41 - Measurement of rolling torque with the aid of weights.

scale of the meter is in cm/kg, the figure 10 on the instrument corresponds to 0.1 metre per kg.

If the rolling torque is known and a torque meter is not available, the weight to be applied to the sheave of tool 88023411 is determined in accordance with the following example:

Rolling torque value 0.147 N·(0.150 mkg)

Sheave diameter 0.1 m

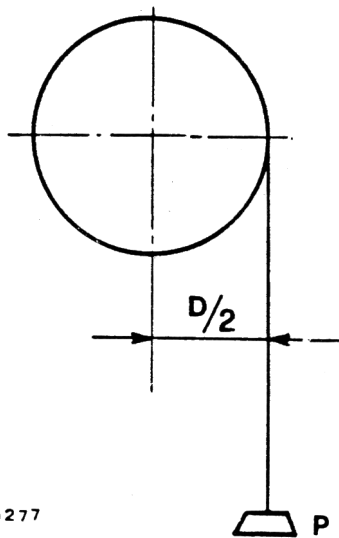

0277

Fig.03 2/42 - Calculation of weight to be applied.

$$P = \frac{0.147}{0.05} = 2.94 \text{ N (3 Kg)}$$

- Weight values are also given on the SAT sheets
- If the rolling torque value is not correct, rectify with shims as described.
- Dismount the oil seal covers and insert new seals with tool 88012161 on a press.
- Remount the covers and their O-rings and tighten the bolts to the correct torque loading
- Remount the differential flange and partly tighten the ring nuts. Use tool 880412 and socket 88021411 to tighten them to their correct torque loading. Crimp the ring nuts. Reassemble as described in para 03 3 0100

TOOLS REQUIRED

- 88023412 - Tool to hold differential flange
- 88092014 - Puller for differential bearings
- 88023410 - Tool for bedding differential bearing outer races
- 88091134
- 88091135 - Torque spanners
- 88091137
- 88023411 - Tool to rotate and check preloading of differential bearings
- 88095138 - Torque meter to measure rolling torque
- 88012161 - Oil seal driver

CHAPTER 2

GROUP-CHANGE

§ 03 2 2500

REMOVING AND REFITTING THE GEARBOX-DIFFERENTIAL UNIT

Stand the vehicle over the pit, fit covers 88083051 and *proceed as follows*:

Removal

From above the vehicle:

- Remove the battery positive lead.

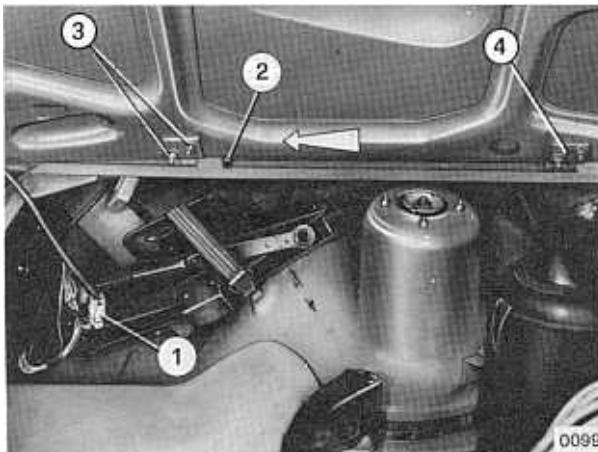

Fig. 03 2/1 - Removal of bonnet

- Remove the spare wheel and its heat shield
- Disconnect the cylinder (1), undo the nut (2) and slide off the bonnet in the direction of the arrow.

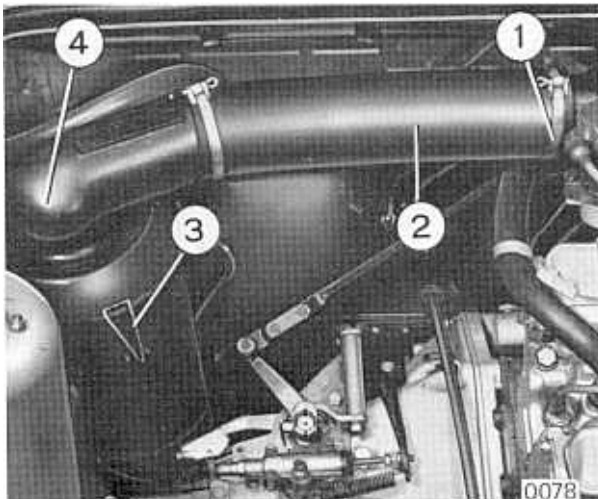

Fig. 03 2/2 - Removal of mileage counter

- Slacken the clamp (1) and take off the cover (2), complete with the filter. Then remove the filter body (3).

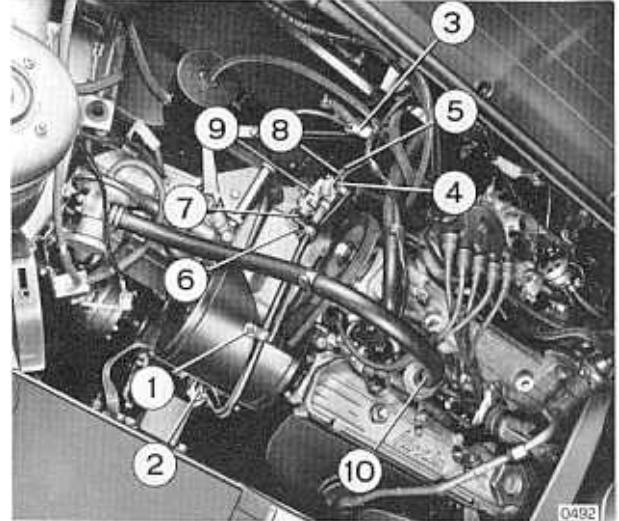

Fig. 03 2/3 - Removal of mileage counter

- Unscrew bolt (1) and disconnect the control (2).
- Undo the connection (3), unscrew bolt (4) and take off the lead (5). Undo bolt (6) and collect the plate (7). Then unscrew the ring nut (8) and take off the counter (9).
- Remove hose (10).
- Take off the air pump as described at para. 01 2 0720 of the Scorpion variant.

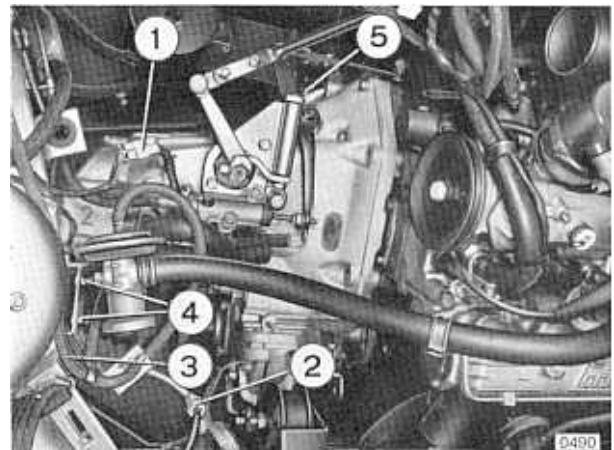

Fig. 03 2/4 - Removal of valve assembly

- Undo connections (1, 2), slide off pipe (3). Unscrew nuts (4) and remove the complete valve assembly.

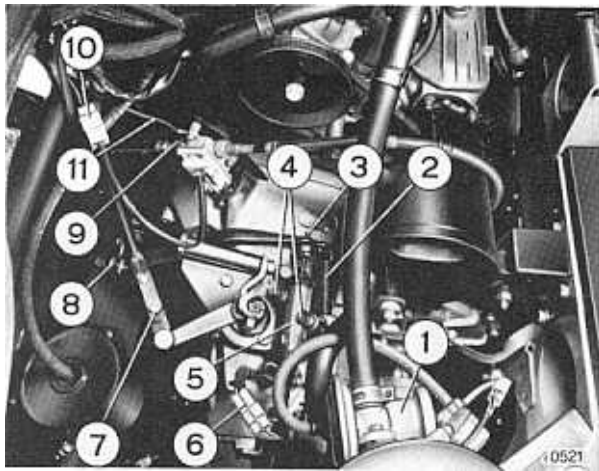

Fig. 03 2/5 - Gearbox control linkage

- Remove gearshift and selector rods (1 e 2)
- Detach the spring (3), take out the split pin (4), unscrew bolts (5) and take off the cylinder (6).
- Disconnect the cylinder (7) and take off the lead (8).
- Undo bolt (9) and collect the plate (10)
- Undo bolt (5) (see fig. 03 2/4).
- Slacken the bolts holding the left rear wheel.

From below the vehicle

- Raise the back of the vehicle and place it on trestles. Take off the left rear wheel.

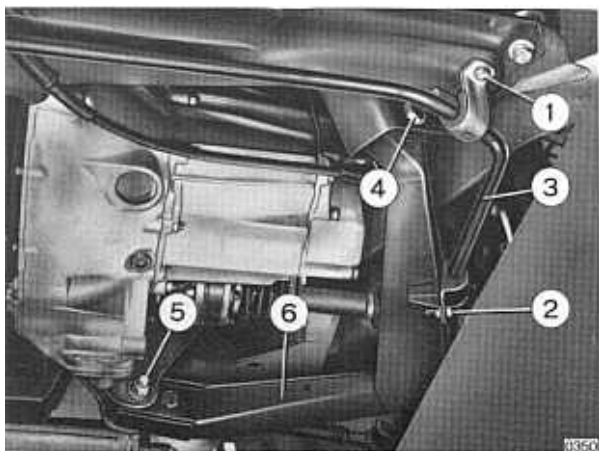

Fig. 03 2/6 - Removal of arm and rear torsion bar

- Detach the right and left half-shafts from the differential flange.
- Remove the hand brake cable sheath from the arm

- Undo bolts (1) and (2). Take off the torsion bar (3) (left side- only). Then undo bolts (4) and (5) and remove the arm (6).

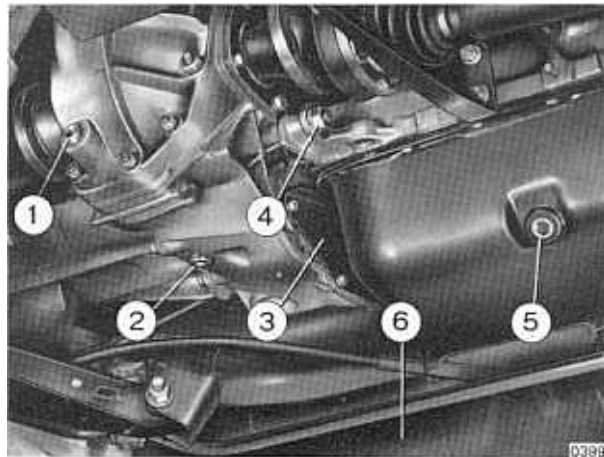

Fig. 03 2/7 - View of dust guards

- Remove guards (1) and (2). Undo nut (3)



Fig. 03 2/8 - Cradle 88027069 used to support engine.

- Arrange engine support cradle as shown in the photo.
- Remove the starter motor as described at para 14.2.6900 (Montecarlo Manual).

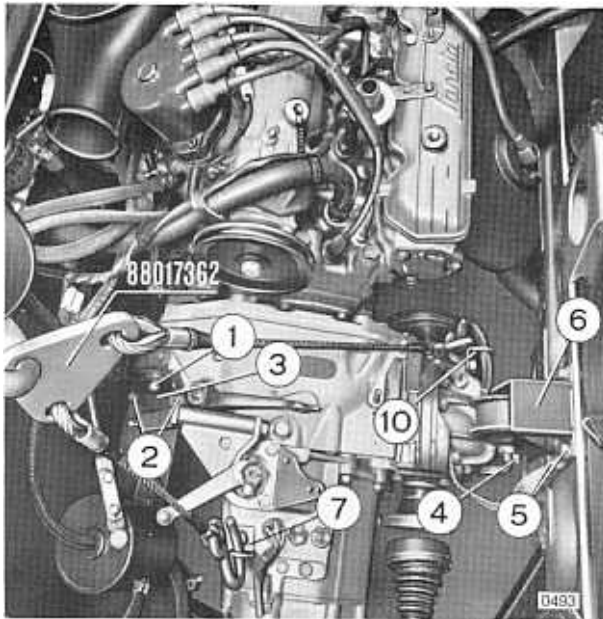

Fig. 03 2/9 - Application of engine lifting hook 88017362

- Set plates (7) and (10) as shown in the photo (see reference numbers (7) and (10) in figs. 03 2/2 & 2/4). Apply hook 88017362 and take up the slack.

- Undo and remove bolt (1), unscrew bolts (2) and take off the mounting (3). Undo bolts (4) and bolts (5). Remove mounting (6).
- Shift the gearbox and differential unit backwards as required and take it out from below the vehicle. The assistance of another mechanic will be required to prevent the gearbox from knocking the arm (detached previously).
- Remove the metal sheet between the gearbox and the engine.

Refitting

- Refit the gearbox in the reverse order and tighten all nuts and bolts to the correct torque loadings, remembering that this must be done with the vehicle at its static load in the case of the rear left arm attachment bolts.

TOOLS REQUIRED

- 88027069 - Engine support cradle
- 88017362 - Engine lifting hook

BASIC TYPE

The directions and operations refer to the transmission fitted to all car models.

TRANSMISSION GROUP CONTENTS

CHAPTER 1

Troubles, probable causes, checkings and operations to be carried out page 04 1/1

CHAPTER 2

§ 04 2 0100	Removal and refitting a front wheel drive shaft	page 04 2/1
§ 04 2 0120	Renewal of a constant velocity joint dust guard	" 04 2/1
§ 04 2 1000	Removal and refitting a shaft with flange and joint on the wheel side	" 04 2/2

FAULT	PROBABLE CAUSES	CHECKS ADVISABLE BEFORE REPAIRING	ACTION NECESSARY	PARA
Noisy transmission	Lack of lubrication due to breakage of constant velocity joint guard and escape of grease	-	Removal and refitting of drive shaft	04 2 0100

CHAPTER 2

§ 04 2 0100

REMOVAL AND REFITTING OF A FRONT WHEEL DRIVE SHAFT

Stand the vehicle over the pit, fit covers 88083051 and *proceed as follows*:

Removal

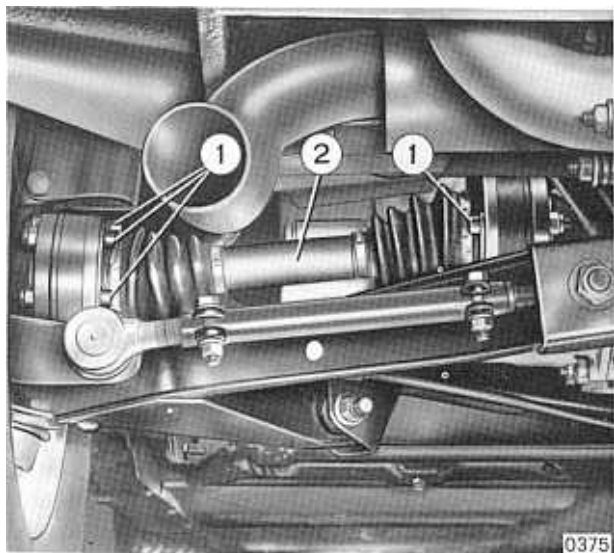

Fig. 04 2/1 - Left hand drive shaft

From below the vehicle:

- Lift the back of the vehicle, unscrew bolts (1) and remove the drive shaft (2).
- Before removing the right hand shaft, detach the bracket holding the exhaust pipe to the underbody.

Refitting

- Reassemble in the reverse order and tighten the bolts to their correct torque loading.

§ 04 2 0120

RENEWAL OF A CONSTANT VELOCITY JOINT DUST GUARD

Stand the vehicle over the pit, fit covers 88083051 and *proceed as follows*:

Removal

From below the vehicle:

- Raise the back of the vehicle, unscrew the mounting bolts and take off the drive side joint.
- Remove the two clips holding the rubber guard.
- Take off the joint retaining circlip. Slip the joint from the shaft and remove the guard, complete with its sleeve.

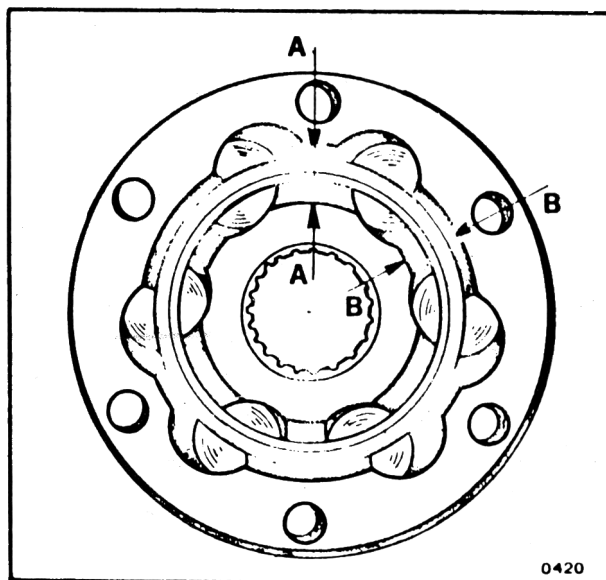

Fig. 04 2/2 - Constant velocity joint

Refitting

Note: if the balls slip out of their seatings when the joint is removed from the shaft, refer to fig. 04 2/2 when replacing. "A", in fact, must coincide with "A". If it coincides with "B", the joint will be locked.

The groove around the circumference of the joint must be on the flange side.

- Mount the guards on the shaft with the sleeve. Reattach the joint and add grease of the correct type.
- Refit the circlip and fix the guard by means of its clips.
- Complete the operation by reattaching the joint to the shaft and tighten to the correct torque value.

§ 04 2 0500

**REMOVAL AND REFITTING A SHAFT WITH
FLANGE AND JOINT ON THE WHEEL SIDE**

Stand the vehicle over the pit, fit covers 88083051 and *proceed as follows*:

Removal

From above the vehicle:

- Slacken the bolts holding the wheel

From below the vehicle:

- Lift the back of the vehicle and rest it on trestle 88097120.
- Unscrew the bolts holding the joint to the flange and move the joint to one side.

From above the vehicle:

- Remove the wheel.
- Uncrimp the tab of the nut holding the bearing on the wheel hub
- Apply arm 88053151 to the flange and unscrew the nut.

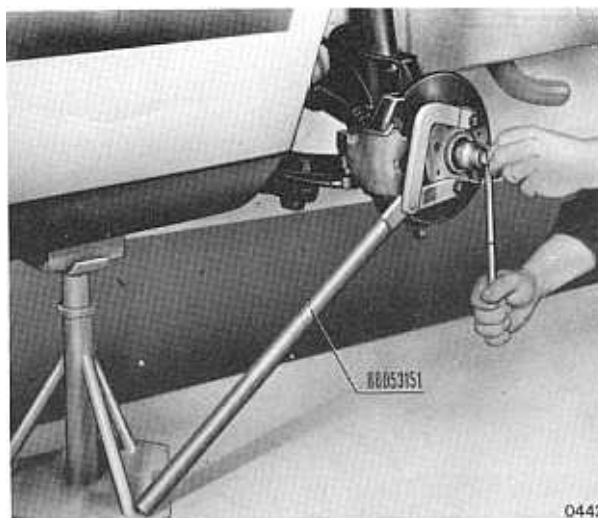

Fig. 04 2/3 - Release of bearing to-hub nut.

- Apply tool 88052009 and remove shaft with flange.

Refitting

- Reassemble in the reverse order and tighten the bolts and the nut to their correct torque loading.

SEC 05

Axle Housings

Axle housing - Step-down and differential gears

(Not Fitted to This Vehicle)

SEC 06

Axle Beams

Front and rear axle shafts and transverse reaction bar

(Not Fitted to This Vehicle)

BASIC TYPE

The directions and operations refer to the suspensions fitted to all car models.

SUSPENSION GROUP CONTENTS

CHAPTER 1

Troubles, probable causes, checkings and operations to be carried out

from page 07 1/1
to page 07 1/3

CHAPTER 2

Front Suspension

§ 07 2 0200	Removing and refitting the front suspension	page 07 2/1
§ 07 2 0700	Removing and refitting the front suspension arms	" 07 2/1
§ 07 2 0800	Renewing the ball joint of a front suspension arm	" 07 2/3
§ 07 2 0900	Renewing the front suspension arm silent blocks	" 07 2/3
§ 07 2 1100	Removing and refitting the front stabilizer bar	" 07 2/5
§ 07 2 1300	Renewing the front stabilizer bar centre and end mounting buffers	" 07 2/6
§ 07 2 1700	Removing and refitting the stabilizer bar and suspension arms from the subframe on the stand	07 2/8

Rear Suspension

§ 07 2 2000	Removing and refitting the rear suspension crossmember	07 2/11
§ 07 2 2200	Renewing the rear stabilizer bar silent blocks	07 2/12
§ 07 2 2300	Removing and refitting the rear stabilizer bar	07 2/14
§ 07 2 2310	Renewing the rear stabilizer bar end ball joint	07 2/14
§ 07 2 2400	Removing and refitting the rear suspension strut	07 2/15
§ 07 2 2600	Removing and refitting the rear suspension transverse links	07 2/17

CHAPTER 4

§ 07 4 0120	Checking a front suspension arm for alignment	page 07 4/1
§ 07 4 0900	Renewing the rear suspension transverse link silent blocks (up to car No.	" 07 4/3
§ 07 4 0910	Do. (from car No.)	" 07 4/4
§ 07 4 1000	Disassembling and reassembling the right, or left-hand front suspension	" 07 4/5
§ 07 4 1100	Disassembling and reassembling the right, or left-hand rear suspension	" 07 4/7
§ 07 4 1200	Disassembling and reassembling a front, or rear suspension strut	" 07 4/8
§ 07 4 1210	Renewing the buffer valve	" 07 4/9

FAULT	PROBABLE CAUSE	CHECKS ADVISABLE BEFORE REPAIRING	ACTION NECESSARY	PARA
Knocking front or rear suspension	Faulty shock absorbers	Check whether noise more noticeable over bad roads	Removal and refitting of front suspension Removal and refitting of rear suspension Testing the shock absorbers	07 2 0200 07 2 2400 16 4 5100
	Suspension spring fatigue	Ditto	Removal and refitting of front suspension	—
			Disassembly and reassembly of front suspension Removal and refitting of rear suspension Disassembly and reassembly of rear suspension	07 2 0200 07 4 1000 07 4 1100
	Broken or worn out pads between suspension springs and support surfaces	Check whether metallic noises due to springs hitting the support surfaces can be heard over bumpy roads.	Removal and refitting of front suspension Disassembly and reassembly of front suspension Removal and refitting of rear suspension Disassembly and reassembly of rear suspension	07 2 0200 07 4 1000 07 2 2400 07 4 1100
	Worn or crushed transverse link silent blocks	Check for noise over bad roads	Removal and refitting of rear suspension transverse links Renewal of rear suspension transverse link silent blocks	07 2 2600 —

FAULT	PROBABLE CAUSE	CHECKS ADVISABLE BEFORE REPAIRING	ACTION NECESSARY	PARA
Knocking front or rear suspension (cont'd)	Worn stabiliser bar silent blocks and buffers	Check for noise over bad roads	Renewal of front stabiliser bar centre and end buffers Removal and refitting of front stabiliser bar Renewal of rear stabiliser bar silent blocks Removal and refitting of rear stabiliser bar	07 2 1300 07 2 1100 07 2 2200 07 2 2300
Noisy or squeaky front or rear suspension	Excessive play in arm ball joints	—	Renewal of arm ball joint	—
	Damaged or worn front suspension thrust cup		Removal and refitting of front suspension Disassembly and reassembly of right or left front suspension	07 2 0200 07 4 1000

FAULT	PROBABLE CAUSE	CHECKS ADVISABLE BEFORE REPAIRING	ACTION NECESSARY	PARA
Vehicle out of trim	Front suspension arm or stabiliser bar silent blocks broken, fatigued or at incorrect torque loading	Check whether fault attributable to front suspension	Renewal of arm silent blocks Renewal of front stabiliser bar silent blocks	— 07 2 1300
	Rear suspension transverse link or stabiliser bar blocks broken, fatigued or at incorrect torque loading	Check whether fault attributable to rear suspension	Renewal of rear stabiliser silent blocks Removal and refitting of rear transverse links Renewal of rear transverse link silent blocks	07 2 2200 07 2 2600 —

CHAPTER 2

FRONT SUSPENSION

§ 07 2 0200

REMOVAL AND REFITTING OF A FRONT SUSPENSION

Stand the vehicle over the pit and *proceed as follows*:

Removal

- Loosen the stud bolts of the wheel concerned, Lift the vehicle from inside the pit with a pillar lift.



Fig. 07 2/1 - Lifting the car

- Take off the wheel and unscrew nuts (5).

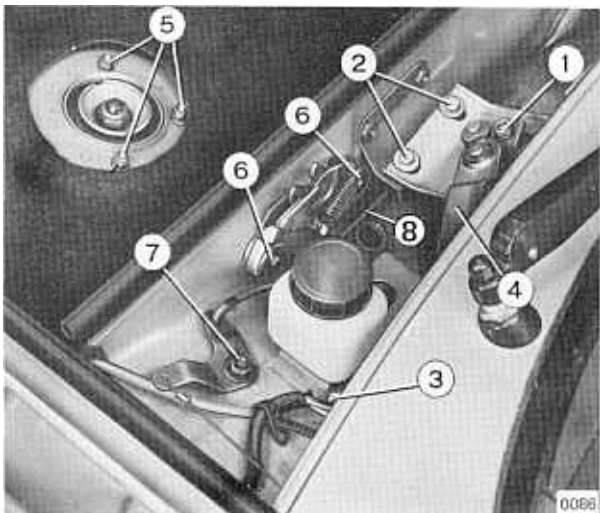

Fig. 07 2/2 - Fitting strut to body

- Unscrew parts (3) and remove the strut assembly (1) from the wheelhousing. Attach the swivel to the body to relieve the strain on the brake fluid hose (4).

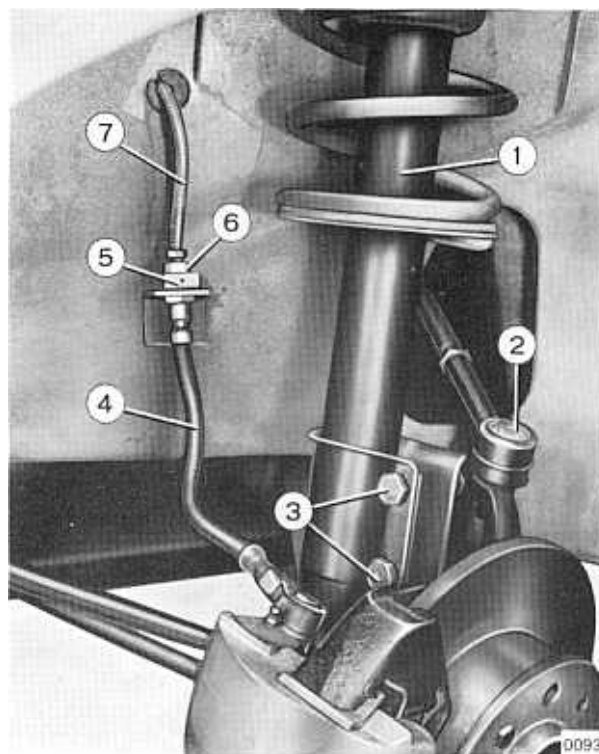

Fig. 07 2/3 - Front suspension

Refitting

- Reassemble in the reverse order and tighten the bolts holding the suspension to the body and swivel to the correct torque loadings.

§ 07 2 0700

REMOVAL AND REFITTING OF THE ARMS

Stand the vehicle over the pit and *proceed as follows*:

Removal

- Loosen the front wheel stud bolts. Lift the vehicle from inside the pit with a pillar lift. Take off the wheels.

- Unscrew the nuts and remove bolts (1) and (2). Unscrew nuts (3) and collect their lock washers. Use tool 88062036 to extract the pins, unscrew parts (4) and remove the arms from the body mounting.

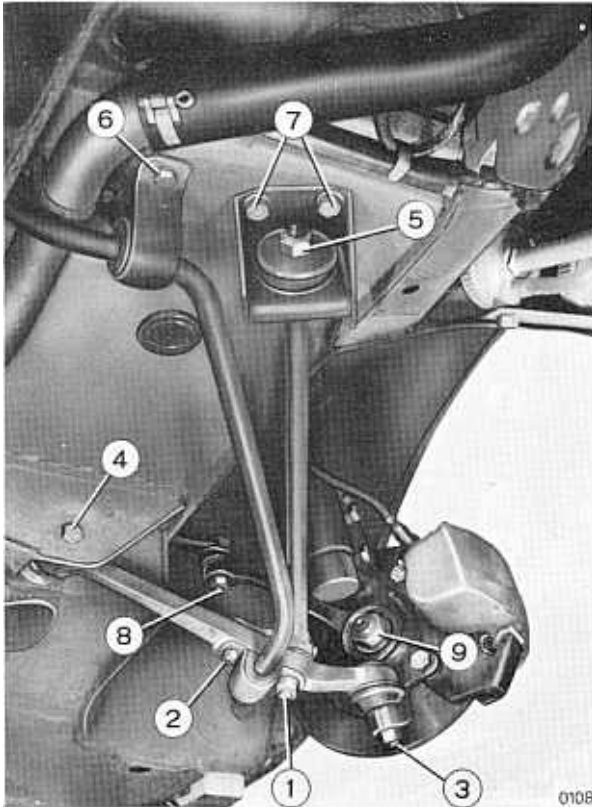

Fig. 07 2/4 - Front suspension arm

Refitting

- Clean all parts and the spaces in the chassis where the arms are housed. Reassemble in the reverse order.
- With the vehicle at its standing load, tighten parts (1, 2, 3 and 4) to the torque loadings shown.

TOOLS REQUIRED

- 88062036 - Extractor

§ 07 2 1000

REMOVAL AND REFITTING OF ARM ANCHORAGE ROD

Stand the vehicle over the pit and *proceed as follows*:

Removal

See fig. 07 2/4.

- From the pit, unscrew nut (5) and parts (1) & (2). Remove the anchorage rod, complete with silent blocks and spacers.

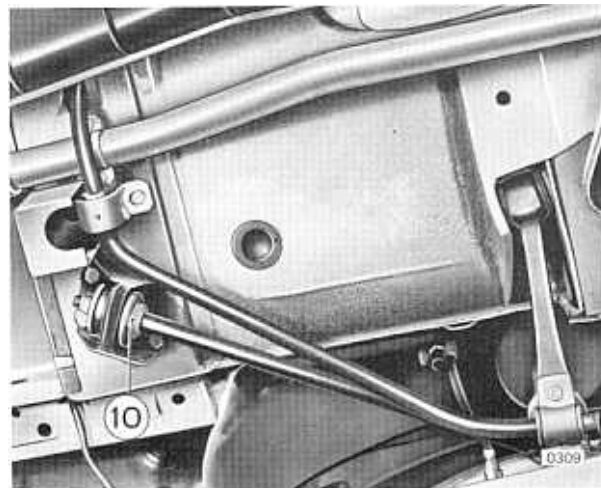

Fig. 07 2/5 - Rear view of arm anchorage rod

Refitting

- Reassemble in the reverse order. Make sure that the same number of spaces part. (10) are refitted to ensure that the caster angle of the wheel is not altered. Tighten parts (1, 2, 5) to the torque loadings shown (1).

(1) Checking and adjustment of the wheel caster angle are dealt with at para. 12 2 0010.

§ 07 2 1100

REMOVAL AND REFITTING OF FRONT
STABILISER BAR

Stand the vehicle over the pit and *proceed as follows*:

Removal

See fig. 07 2/6.

- From the pit, remove the cooling air duct, the brackets (2) and the clamps (4), and take off the stabiliser bar (1).

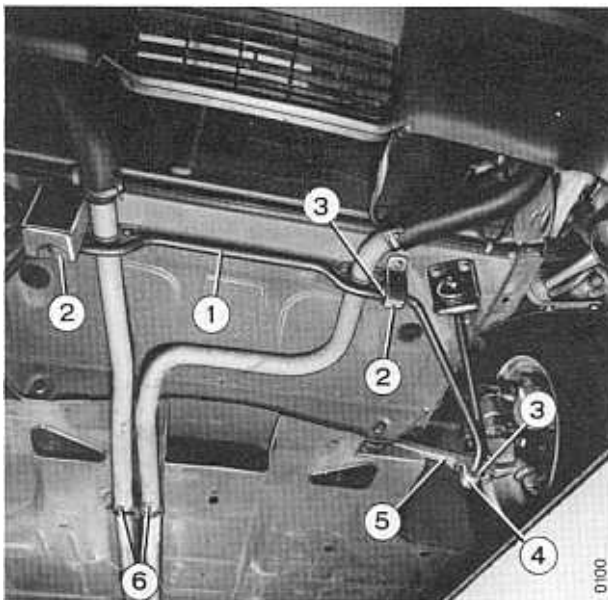

Fig. 07 2/6 - Front suspension, with stabiliser bar

Refitting

- Reassemble in the reverse order. The nuts for parts (2) and (4) must be tightened to the torque loadings shown with the vehicle at its standing load.

§ 07 2 1300

REPLACEMENT OF BUFFERS AT END OF
STABILISER BAR

Stand the vehicle over the pit and *proceed as follows*:

- From the pit, remove the clamps concerned (6) and slide off the buffers (5).

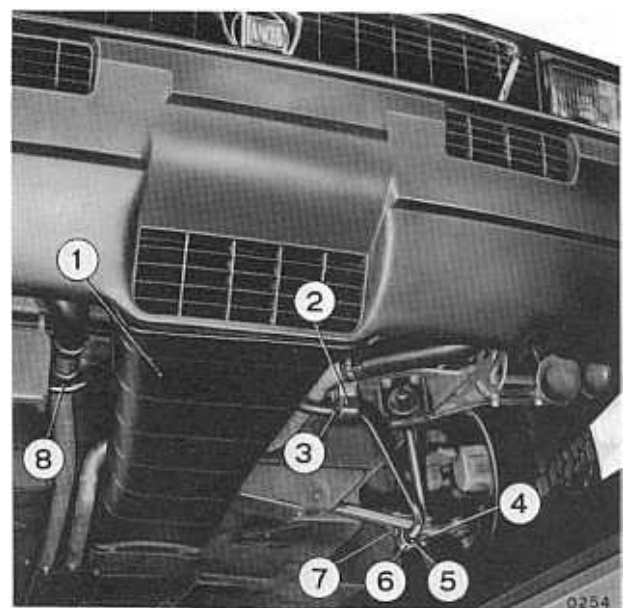

Fig. 07 2/7 - Front stabiliser bar

Refitting

- Slip the new buffers (5) on the bar (8) and reassemble the clamps (6). Nuts (4) and (7) must be tightened together.

Note: Soapy water will make it easier to insert the buffers. On no account use either oil or grease.

REAR SUSPENSION

§ 07 2 2200

RENEWAL OF STABILISER BAR BUFFERS

Stand the vehicle over the pit and *proceed as follows*:

Removal

- Slacken the rear wheel stud bolts. Lift the vehicle from the pit. Unscrew the parts (5) holding the support to the arm and slide off the buffer (6) from the stabiliser bar (7).

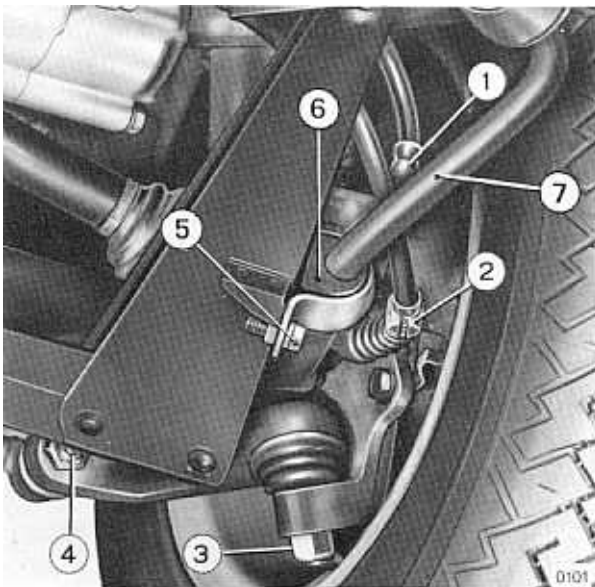

Fig. 07 2/8 - Rear stabiliser bar

Refitting

Mount new buffers (6) by sliding them onto the bar (7). Refit all parts in the reverse order. Tighten parts (5) to the correct torque loading with the vehicle at its standing load.

Note: Soap and water may be used to facilitate the mounting operation.

§ 07 2 2300

REMOVAL AND REFITTING OF REAR STABILISER BAR

Stand the vehicle over the pit and *proceed as*

follows:

Removal

- Loosen the nuts holding the rear wheels and lift the vehicle from inside the pit with a pillar lift. Remove the wheels.
- Unscrew parts (3 and 5) holding the stabiliser bar brackets (4) to the arms and parts (1 and 2). Remove the bar.

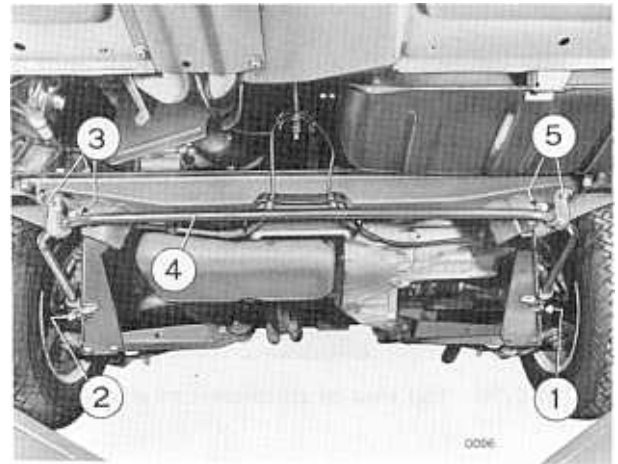

Fig. 07 2/9 - Rear stabiliser bar

Refitting

- Reassemble in the reverse order. With the vehicle at its standing load, tighten parts (1, 2, 3 and 5) to the torque loadings shown.

§ 07 2 2400

REMOVAL AND REFITTING OF THE REAR SUSPENSION

Stand the vehicle over the pit and *proceed as follows*:

Removal

- Loosen the stud bolts of the wheels concerned. Lift the vehicle from inside the pit with a pillar lift and rest it on trestles.
- Take off the wheels and the three nuts (1)

that attach the strut to the body.



Fig. 07 2/10 - Top view of attachment of strut to body

and the bolts shown as (2) in fig. 07 2/12.

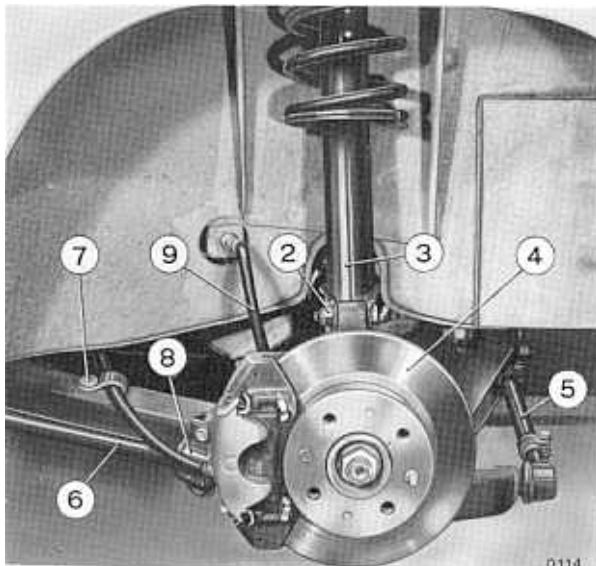

Fig. 07 2/11 - Rear suspension

Take off the rear suspension (3) and anchor the hub and brake calipers to the body to relieve the strain on the brake fluid hose (9).

Refitting

- Reassemble in the reverse order and tighten the nuts (1) attaching the strut to the body

and the bolts (2) to the torque loadings shown.

§ 07 2 2600

REMOVAL AND REFITTING OF ROD FOR REPLACEMENT OF ROD END, SLEEVE AND BALL JOINT

(excluding check and adjustment of toe-in) (*)

Stand the vehicle over the pit and *proceed as follows*:

Removal

- Unscrew the nuts (1) holding the clamps, withdraw the split pin, unscrew nut (3) and use extractor 88062036 (see fig. 07 2/13) to detach the ball joints (4) from the swivel (5).

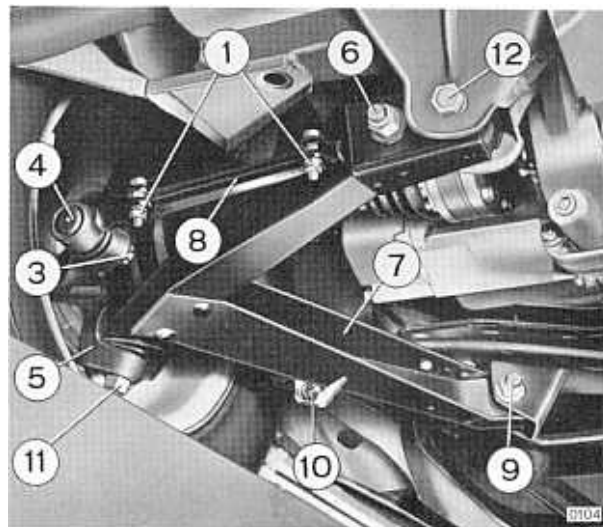

Fig. 07 2/12 - Arm and rear transverse rod

- Unscrew bolt (6) from the arm 7 and slide off the rod 8; disassemble the ball joint (4) from the sleeve and the end, complete with the silent block (1).

Refitting

- Reassemble in the reverse order. Make sure that the threaded parts of the ball joint and end are equally distributed over the sleeve.

(*) Checking and adjustment of the toe-in are dealt with at para. 08 2 0600.

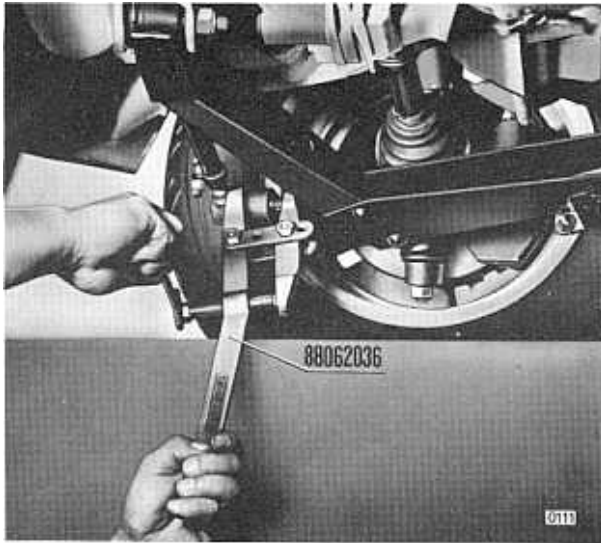

Fig. 07 2/13 - Tool for extracting the ball joints.

Tighten parts (3) and (6) to the torque loadings shown with the vehicle at its standing load.

TOOLS REQUIRED

- 88062035 - Extractor

(1) Replace both ends, complete with their silent blocks, to ensure that both suspensions operate on the same plane.

§ 07 2 3000

REMOVAL AND REFITTING OF THE ARMS

Stand the vehicle over the pit and *proceed as follows*:

Removal

- Unscrew the six bolts that attach the half-shaft concerned on the differential side. Slacken the stud bolts holding the wheel. From the pit, lift the vehicle and rest it on trestles. With ref. to fig. 07 2/14.
- Take off the stabiliser bar from the centre (2) and side (1) clamps, and the rubber band (4) that holds the hand-brake cable.
- Take off the wheel. Uncrimp the wheel bearing mounting nut. Mount tool 88053151.

as shown in fig. 07 2/15 und unscrew this nut. Remove the transmission, complete with shaft with flange for wheel side coupling.

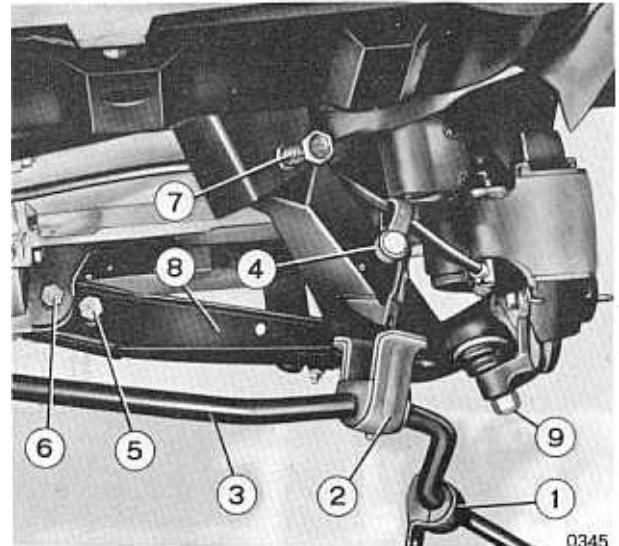

Fig. 07 2/14 - Mounting of tool for holding wheel hubs

- Unscrew nut (9) and use extractor 88062036 to take the ball joints off the swivel. Unscrew the pin nuts (6) and (7) holding the arms to the body bracket. Remove the pin (5) holding the rod to the arm and then slide off the arm from its attachment to the body and the swivel. (In this operation, the rod remains clamped to the swivel).

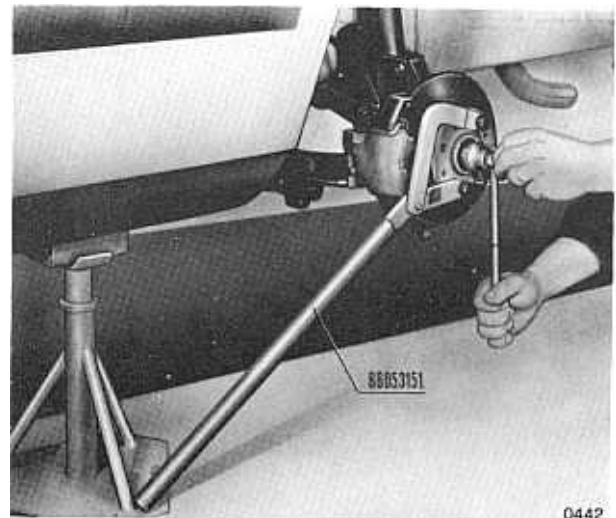

Fig. 07 2/15 - Removal of ball joint from swivel

Refitting

- Reassemble in the reverse order. Tighten the transmission mounting bolts, the nut holding

the wheel bearing, and parts (1, 2, 5, 6, 7 and 9) to the correct torque loadings, with the vehicle at its standing load.

TOOLS REQUIRED

- 88053151 - Lever for holding wheel hubs
- 88062036 - Ball joint extractor

§ 07 2 3100

REPLACEMENT OF REAR ARM SILENT BLOCKS

Stand the vehicle over the pit and *proceed as follows*:

- Lift the vehicle and rest it on trestles. Remove the centre (1) and side (2) clamps holding the stabiliser bar (3). Remove the rubber band (4). Unscrew the nuts from pins (6) & (7) and remove them. Slide off the arm, complete with the silent blocks, from its fittings.

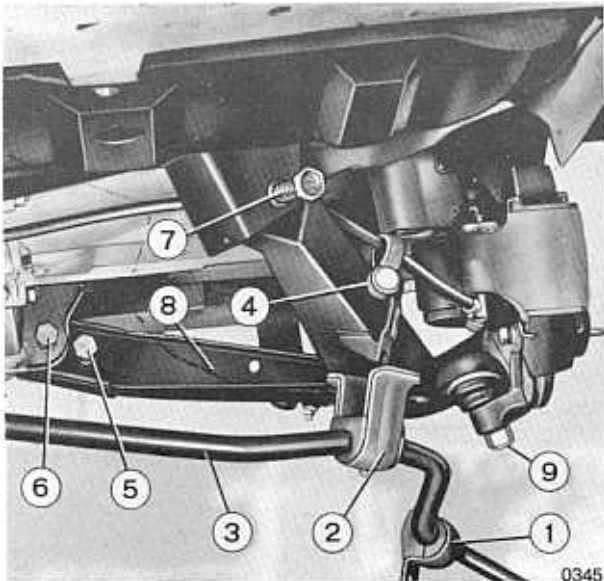

Fig. 07 2/16 - Rear arm

- Fit extractor 88042121,5 in the blocks, as shown in the figure, and remove them.

Note: the blocks must be replaced on both arms.

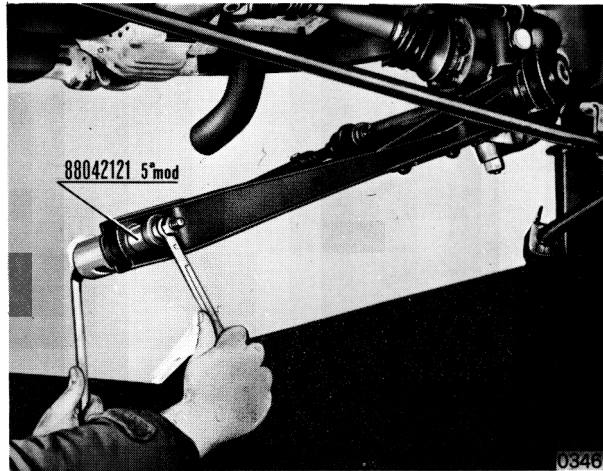

Fig. 07 2/17 - Removal of the silent blocks

Assembly

- Clean the seatings of the blocks in the arm. Insert the new blocks with the aid of extractor 88032121 - 5a, with its parts assembled as shown in the figure. The correct axial position of the block will be obtained by screwing the tool fully down.

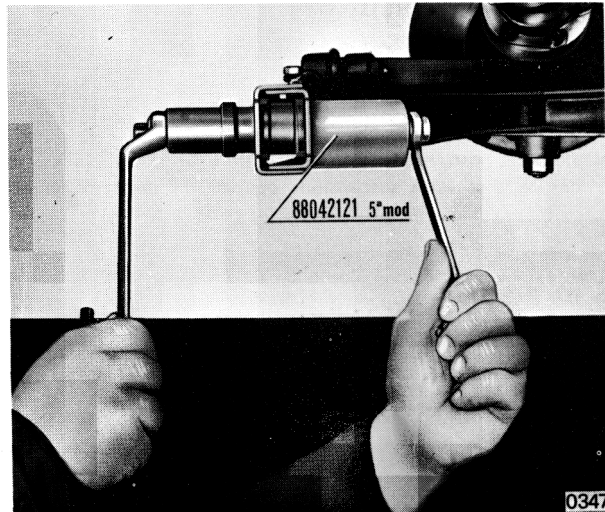

Fig. 07 2/18 - Insertion of silent blocks into the arm.

- With the vehicle at its standing load tighten the bolts holding the stabiliser bar side clamp and parts (6 & 7) holding the arm on the correct torque loadings.
- Repeat these operations to replace the blocks on the other arm.

TOOLS REQUIRED

- 88042121 - 5a Silent block extractor and inserter

CHAPTER 4

SUSPENSION

§ 07 4 0200

REPLACEMENT OF SWINGING ARM SILENT BLOCKS FRONT SUSPENSION

Disassembly

- Remove the spacer from the silent block by means of a press and punch;

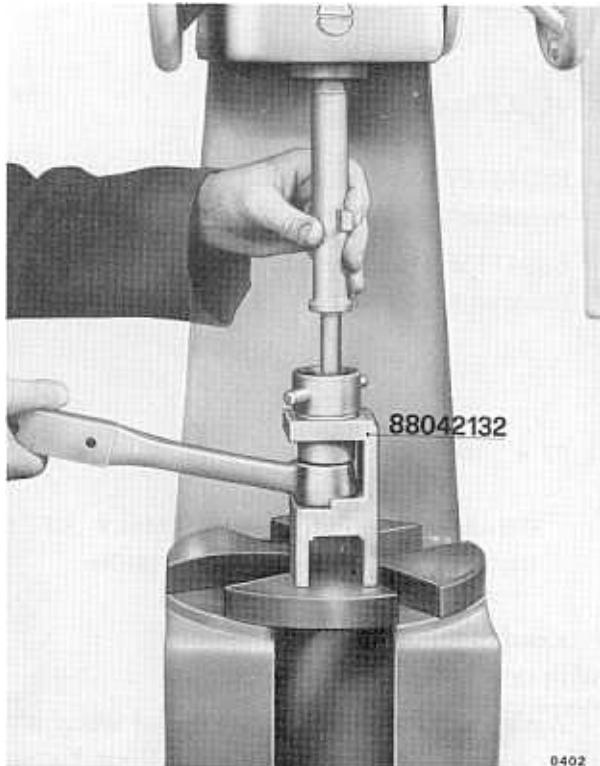

Fig. 07 4/1 - Extractor for forcing out silent block pin.

- and using the press, remove the silent block from its seat.

Reassembly

- Lubricate the new blocks and spacers with soap and water; fit the blocks to the punch of tool 88042132, set the tool and arm below the press and drive in the blocks (1).

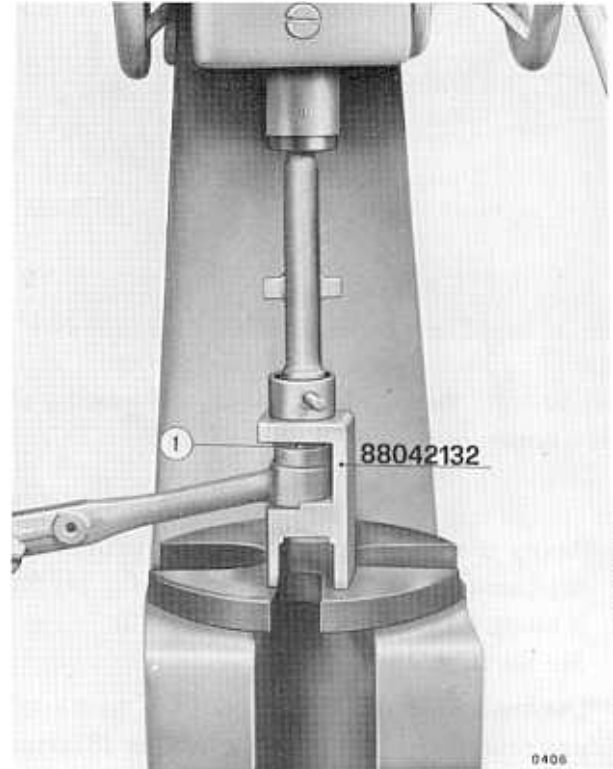

Fig. 07 4/2 - Silent block inserter.

- Unscrew the guide cone from the pin, insert the spacers in the pin and, using press and inserter 88042132, fit the spacers in the swinging arm blocks; then extract the punch and the arm of tool 88042132.

TOOLS REQUIRED

- 88042132 - Front arm silent block extractor-inserter.

§ 07 4 1000

DISASSEMBLY AND REASSEMBLY OF A (RIGHT OR LEFT) FRONT SUSPENSION

Proceed as follows:

- Wash the suspension with a jet of water and blow dry with compressed air; lock fixture 88043127 in a vice and unscrew the support screws (2). Insert the suspension in the fixture as shown.

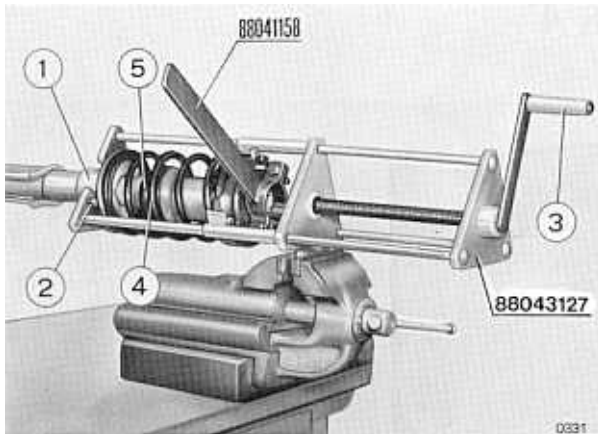

Fig. 07 4/3 - Fixture for disassembly and assembly of front suspension

- Apply the sliding ring (1) to the strut, turn the crank (3) and compress the spring (4) till it no longer presses on the bumper (5). See fig. 07 4/4.
- Use spanner 88041158 to hold the stem cup, unscrew nut (6), remove the washer (8), cup (7) and pad (8) from the stem, together with the spacer, shoulder washer, bush, bearing (10), thrust plate (11) and bumper (13).

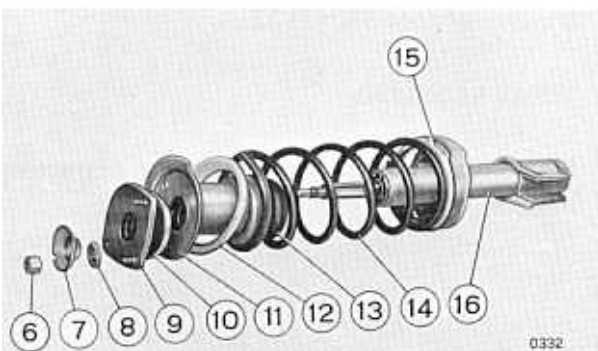

Fig. 07 4/4 Components of the complete front suspension

- Turn the crank to unload the spring (14), turn the ring (1) and free the strut (16), and extract the suspension. Free the fixture from the vice.
- Remove the pad (12), spring (14) and second pad (15).

- Check all disassembled components and replace for wear or damage as necessary. Check the coil spring and replace if necessary (as described in sheets).

Reassembly

- Grease bearing (10) and replace the suspension inside the fixture. Make sure the shape of the spring and its cups mates with the thrust plates. Remount all parts in the same order as for disassembly.
- Tighten to the correct torque loadings. Slacken the fixture and slide out the suspension.

TOOLS REQUIRED

- 88043127 - Suspension disassembly and reassembly fixture
- 88041158 - Spanner to hold the cup during unlocking and locking of telescopic strut nut

§ 07 4 1100

DISASSEMBLY AND REASSEMBLY OF A (RIGHT OR LEFT) REAR SUSPENSION

Proceed as follows:

With reference to fig. 07 4/3

- Wash the suspension with a jet of water and blow dry with compressed air; lock fixture
- 88043127 in a vice, insert the suspension, lock the strut by turning the ring (1), unscrew the support screws (2), and turn the crank (3) to compress the spring. Apply spanner 88041158 to hold the stem cup.

With reference to fig. 07 4/5

- Unscrew the stem lock nut, and remove the washer, cup pad (2), top thrust plate (3) and the second pad (5).
- Use the crank to fully release the pressure exerted by the spring. Slide the telescopic strut (7), top pad (6), spring (4) and bottom pad (6) out of the fixture.

Check all disassembled components and replace for wear or damage as necessary. Check the coil spring and replace if necessary (as described in the sheets).

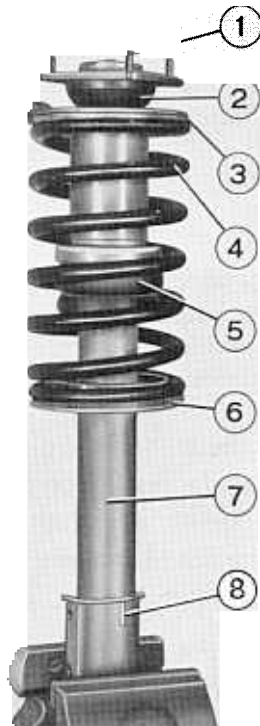

0334

Fig. 07 4/5 - Rear suspension components

Reassemble in the reverse order. Screw up the lock nut. Unscrew the guide pin from the stem. Tighten the shock-absorber lock nut to the correct torque loading.

TOOLS REQUIRED

- 88043127 - Fixture for disassembly and reassembly of rear suspension
- 88041158 - Ring nut lock spanner
- 88033425 - Guide pin for reassembly of suspension

§ 07 4 1200

**DISASSEMBLY AND REASSEMBLY OF A
(FRONT OR REAR) TELESCOPIC STRUT**

Proceed as follows.

Disassembly

- Clean the strut with water and a brush. Lock the foot of the strut in an aluminium-jawed vice. Use spanner 88031010 to dismount the lock nut as shown in fig. 07 4/6.

Reassembly

- When reassembling line the pin (1) up with reference (8).
- Screw the guide pin 88033425 on the stem of the telescopic strut to enable it to be inserted into the top thrust plate.

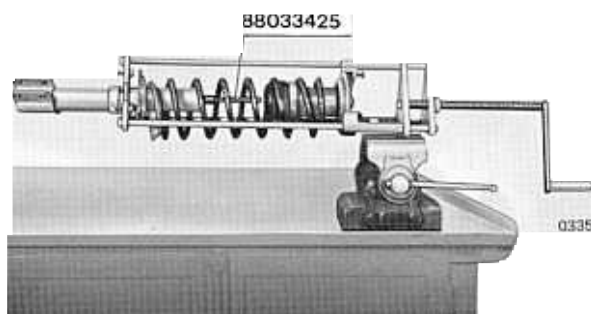

0335

Fig. 07 4/6 - Fixture 88043127 and guide pin 88033425 for reassembly of rear suspension

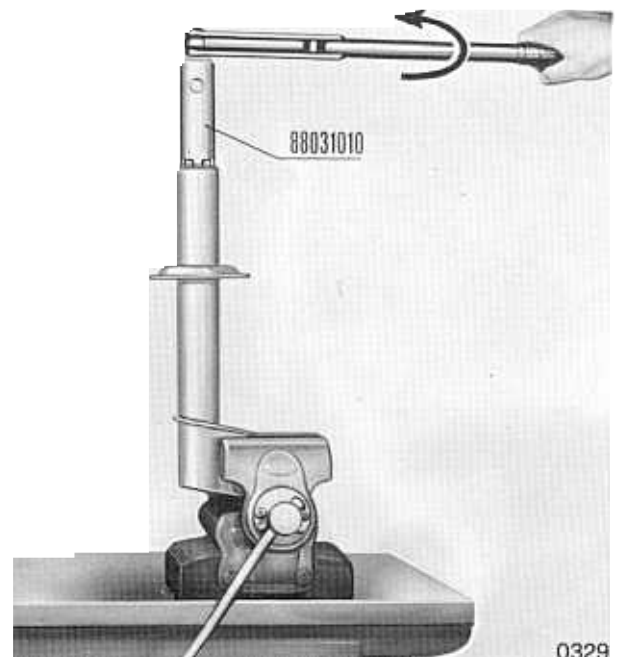

0329

Fig. 07 4/7 - Front telescopic strut

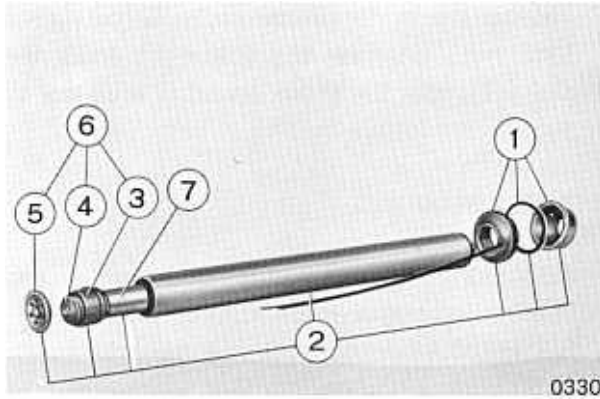

Fig. 07 4/8 - Front strut (disassembled)

- Remove the strut from the vice, turn it over and collect the oil it contains, then slide the complete stem out from the strut.
- Check the disassembled parts and replace for wear or damage in sets, as follows: (1) group of washers with ring nut and tube; (2) inner strut assembly (6) damper valve and compression valve assembly.

Reassembly

- Place oil of the right type and quantity (as shown in the data sheets) in the strut. Insert the inner strut assembly very slowly to give the air bubbles the chance to escape.

- Slip set (1) into the stem and strut. Make sure that the washers, ring nut and tube are correctly inserted. Tighten the ring nut to the correct torque loading (*).

(*) Bench testing of the telescopic strut is described in para. 16 4 5100.

§ 07 4 1210

REPLACEMENT OF TELESCOPIC STRUT DAMPER VALVE (not including removal and refitting of strut)

With reference to fig. 07 4/8:

- Slide out the stem (7) from the cylinder (2) and remove the seal (5) on the cylinder. Lock the stem in an aluminium-jawed vice and unscrew the nut (4) holding the damper valve. Remove the valve.
- Reassemble the damper valve parts in the same order in which they were disassembled. Fit nut (4) that holds the damper valve with a lock tab and assemble the remaining parts in the reverse order.

N.B.: The compression valve (5) forming part of assembly (6) must also be replaced during this operation.

BASIC MODEL

The directions and operations refer to the hubs, wheels and tyres fitted to all car models.

HUBS, WHEELS AND TYRES GROUP CONTENTS

CHAPTER 1

Troubles, probable causes, checkings and operations to be carried out

from page 08 1/1

to page 08 1/2

CHAPTER 2

- § 08 2 0100 Removing and refitting of swivel complete with flange and front wheel hub bearing page 08 2/1
§ 08 2 0400 Removing and refitting the rear carrier complete with hub wheel and bearing " 08 2/1

CHAPTER 4

- § 08 4 0300 Renewing of front wheel hub, or the bearing " 08 4/1
§ 08 4 0700 Renewing of rear hub bearing and carrier 08 4/2
§ 08 4 0900 Balancing the loose wheels by means of CEMB L1/L, or L1E/L type balancing machine 08 4/4

FAULT	PROBABLE CAUSES	CHECKS ADVISABLE BEFORE REPAIRING	ACTION NECESSARY	PARA
Uneven front tyre wear	Incorrect toe-in	—	Checking of wheel geometry with optical equipment and adjustment of toe-in if necessary	
	Incorrect front wheel geometry	—	Removal and refitting of suspension arms Removal and refitting of swivel	07 2 0700 12 2 4000
	Wheels not balanced	Check for vibration in the steering wheel when driving	Balancing the wheels	08 4 0900
	Incorrect tyre pressure	—	Correct tyre pressure	
Noisy wheel hubs	Worn front hub bearings	—	Removal and refitting of swivel Renewal of front hub bearing	12 2 4000 08 4 0300
	Worn rear hub bearings	—	Removal and refitting of rear hub Renewal of rear hub bearing	08 2 0400 08 4 0700

FAULT	PROBABLE CAUSES	CHECKS ADVISABLE BEFORE REPAIRING	ACTION NECESSARY	PARA
Uneven rear tyre wear	Incorrect rear wheel geometry	—	Checking of wheel geometry with optical equipment Removal and refitting of right or left transverse link	— 07 2 2600
	Rear suspension transverse links out of adjustment or distorted	—	Checking of wheel geometry with optical equipment Removal and refitting of right or left transverse link	— 07 2 2600
	Incorrect tyre pressure	—	Correct tyre pressure	
	Wheels not balanced	—	Balancing the wheels	08 4 0900

)

CHAPTER 2

§ 08 2 0100

REMOVAL AND REFITTING OF SWIVEL COMPLETE WITH FLANGE AND FRONT WHEEL HUB BEARING

Removal

- Stand the vehicle over the pit, slacken the stud bolts of the wheel concerned, lift the vehicle and rest it on trestles, and take off the wheel.
- Unscrew the two bolts holding the brake caliper. Remove caliper complete with carrier and place it to one side. Unscrew the two bolts holding the brake disc and remove same.
- Unscrew the nut holding the pin joining the arm to the swivel and the nut (1) holding the steering rod to the swivel.
- Fit removing tool 88062026 as shown in the figure and use it to drive off the two ball joints. Unscrew the bolts holding the swivel to the strut and take off the swivel.

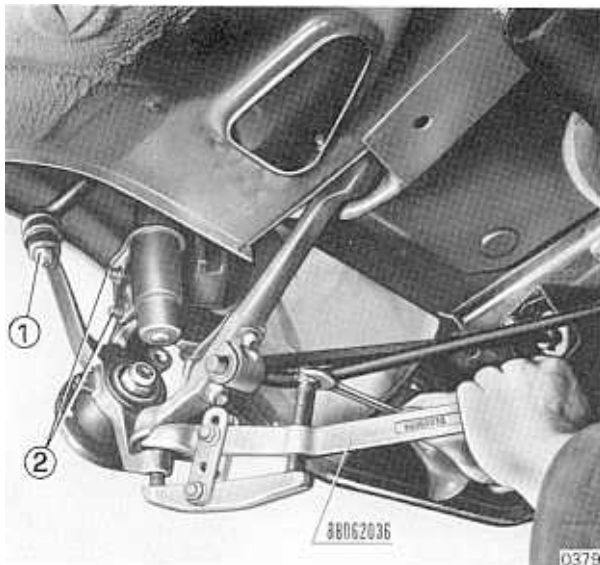

Fig. 08 2/1 - Removing tool for swivels

Refitting

- Refit in the reverse order and tighten parts (1) and (2) of the swivel and the bolts holding the disc and caliper to the correct torque

loadings.

TOOL REQUIRED

- 88062036 Removing tool for swivels

§ 08 2 0400

REMOVAL AND REFITTING OF REAR CARRIER COMPLETE WITH HUB, WHEEL AND BEARING

Stand the vehicle over the pit and *proceed as follows*:

Removal

- Slacken the stud bolts of the wheel concerned, lift the vehicle and rest it on trestles, and take off the wheel.
- Uncrimp the nut holding the wheel bearing. Fit tool 88083151 as shown in the photo and unscrew the nut.

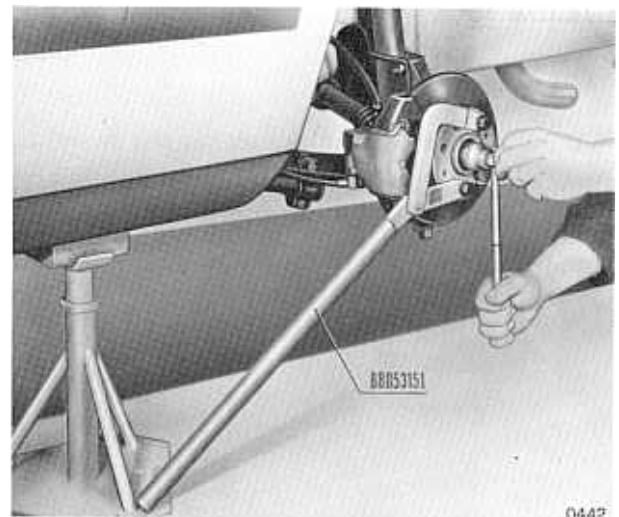

Fig. 08 2/2 - Removal of bearing attachment nut

- Unscrew the two bolts holding the caliper to the swivel nut move the caliper to one side. Unscrew the two bolts holding the brake disc plate and the disc and take off these two parts.

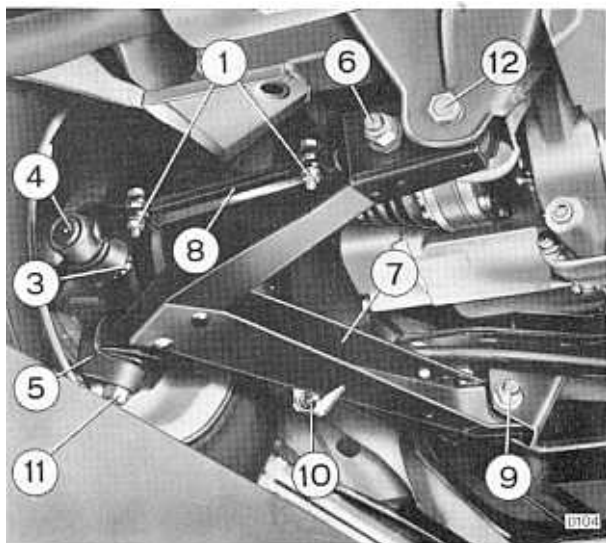

Fig. 08 2/3 - Detail of rear suspension

- Unscrew nut (11). Take out split pin and unscrew nut (3).
- Use removing tool 88062036 to drive off the pin (4) and the pin holding the arm (7) to the carrier (5).
- Unscrew the two bolts holding the swivel to the strut, block the half-shaft (if necessary, drive off with tool 88052009) and take off the carrier.

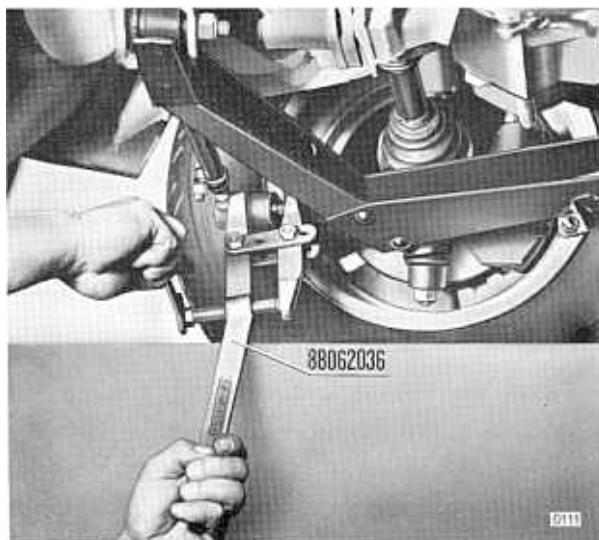

Fig. 08 2/4 - Driving off the pin

Refitting

- Refit in the reverse order and tighten the following parts to their correct torque loadings: bolts holding strut to carrier; nut (11); nut (3); bolts holding brake disc; bolts holding brake caliper carrier; nut holding wheel bearing.

TOOLS REQUIRED

- 88052009 - Wheel hub remover
- 88053151 - Lever arm for holding wheel hubs
- 88062036 - Removing tool for swivels

CHAPTER 4

§ 08 4 0300

RENEWAL OF FRONT WHEEL HUB OR BEARING

Disassembly

- Lock the swivel in a vice and unscrew the nut holding the bearing, the washer, the guard and the cup sealing the guard; use a press to drive off the hub from the swivel.

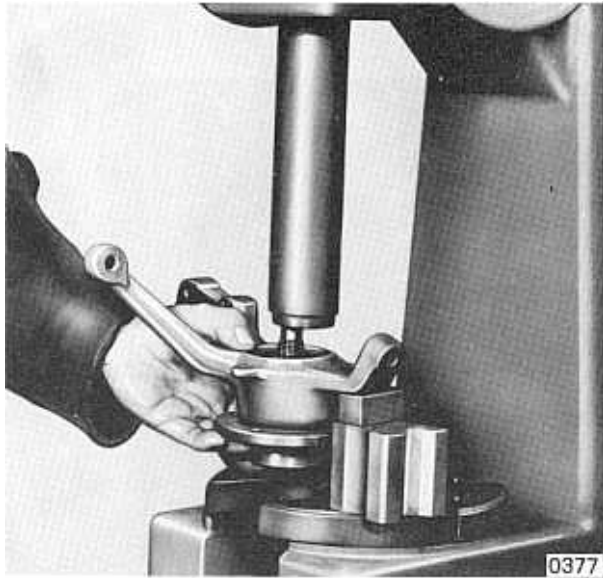

Fig. 08 4/1 - Detachment of hub from swivel



Fig. 08 4/2 - Detachment of bearing from swivel

- If the inside inner race half-ring is left on the hub during this operation, it can be removed by making two grooves at 180° from each other and no more than 2 mm deep must be made with portable grinder 88096779 and grinding wheel 88503528. Drive the half-ring from the swivel with the aid of puller 88092031.

Note: the bearing and ring nut must always be renewed, since they cannot be re-used.

Reassembly

- Wash all parts, especially the bearing housing in the swivel, with paraffin. Examine the hub for wear and renew if necessary.

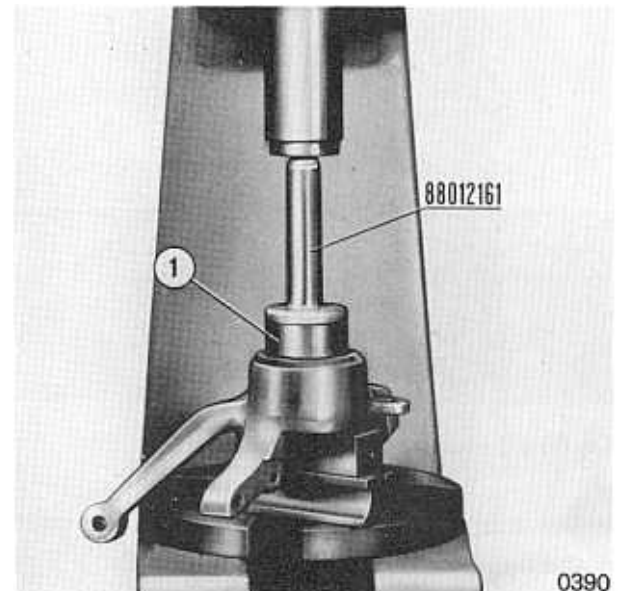

Fig. 08 4/3 - Insertion of bearing into swivel.

- Use a press and installer 88012161 to mount the new bearing on the swivel.

- Lock the swivel in a vice. Tighten the ring nut with spanner 88051174 and crimp it.

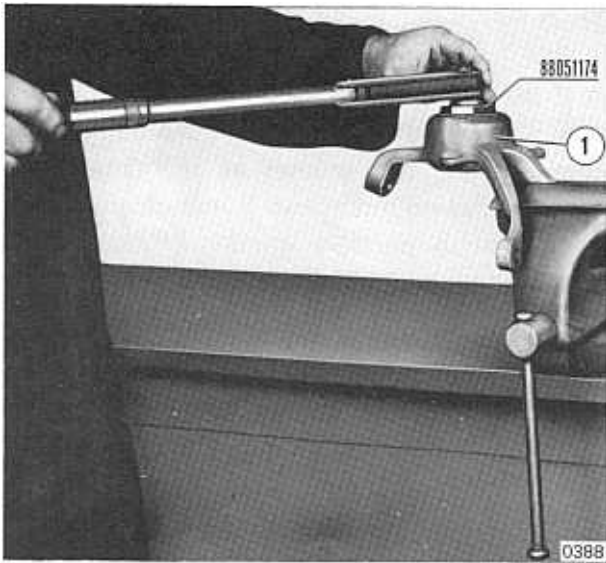

Fig. 08 4/4 - Reassembly of bearing ring nut

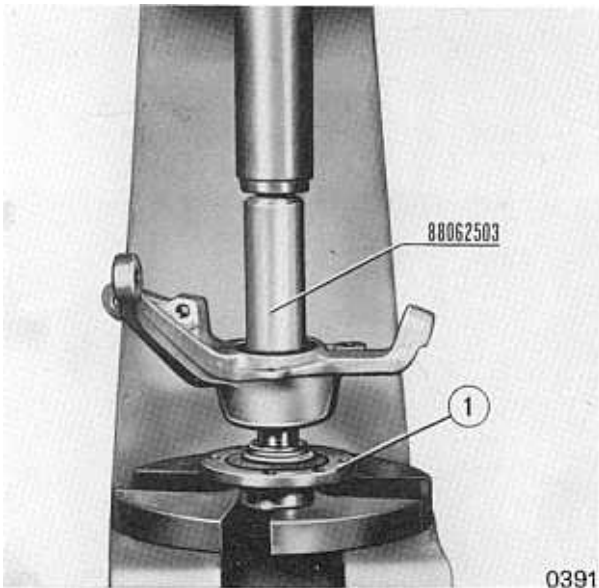

Fig. 08 4/5 - Insertion of hub in the swivel

- Use a press and installer 88062503 to insert the hub on the swivel.

TOOLS REQUIRED

- 88051174 - Spanner for front wheel hub bearing ring nut
- 88012161 - Installer for front wheel swivel bearings
- 88062503 - Front swivel bearing remover and front wheel hub bearing installer
- 88096779 - Portable grinder
- 88593528 - Grinding wheel

§ 08 4 0700

RENEWAL OF REAR HUB BEARING AND CARRIER

Remove the carrier as described at para. 08 2 0400 and *proceed as follows*:

Disassembly

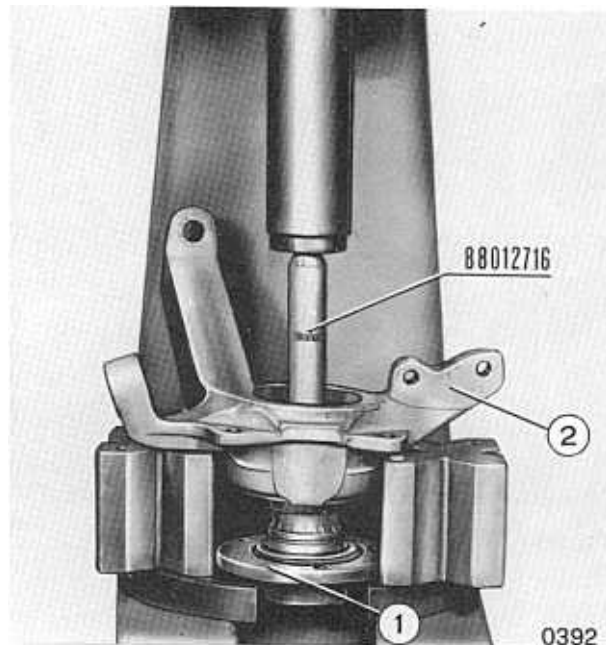

Fig. 08 4/6 - Detachment of hub from carrier

- Rest the carrier on two parallel blocks and use a press and removing tool 88012716 to drive off the hub (1).

- If the inner race is left on the hub during this operation, two grooves at 180° from each other and no more than 2 mm deep must be made with portable grinder 88096779 and grinding wheel 88503528. Puller 88092031 can then be used to remove the race.

- Uncrimp the ring nut and unscrew it with spanner 88051173.

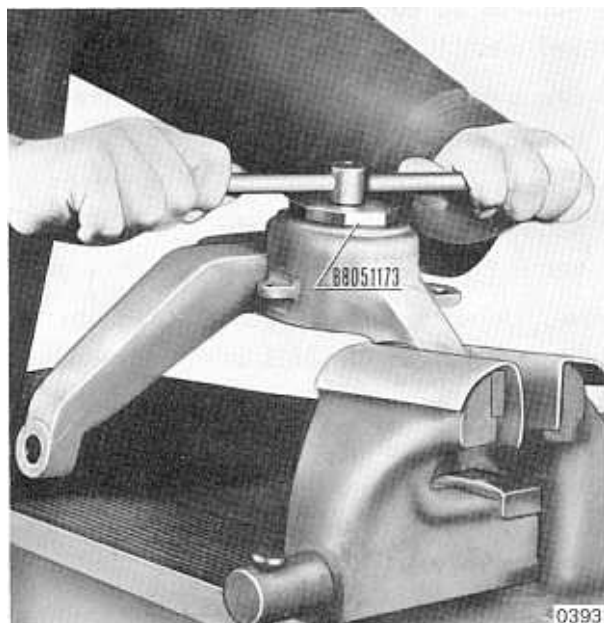

Fig. 08 4/7 - Detachment of ring nut from carrier.

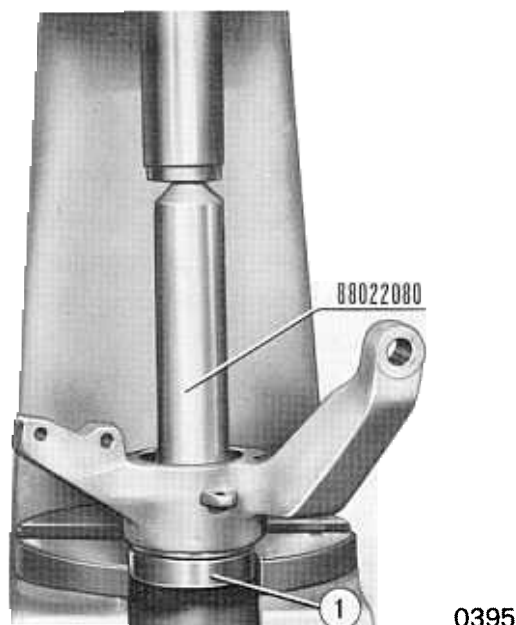

Fig. 08 4/8 - Detachment of bearing from carrier

- Use a press and removing tool 88022080 to drive bearing (1) from the carrier (2).

Note: the bearings and their ring nuts must always be renewed, since they cannot be re-used.

Reassembly

- Wash all parts, especially the bearing housing in the carrier, with paraffin. Examine the hub for wear and renew if necessary.
- Use a press and installer 88052018 to mount the new bearing in the carrier.

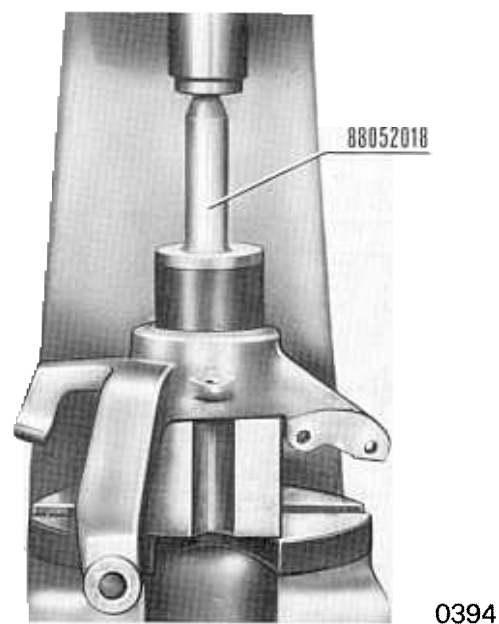

Fig. 08 4/9 - Insertion of bearing in the carrier

- Lock the carrier in a vice. Tighten the ring nut with spanner 88051173 and crimp it.
- Use a press and installer 88022080 to insert the hub in the carrier.

TOOLS REQUIRED

- 88096779 - Portable grinder
- 88503528 - Grinding wheel
- 88051173 - Spanner for rear wheel hub bearing ring nut
- 88012716 - Removing tool to take rear wheel hubs from carriers
- 88052818 - Installer to insert bearings in rear wheel carriers
- 88022080 - Installer for insertion of hub in carrier

§ 08 4 0900

BALANCING THE LOOSE WHEELS BY MEANS OF CEMB L1/L OR L1E/L BALANCING MACHINE

Warning: The balancing machine CEMB L1/L 88056005 or L1E/L 88055010 can only be used to balance wheels lighter than 30 kg.

Proceed as follows.

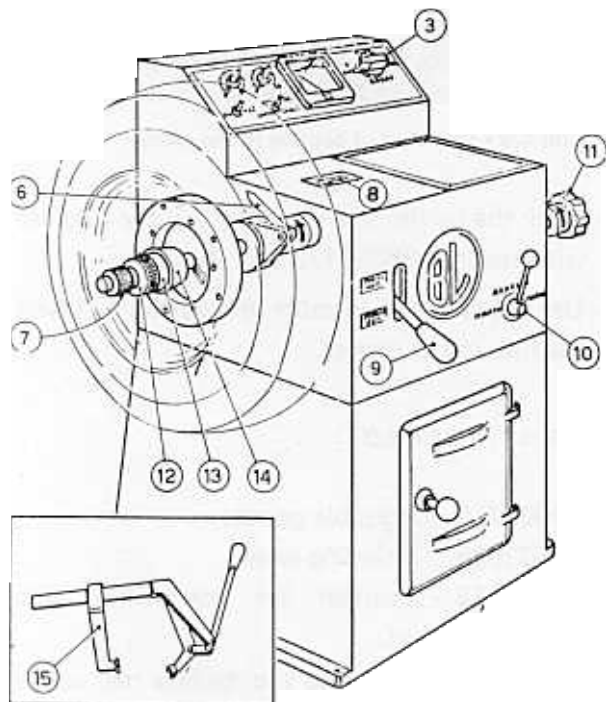
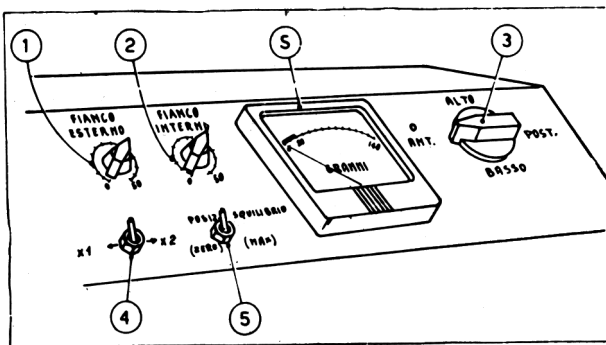

Fig. 08.4/10 - Balancing machine for loose wheels.

1. Knob for setting outer side of wheel. - 2. Knob for setting inner side of wheel. - 3. Knob for balancing wheels with bolts. - 4. Switch for reading imbalance value at end of scale. - 5. Switch for reading imbalance. - 6. Joint rod for correct wheel positioning. - 7. Universal flange locking nut. - 8. Lever for locating position of counterweight on rim. - 9. Lever for balancing inner and outer sides of wheel. 10. Lever for starting and stopping machine. - 11. Instrument zero setting knob. 12. Wheel mounting nut. - 13. Spacer. - 14. Wheel mounting cone. - 15. Clamp. S. Imbalance indicator instrument.

– Remove all counterweights from the wheel and wash it.

– Check the condition of rim and tyre and inflate tyre to operating pressure.

– Fit the wheel to universal flange 88053162 or 88053164 and secure it with the cone (14), spacer (13) and ring nut (12).

Note: Universal flange 88053163 has to be used with the CEMB L1E/L balancing machine.

– Loosen the nut (7) and move the wheel axially until the inner edge of the rim (where the counterweights will be applied) comes into contact with the joint rod end (6); then tighten the nut (7).

– Move lever (9) to the "Outer side" position and turn knobs (1) and (2) to the setting values shown in the table.

– Set switch (5) at "zero" and start the balancing machine by means of lever (10) (make sure that the wheel turns in the direction of the arrow).

– Visually check radial and side wheel centering.

– If the wheel is out of true, see whether the rim is also; mark the position of the tyre with respect to the rim and remove the wheel from the balancing machine.

– Deflate the tyre and turn it 45° with respect to the rim.

– Inflate the tyre and fit the wheel on the balancing machine again. If the wheel is still out of true, keep turning the wheel in angles of 45° with respect to the rim.

If it proves absolutely impossible to correct the run out of the tyre, replace it. Out-of-true must also be replaced.

If the wheel is true, proceed as follows:

– Zero set the instrument "S" by turning the knob (11) in the direction of the arrow and set switch (5) in the position of "Max. imbalance".

– The reading on the "S" instrument is the weight in grammes to be fitted to the rim.

– Stop the machine by shifting the lever (8) to "Brake" position.

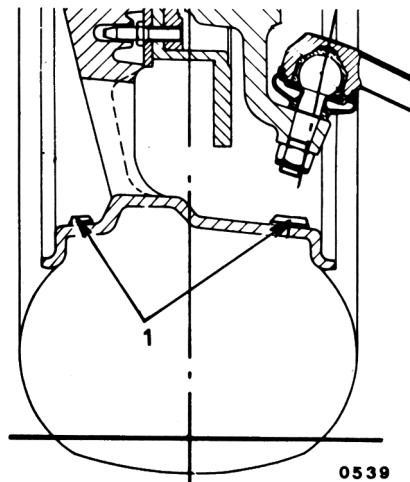

Fig. 08 4/11 - Points at which counterweights should be applied in the case of special light alloy wheels.

- Turn the wheel by hand until the red arrow (8) lights up, thus indicating the position where the counterweight is to be applied. The weight of this is shown on the instrument.
- Holding the wheel in this position (arrow lit up), apply the counterweight to the outside at the highest point of the rim.

Note: For balancing special light alloy rims, self-adhesive counterweights should be fitted to the points shown in fig. 08 4/8 following thorough cleaning of the rim.

- Shift lever (9) to "Inner side" position and set switch (5) at "zero"; restart the machine and zero set the instrument by means of the knob (11).
- Set the switch (5) to "Max. imbalance" and take the reading.
- Stop the balancing machine and proceed as before, applying a counterweight of the value indicated on the instrument at the highest point of the inside of the rim. as indicated by the luminous arrow (8).
- Again check the balance of the outside of the wheel and then remove the wheel from the balancing machine.

TOOLS REQUIRED

- 88053162/4 - Universal flange for CEMB L1/L.
- 88053163/9 - Universal flange for CEMB L1E/L.
- 88056005 - CEMB L1/L balancing machine.
- 88056010 - CEMB L1E/L balancing machine.

BASIC MODEL

The directions and operations refer to the brake system fitted to all car models.

BRAKES GROUP CONTENTS

CHAPTER 1

Troubles, probable causes, checkings and operations to be carried out

from page 09 1/1
to page 09 1/3

CHAPTER 2

§ 09 2 0100	Renewal of the hand brake cable	page 09 2/1
§ 09 2 0500	Removal and refitting the handbrake lever	" 09 2/1
§ 09 2 1300	Adjusting the handbrake	" 09 2/2
§ 09 2 1700	Removal and refitting of the brake pump	" 09 2/3
§ 09 2 1800	Removal and refitting the servo unit	" 09 2/3
§ 09 2 1840	Removal and refitting the brake fluid pressure drop indicator	" 09 2/4
§ 09 2 2200	Removal adjustment and refitting of the brake pedal	" 09 2/4
§ 09 2 3700	Removal and refitting of a front, or rear brake caliper	" 09 2/5
§ 09 2 4100	Removal and refitting of a brake caliper carrier	" 09 2/6
§ 09 2 4500	Removal and refitting of the brake discs	" 09 2/8
§ 09 2 4600	Checking the alignment of the front or rear brake discs	" 09 2/9
§ 09 2 4900	Renewal of brake friction pads	" 09 2/9
§ 09 2 5300	Bleeding the hydraulic brake circuits	" 09 2/10

CHAPTER 4

§ 09 2 0100	Overhaul the master cylinder	page 09 4/1
§ 09 4 0800	Overhaul of a front brake caliper carrier	" 09 4/2
§ 09 4 1000	Overhaul of a rear brake caliper carrier	" 09 4/2
§ 09 4 1600	Overhaul of the handbrake control	" 09 4/5

FAULT	PROBABLE CAUSES	CHECKS ADVISABLE BEFORE REPAIRING	ACTION NECESSARY	PARA
Excessive brake pedal travel	Excessive back stroke of one or more caliper pistons due to misalignment of the discs	Take off the wheel. Turn the disc by hand and check its alignment with a gauge	Checking the front or rear brake disc alignment Removal and refitting of front or rear brake discs	09 2 4600 09 2 4500
Poor braking and pedal travels almost all the way down	Faulty master cylinder section	—	Removal and refitting of servo unit and master cylinder Overhaul of master cylinder	09 2 1800 09 4 0100
	Loss of brake fluid from pipes or unions	Check for leaks by eye	Repair leaks and bleed hydraulic brake circuits	09 2 5300
	Loss of brake fluid from caliper cylinders	Check for leaks by eye	Removal and refitting of front or rear brake caliper Overhaul of front brake caliper cylinder Overhaul of rear brake caliper cylinder	09 2 3700 09 4 0800 09 4 1000
Spongy brake pedal	Air in the circuit	—	Bleed brake hydraulic circuits	09 2 5300

FAULT	PROBABLE CAUSES	CHECKS ADVISABLE BEFORE REPAIRING	ACTION NECESSARY	PARA
Stiff pedal action but poor braking effect	Defective operation of servo unit		Removal and refitting of servo unit and master cylinder	09 2 1800
	Leaks in servo unit vacuum line	Check line for leaks	Repair leaks	
	Friction pads hard or crystallised due to overheating	—	Renewal of front or rear friction pads	09 2 4900
	Crystallised brake disc surfaces	—	Removal and refitting of front or rear discs	09 2 4500
Pedal continues to go slowly down during braking	Inefficient master cylinder	Apply constant pressure on the pedal and see whether it tends to continue to move slowly down	Removal and refitting of servo unit and master cylinder Bench testing the master cylinder Overhaul of master cylinder	09 2 1800 16 4 5500 09 4 0100

FAULT	PROBABLE CAUSES	CHECKS ADVISABLE BEFORE REPAIRING	ACTION NECESSARY	PARA
Vehicle pulls to the left or right during braking	Oil or grease on one or more brake discs	—	Wash discs and friction pads with trichloroethylene	
	Defective operation of one or more calipers	—	Removal and refitting a front or rear caliper Overhaul of front caliper cylinder block Overhaul of rear caliper cylinder block	09 2 3700 09 4 0800 09 4 1000
Excessive hand brake lever travel and poor braking effect	Incorrect setting of hand brake lever	—	Adjustment of the hand brake	09 2 1300

CHAPTER 2

§ 09 2 0100

RENEWAL OF THE HAND-BRAKE CABLE

Stand the vehicle over the pit and *proceed as follows*:

Removal

- From below the vehicle, take off the lower engine guard, unscrew bolts (1) and (2), remove the anchor piece (4) from the

adjustment bolt (3) and the sheaths (5) from the bracket (6).

Compress the spring (7) and remove the ends of the cable from the brake calipers. Take off the rubber retainers (8) and remove the cable, complete with sheaths and return spring.

Reassembly

- Reassemble in the reverse order and adjust the brake as described at para 09 2 1300

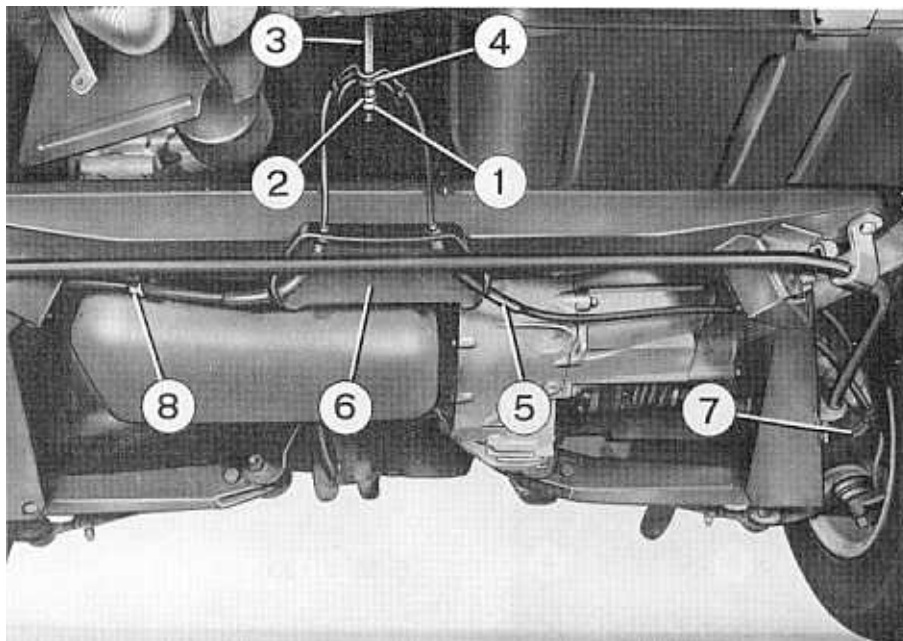

0103

Fig. 09 2/ Handbrake Control Linkage

§ 09 2 0500

REMOVAL AND REFITTING OF THE HAND-BRAKE LEVER

Stand the vehicle over the pit and *proceed as follows*:

Removal

- For refs. see fig. 09 2/1). From the pit, unscrew the bolts attaching the lower engine guard. Remove the guard, conternut (2) and nut (1), and slip off the stretcher (3) of the anchor piece (4).

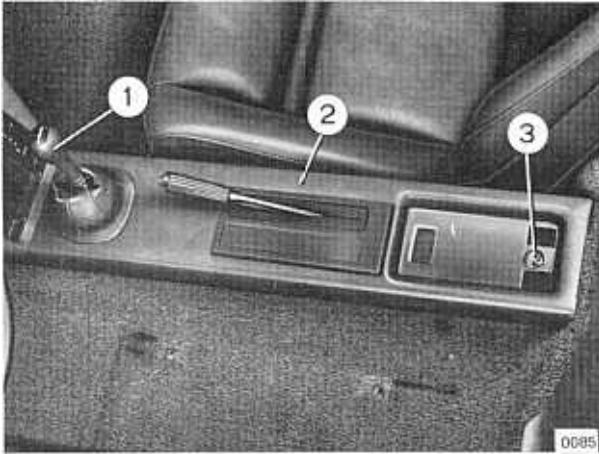

Fig. 09 2/2 - Removal of tunnel cover

- From inside the vehicle, unscrew the gear lever knob (1) and unscrew bolt (3) to take off the tunnel cover (2).

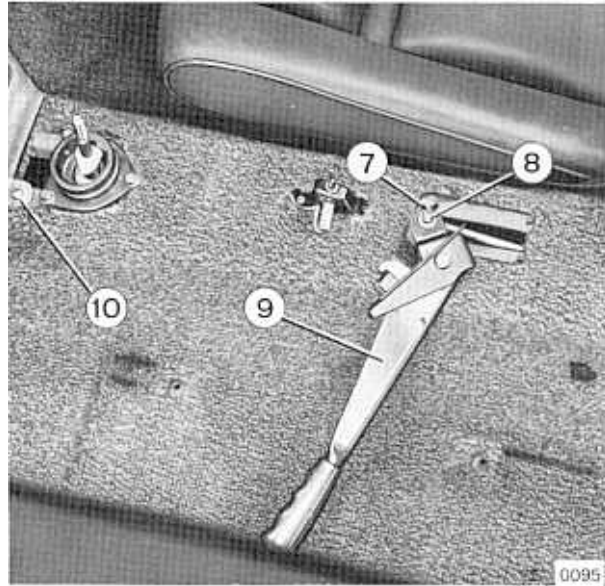

Fig. 09 2/4 - Removal of hand-brake lever

- Extract the cotter pin (7), slide out the pin (8) and remove the lever (9). (*)

Reassembly

- Reassemble in the reverse order. Check the effective operation of the brake on the rear wheels and adjust as described at para 09 2 1300. Check that the hand-brake telltale comes on after 2-3 clicks of lever travel and goes off when the lever is fully released.

(*) Overhaul of the hand-brake linkage is described at para 09 4 1600.

§ 09 2 1300

ADJUSTMENT OF THE HAND-BRAKE

Stand the vehicle over the pit, fit covers 88083056 and *proceed as follows*:

- Work the brake pedal up and down a few times hard to bring the pistons into the correct operating position. Pull the hand-brake lever back through three clicks.

From the pit:

- Remove the lower engine guard. Slacken nut

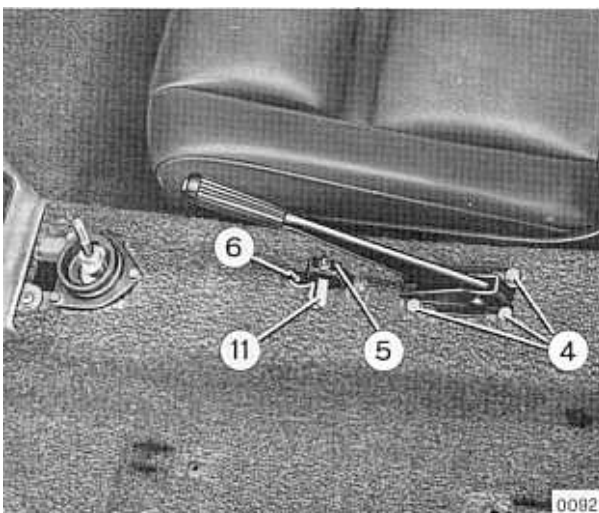

Fig. 09 2/3 - Removal of hand-brake cable

- Unscrew the bolts (4) holding the hand-brake lever to the tunnel.

(1) and its lock nut (2). Turn the stretcher (3) by means of its hexagonal end until the wheels are locked, then retighten the nut (1) and lock nut (2).

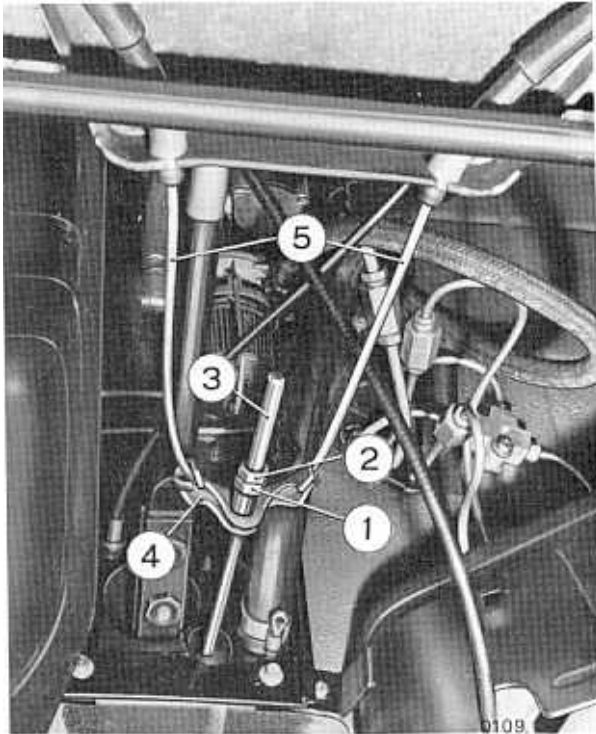

Fig. 09 2/5 - Hand-brake linkage

From inside the vehicle:

- Work the hand-brake lever hard several times. Check that the rear wheels are locked when the lever makes its third click, and free to turn when the lever is fully released.

§ 09 2 1700

REMOVAL AND REFITTING OF THE BRAKE PUMP (not including removal and refitting of pedal support)

Remove pedal support as described at para. 12 2 1400 and *proceed as follows*:

Removal

- Mount the pedal support in a vice. Fit tool 88023032 and detach clutch pedal return spring (1). Unscrew unions (10) and (11) and take off their respective pipes.

- Unscrew the two bolts holding the pump guard (12) and take off the guard; unscrew the bolts (5) holding the pump to the support and slide the pump from its compartment.

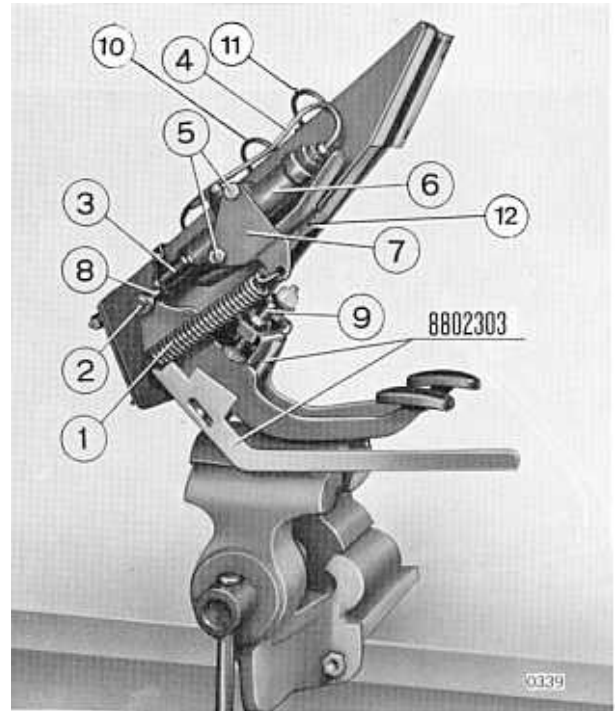

Fig. 09 2/6 - Pedal support assembly

Refitting

- Refit in the reverse order and tighten parts (5) to the correct torque loading. On completion, bleed the hydraulic circuits as described at para 09 2 5300.

TOOL REQUIRED

- 88023032 - Tool for dismounting and remounting clutch pedal return spring

§ 09 2 1800

REMOVAL AND REFITTING OF THE SERVO UNIT (not including bleeding the air circuit)

Stand the vehicle over the pit and *proceed as follows*:

- From the pit, remove the dust cover, pipe (8) from the union, and vacuum hose (7) from the

servo 6. Unscrew the three nuts 5 holding the servo on the bracket of the support and slide off the support.

Remove pipe 9 from the union and take off the servo.

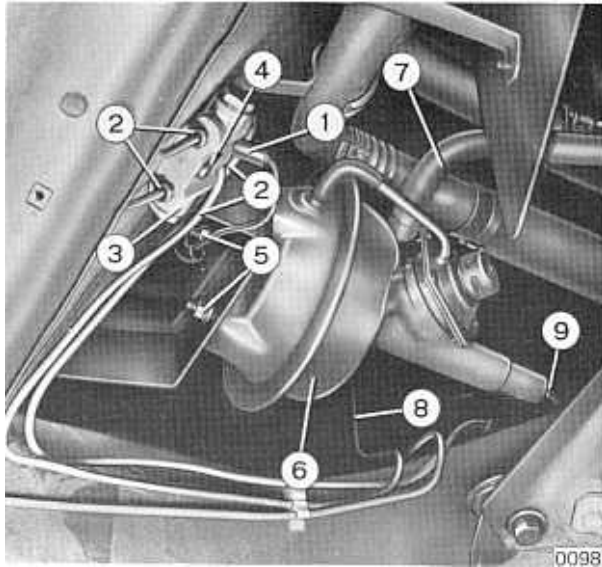

Fig. 09 2/7 - Servo unit and brake fluid pressure drop indicator

Refitting

Remount the new servo in the reverse order and bleed the brake circuit as described at para 09 2 5300.

TOOL REQUIRED

– 88051006 - Spanner for brake pipe unions

§ 09 2 1840

REMOVAL AND REFITTING OF BRAKE FLUID PRESSURE DROP INDICATOR (not including bleeding the circuit) (*)

Stand the vehicle over the pit and *proceed as follows*:

Removal

– For refs. see fig. 09 2/7.

– From the pit, remove the dust apron, electrical lead (1) and the four brake fluid pipe unions (2). Collect the fluid. Unscrew bolt (4) and take off the indicator (3).

Refitting

– Remount the new indicator in the reverse order and tighten the four unions (2).

(*) Bleeding the brake circuit is described at para 09 2 5300.

§ 09 2 2200

REMOVAL, ADJUSTMENT AND REFITTING OF THE BRAKE PEDAL (not including removal and refitting of the pedal support)

Remove pedal support as described at para 12 2 1400 and *proceed as follows*:

Removal

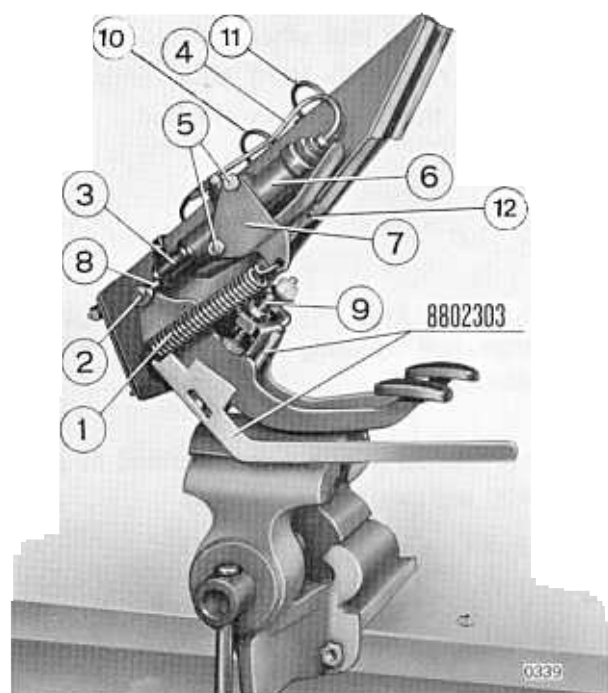
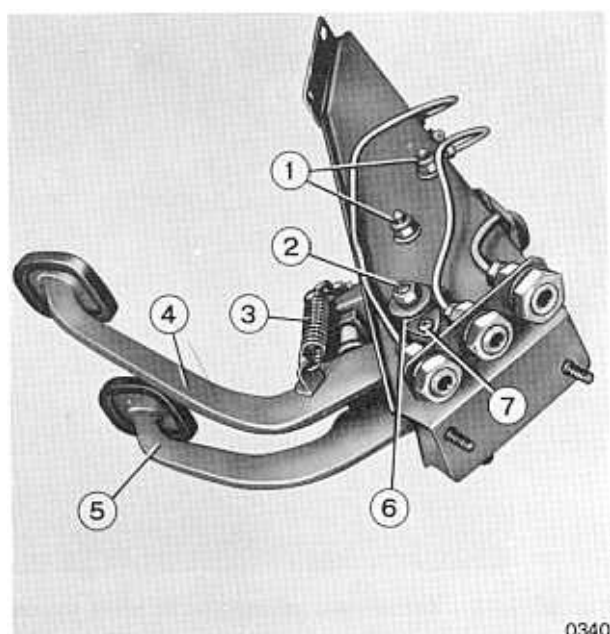

Fig. 09 2/8 - Servo unit and brake fluid pressure drop indicator.

- Mount the pedal support in a vice. Unscrew the pipe unions and take off the pipe (4). Remove the split pin (2) holding the clutch pedal. Fit tool 88023032 as shown in fig. 09 2/9 and take off the spring (1). Unscrew the bolts (5) holding the bracket (7) and the pump (6). Slide the pump from its compartment.



- Fig. 09 2/9 - Pedal support, complete with controls

- Unscrew the nut (2) holding pedals (4) and (5) and bolt (7).
- Slide off the bush (6) and the two pedals. Unhook the spring (3). Take out the split pin holding the brake pedal tip. Unscrew the stop lights switch.
- Check all disassembled parts for wear and renew as required.

Refitting

- Refit in the reverse order. Tighten nut (2) to the correct torque loading.
- After remounting the support as described at para. 12 2 1400, bleed the hydraulic circuits, as described at para. 09 2 5300. On completion, check that the brake pump

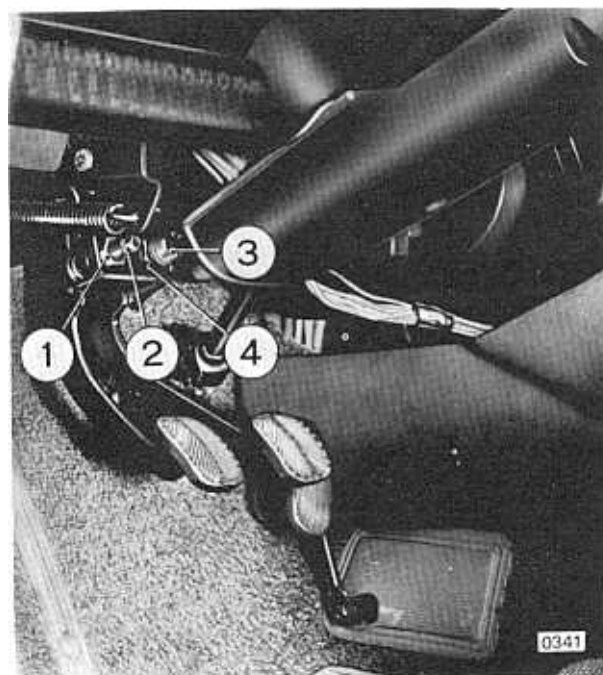

Fig. 09 2/10 - Pedal assembly

piston is touching the stop screw to give a pedal play distance of about 1.62 mm. Then tighten the switch (3) until it reaches the brake pedal. This pedal is about 15 mm lower than the clutch pedal. Lastly, check that the stop lights are off when the brake pedal is at rest.

TOOLS REQUIRED

- 88023032 - Tool for dismounting and remounting clutch pedal return spring.

§ 09 2 3700

REMOVAL AND REFITTING OF A FRONT OR REAR BRAKE CALIPER (not including bleeding the circuit)

Stand the vehicle over the pit, fit covers

88083051 and *proceed as follows*:

Removal

- Slacken the stud bolts of the wheel concerned and lift the vehicle up from inside the pit and rest it on trestles.
- Take off the wheel. Remove the pin (5), unscrew the hose (7) from the union (6) and collect the brake fluid.

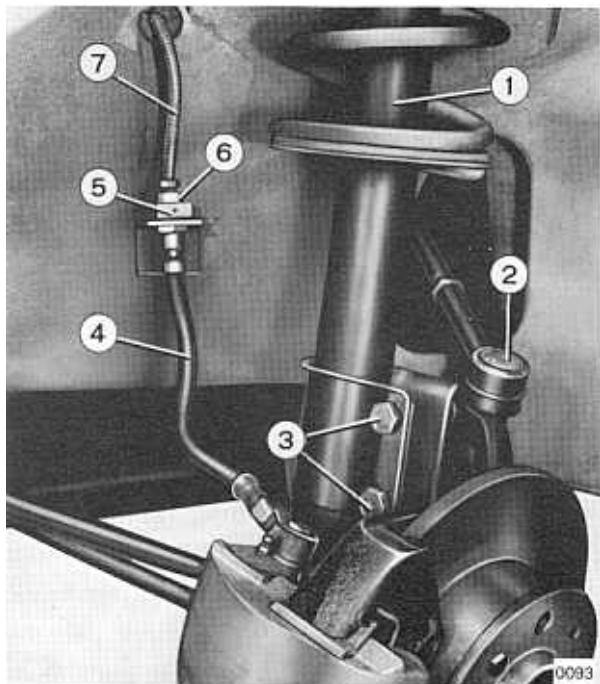

Fig. 09 2/11 - Front suspension and brake fluid hose

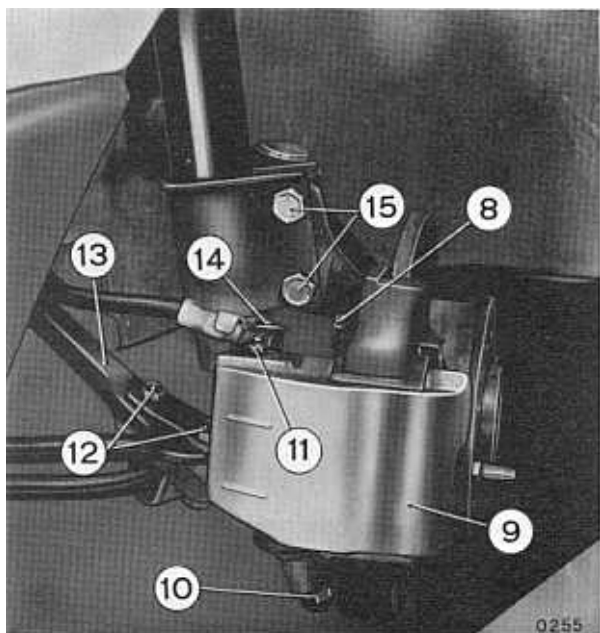

Fig. 09 2/12 - Front suspension and brake caliper

- Unscrew bolts (8) and withdraw the caliper and centering shim.
- Clean the caliper body and swivel carefully with paraffin. Inspect all disassembled parts for damage and renew as necessary.

Note: removal of the rear brake caliper also requires the detachment of the hand-brake cable from the lever (ref. 2).

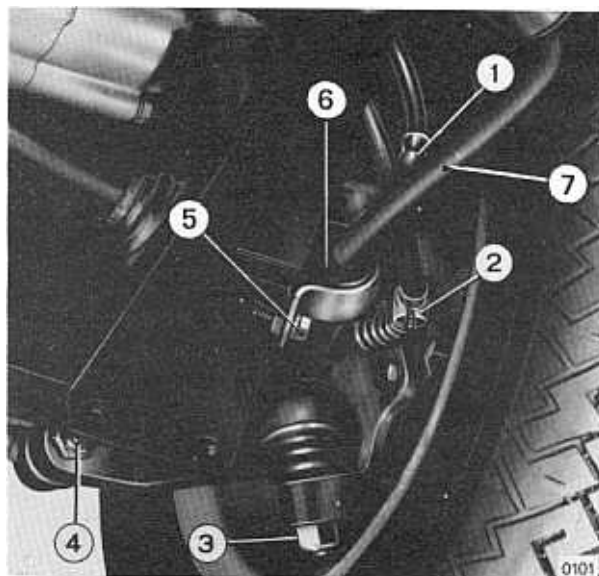

Fig. 09 2/13 - Attachment of hand-brake cable to rear caliper

Refitting

- Reassemble in the reverse order. Lock bolts (8) to the torque loadings shown in DT. Bleed the circuit as described at para 09 2 5300 and check the effective operation of the hand-brake when refitting a rear caliper.

§ 09 2 4100

REMOVAL AND REFITTING OF A BRAKE CALIPER CARRIER

Stand the vehicle over the pit and *proceed as follows*:

Removal

- Slacken the stud bolts of the wheel concerned

and lift the vehicle up from inside the pit and rest it on trestles.

- Take off the wheel and follow the sequence of operations shown in the photos below. Collect the brake fluid.

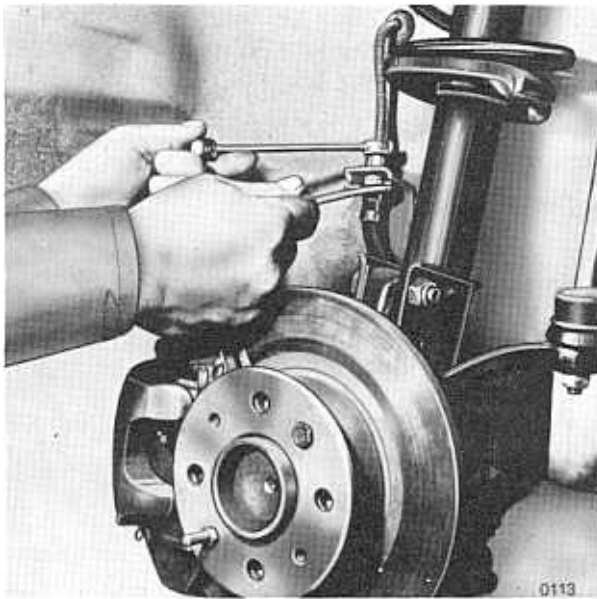

Fig. 09 2/14 - Removal of brake fluid hose from union

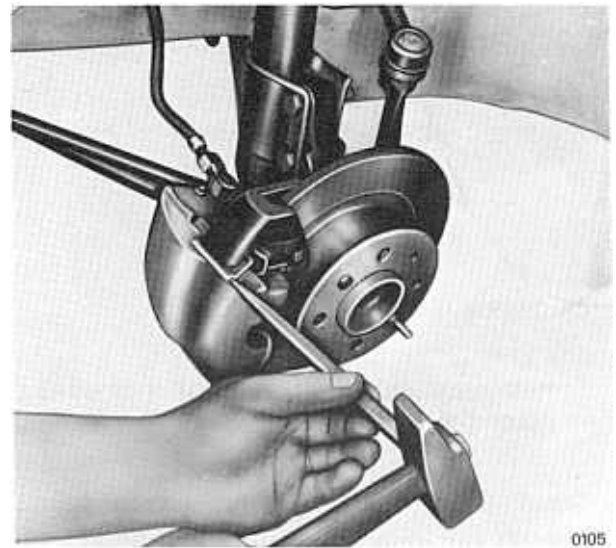

Fig. 09 2/16 - Removal of retainer pad

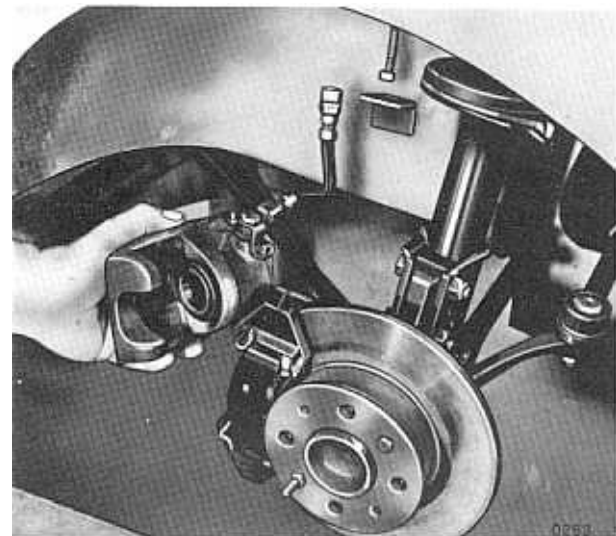

Fig. 09 2/17 - Front caliper carrier

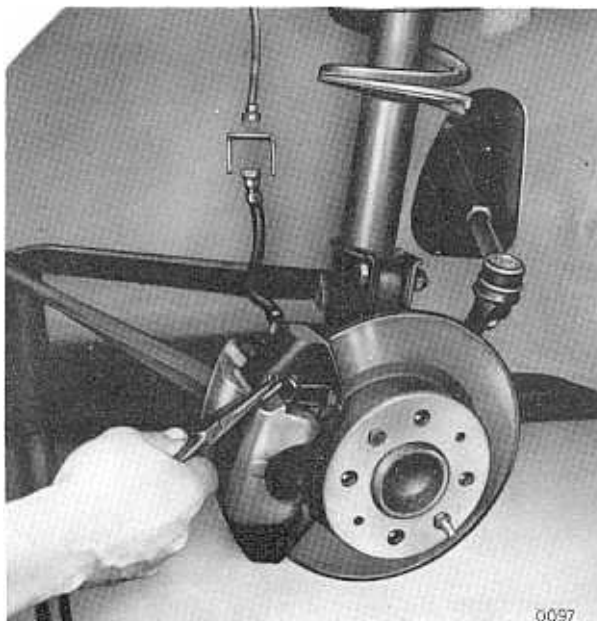

Fig. 09 2/15 Withdrawal of friction pads cotter

Note: removal of a rear carrier also requires the detachment of the hand-brake cable from the lever (ref. 2 in fig. 09 2/13) and disconnection of the fluid hose from the caliper instead of the underbody bracket. Overhaul of the carrier is described at para. 09 4 0800 & 1000

Refitting

- Refit in the reverse order. Bleed the circuit involved as described at para 09 2 5300, and

check the effectiveness of the hand-brake when refitting a rear caliper carrier (1).

(1) Adjustment of the hand-brake is described at para 09 2 1300.

§ 09 2 4500

REMOVAL AND REFITTING OF THE BRAKE DISCS

Stand the vehicle over the pit, fit covers 88088051 and *proceed as follows*:

Removal

- Slacken the wheel stud bolts and lift the vehicle up from inside the pit and rest it on trestles. Remove the wheels and brake calipers (without disconnecting the pipes) and fix them to one side.
- Unscrew bolts (5), take off the spacer (4) and withdraw the disc (1).

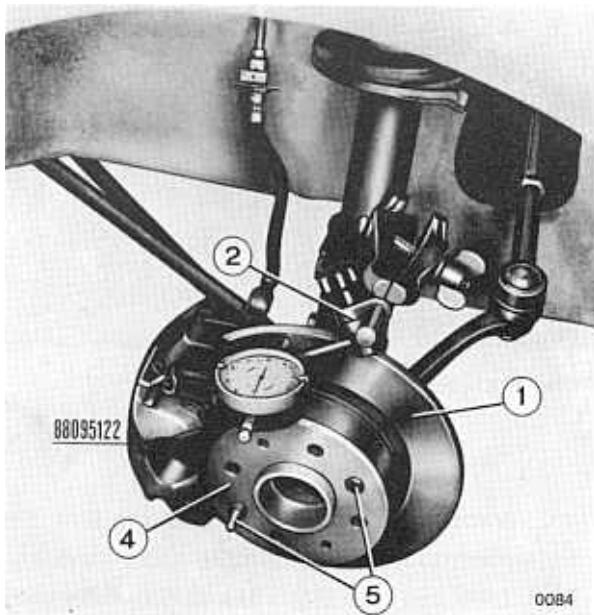

Fig. 09 2/18 - Front brake disc

Note: refacing or renewal of the discs must be done in pairs (Front or rear) in accordance with DT-Beta Montecarlo 09/0040.

- Disc alignment is described at para 09 2 4600.

Refitting

- Refit in the reverse order. Wash the disc in methylated spirit and lock bolts (5) to the correct torque loading.

§ 09 2 4600

CHECKING THE ALIGNMENT OF THE FRONT OR REAR BRAKE DISCS (see fig. 09 2/19)

Stand the vehicle over the pit and *proceed as follows*:

Removal

- Slacken the wheel stud bolts. Jack the vehicle onto trestles and take off the wheels.
- Front wheels: set gauge as shown in fig. 09 2/18 to check that the discs are at right angles to the axis of rotation.
- Rear wheels: mount the gauge on stand 88095768 and set it firmly on the floor.
- Clean the disc surface with methylated spirit. When the gauge is 2 mm from the outside diameter of the disc, the maximum off-centre value given in DT.

should be complied with, if necessary by grinding the two discs to the thickness values shown on the same data sheet.

Refitting

- Reassemble in the reverse order. If a disc has been refaced or renewed, tighten bolts (5) to the correct torque loading.

TOOLS REQUIRED

- 88095122 - Centesimal dial gauge
- 88095768 - Stand for gauge

§ 09 2 4900

RENEWAL OF BRAKE FRICTION PADS

N.B. – This operation must be carried out when the minimum thickness value shown in DT-Beta Montecarlo 09/0040 as reached.

Stand the vehicle over the pit and *proceed as follows*:

Removal

- Slacken the wheel stud bolts. Jack the vehicle onto trestles and take off the wheels.
- Renew the friction pads as shown in the photos below.

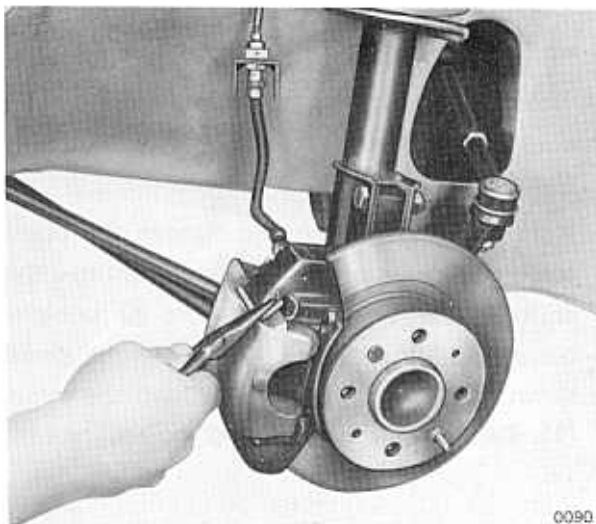

Fig. 09 2/19 - Checking the angle of the front brake disc to the axis of rotation

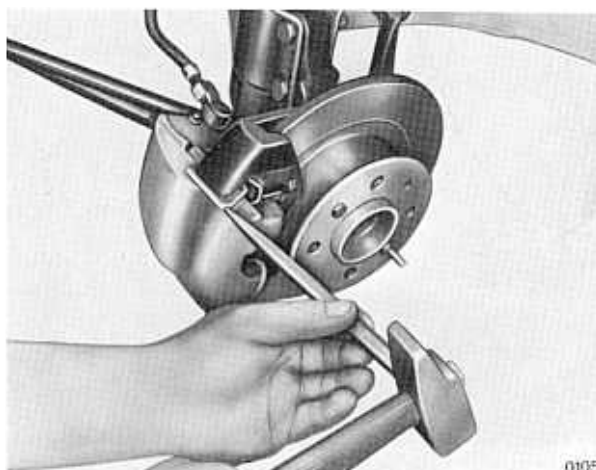

Fig. 09 2/20 - Removal of retainer pad

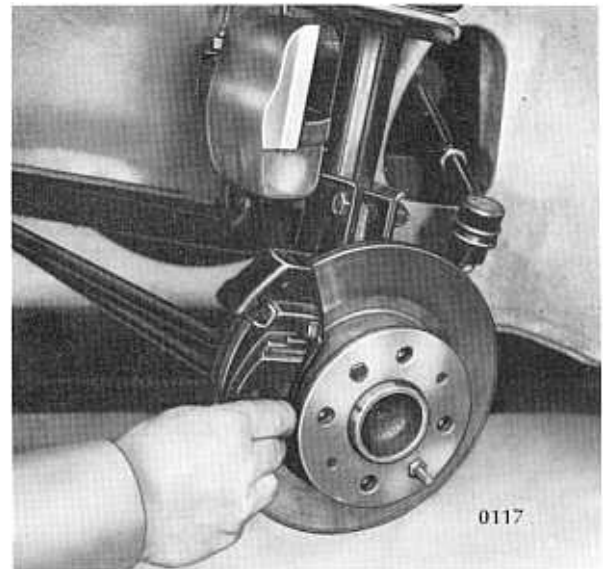

Fig. 09 2/21 - Caliper carrier and friction pad

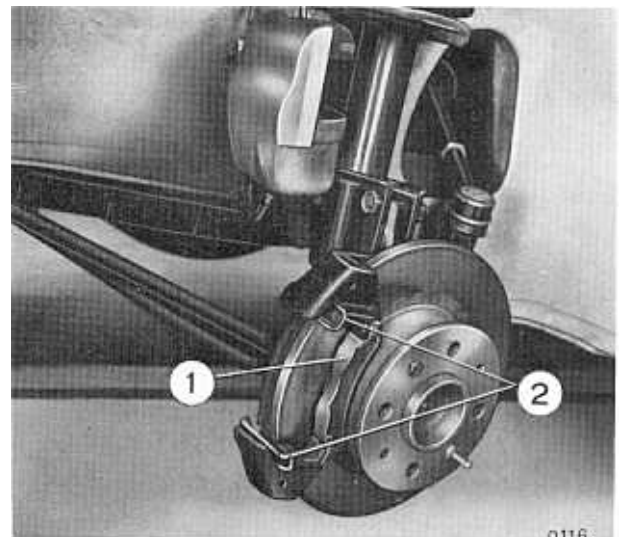

Fig. 09 2/22 - Caliper and spring for pads

Refitting

- Clean the disc thoroughly with methylated spirits.
- Reinsert the pistons in the cylinders. In the case of the rear calipers, the pistons must be turned clockwise.
- Refit in the reverse order. On completion, move the brake pedal up and down and check that it is working properly.

§ 09 2 4910

RENEWAL OF FRONT OR REAR CALIPER
CARRIER SPRINGS

Stand the vehicle over the pit and *proceed as*

follows:

- Remove the friction pads as described in para. 09 2 4900.
- Compress the carrier springs (2) and detach them from the caliper.

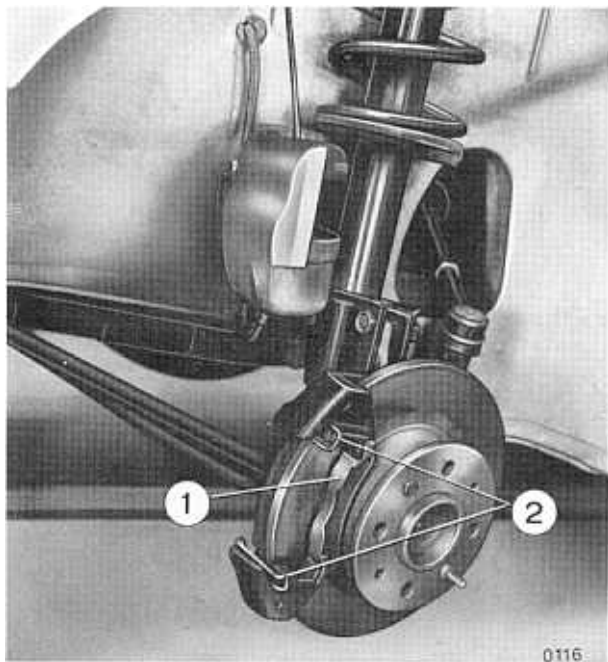

Fig. 09 2/23 - Renewal of caliper carrier springs

Refitting

- Clean the caliper components with alcohol. Mount new springs in the carrier and refit all parts in the reverse order. On completion, check that the brake is working properly.

Note: the position of the springs is shown in fig. 09 2/23.

§ 09 2 5300

BLEEDING THE HYDRAULIC BRAKE CIRCUITS

Note: Use only fresh brake fluid of the type specified in DT-Beta Montecarlo 17/0010 when refilling or topping up the system.

Stand the vehicle over the pit, fit covers 88083056 and *proceed as follows:*

- Fill the two reservoirs with the correct type of fluid and pump it through the circuits with the brake pedal. Top up the reservoir as required and carry on pumping till the level remains constant.

N.B. – When filling and bleeding the circuits, make sure that the fluid does not go below the “empty” level in the reservoir, since this would result in letting air into the system.

- Clean all traces of mud and dust from the end of the bleed union and take off the cap. Fit one end of a 30-40 cm flexible hose made of transparent rubber on the screw (1) and insert the other end in a container partly filled with brake fluid.
- The first section of the hose should run upwards, as shown in fig. 09 2/25.
- Press the brake pedal down quickly and slacken the bleed screw (1). A mixture of fluid and air will pass up the hose.
- Hold the pedal down and tighten the bleed screw. Release the pedal slowly. Continue the entire operation until no more air bubbles come out of the hose (2). Hold the pedal down for the last time and tighten the screw (1). Take off the hose (2) and replace the cap.

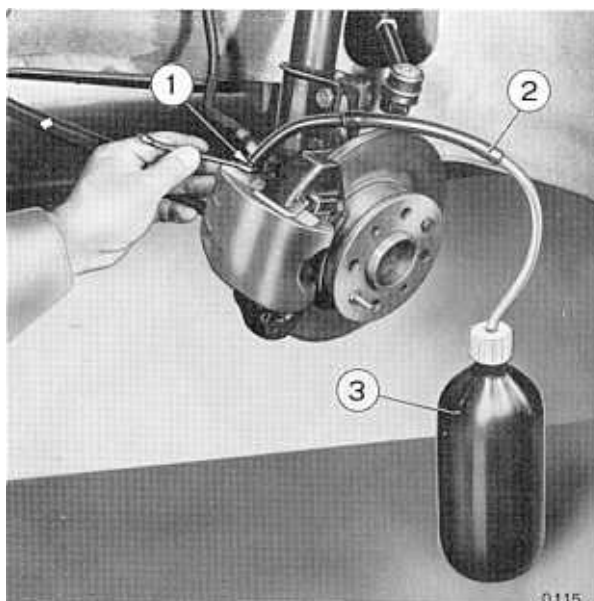

Fig. 09 2/24 - Bleeding air from the front wheel brake system circuit.

- Repeat these operations on the other brake calipers. On each occasion, make sure that there is enough fluid in the reservoir.
- If a certain degree of sponginess remains when the brake pedal is pressed down after all four circuits have been bled, the entire operation will have to be repeated on the four bleed screws.

- Top up the reservoirs if necessary.
- Work the brake pedal at its normal braking force for 2-3 min and check the entire system for leaks.

TOOLS REQUIRED

- 88083051 - Covers
- 88083056

CHAPTER 4

§ 09 4 0100

OVERHAUL OF THE MASTER CYLINDER (not including removal and refitting the pedal assembly)

Remove the cylinder as described at para. 09 2 1700 and *proceed as follows*:

Removal

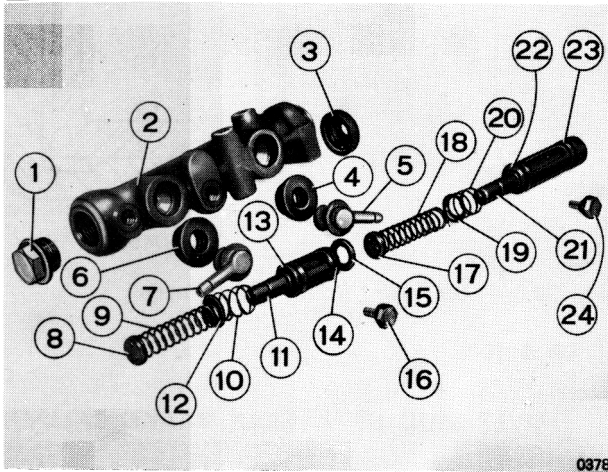

Fig. 09 4/1 - Master cylinder

– Mount the cylinder in a lead-jawed vice. Remove connections (4) and (6) and pipe unions (5) and (7). Unscrew the stop screws (16) and (24), the locking plug and washer (1) and the guard (3).

- From inside the body: take out the piston return spring (9), the cup (12), the spring (10), the cylinder seal (13), the spacer (26), the piston (11), the floating spacer (8), the washer (15), the piston return spring (18), the cup (19), the spring (20), the seal (22), the spacer (25), the piston (21) and the seal (23).
- Check that the pistons slide freely in the cylinder and that the inside of the pump body and the outside of the pistons have a shiny surface and are free from scratches, etc.
- Replace if necessary.

Refitting

- Reassemble the pistons. Renew the seals if necessary. Replace the front circuit parts in the cylinder in the reverse order. Tighten the piston by means of bolt (24) and repeat these operations for the back cylinder.
- On completion, check that the cylinder and its circuits work properly and bleed the braking system (1)

(1) Bench testing of the master cylinder is dealt with at para 16.4.5500.

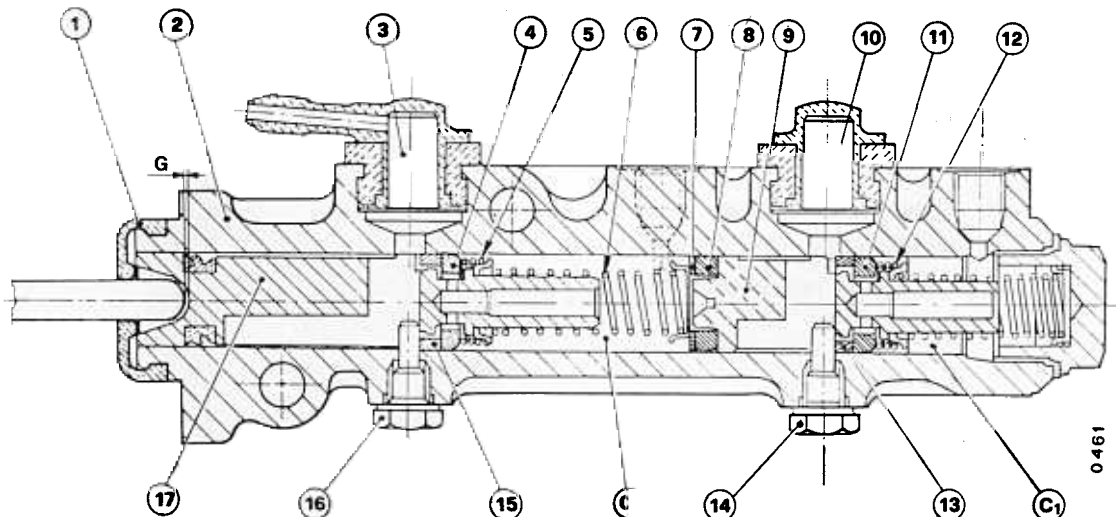

Fig. 09 4/2 - Section of master cylinder

§ 09 4 0800

OVERHAUL OF A FRONT BRAKE CALIPER CARRIER

Note: caliper components must be washed in hot water only. Other substances, such as petrol, diesel oil, trichloroethylene or mineral solvents, will damage the seals.

Disassembly

Fig. 09 4/3 - Front brake caliper parts

Remove the carrier as described at para 09 2 4100. Unscrew the bleed screw (6) and take off the dust guard (9). Blow the piston (8) out of the cylinder (5) by directing a jet of compressed air into the brake fluid union.

Remove the seal (7) from its seat (10). Be careful not to scratch the piston seating.

- Check that the piston and cylinder are free from signs of abrasion and binding. If not, the caliper and piston must be renewed together.

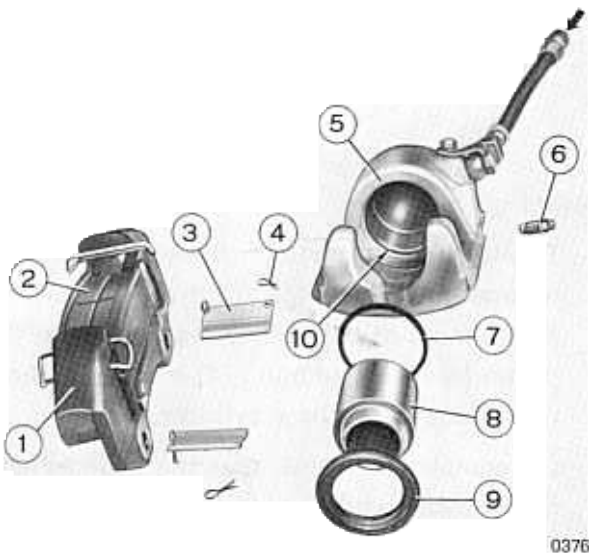
Reassembly

- Check and replace as required, then reassemble the calipers as follows:
- Fit the seal (7) into its seat (10) on the cylinder. Slide the piston (8) as far as it will go into the cylinder (5).

- Lubricate the seat of the dust guard with SP 349 grease where marked (*). Mount the guard and check that its edge fits properly into the groove on the carrier.

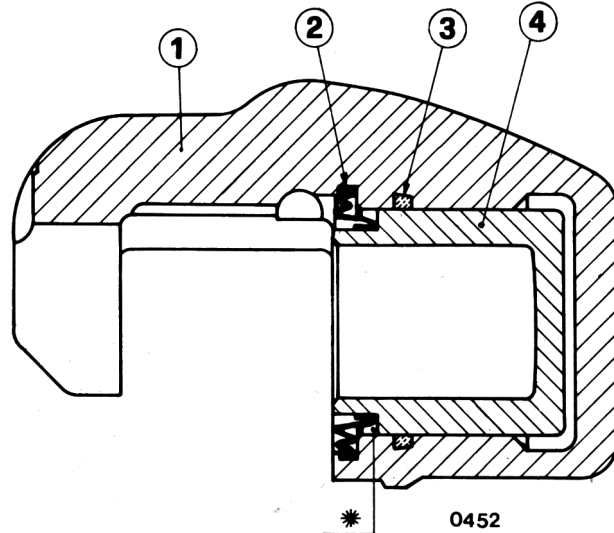

Fig. 09 4/4 - Section of front brake caliper

§ 09 4 1000

OVERHAUL OF A REAR BRAKE CALIPER CARRIER

Note: caliper components must be washed in hot water only. Other substances, such as petrol, diesel oil, trichloroethylene, or mineral solvents, will damage the seals.

Disassembly

- Remove the carrier as described at para. 09 2 4100 and mount it in a lead-jawed vice. Remove the dust guard (3), unscrew the cylinder and use a jet of compressed air through the brake fluid port to drive out the

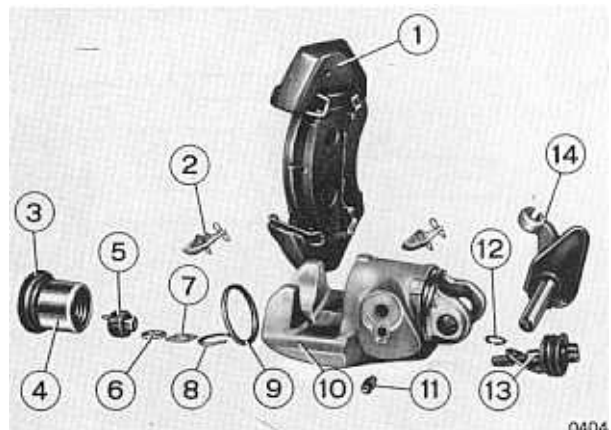

Fig. 09 4/5 - Rear brake caliper parts

- piston (4) and to remove the seal (9) from its seat and the bleed screw (11).
- Remove the circlip (8) and slide off the spacer (7) and the bearing (6).
- Remove the circlip (12) and take off the hand brake lever (14). Unscrew the self-regulating screw (13) from the female thread together with the spring (5).

Overhaul

- Clean all disassembled parts with methylated spirit, particularly the seal housings. Use a soft brush or a paint brush for this purpose. Blow dry with compressed air.
- Check that the piston and cylinder are free from signs of abrasion and binding. If not, the caliper and piston must be renewed together. Renew worn or damaged parts as necessary.

Reassembly

Note: lubricate all metal parts and the seals with brake fluid. Apply grease SP 349 to the seat where marked (*), as well as to the points of contact between the hand brake lever and the self-regulating pin.

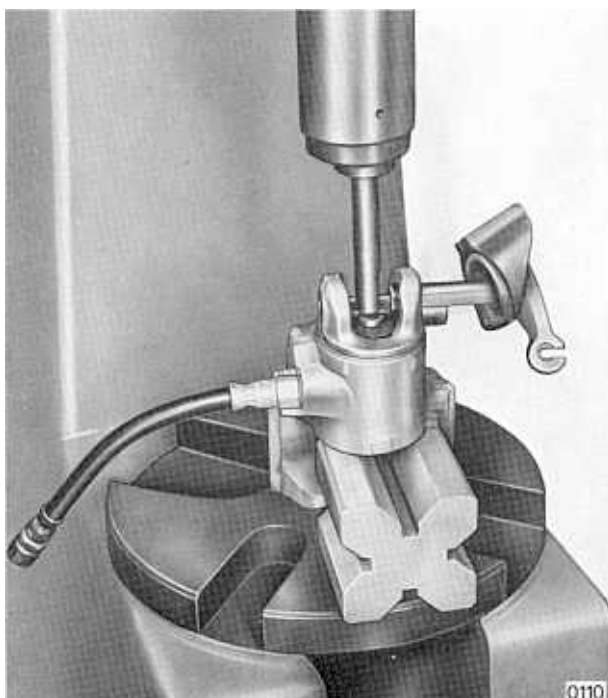

Fig. 09 4/6 - Tool for mounting the rear brake calipers hand brake control pin

- Reassemble the caliper in the reverse order. Use tool 88053067 as shown in the photo below to insert the hand brake lever (14) on the self-regulating screw (13) into the cylinder body.
- On completion, screw down the piston as far as it will go to open the friction pads as much as possible. Check that the notch on the piston is upright.

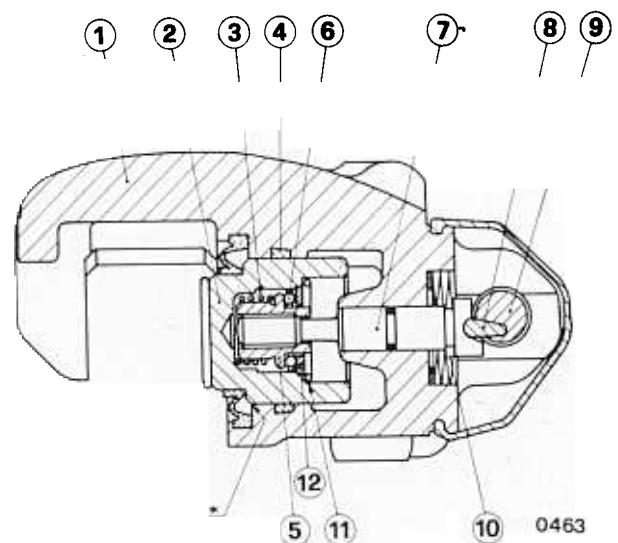

Fig. 09 4/7 - Section of rear brake caliper

TOOL REQUIRED

- 88053067 - Tool for mounting the rear brake calipers hand brake control pin.

§ 09 4 1600

OVERHAUL OF THE HAND BRAKE CONTROL

Proceed as follows:

Disassembly

- Slide off the circlip (1) and the lever mounting pin (2).
- Remove the lever (10) from its support (3). Unscrew the button (3) and free the washer (8), pipe (7), sliding rod (5) and return spring

(6), and the toothed sector (4).

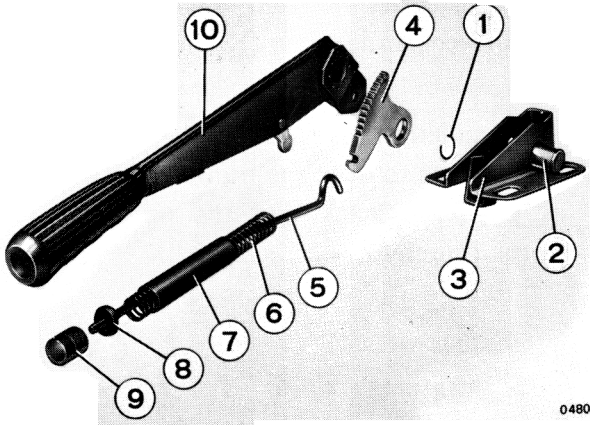

Fig. 09 4/8 - Hand brake lever

Overhaul

Check all parts and renew as necessary if worn or damaged.

Reassembly

- Reassemble in the reverse order. Grease the toothed sector.
- On completion, check that the sector and sliding rod work properly.

SEC 10

Air System

Air compressors - Tanks - Valves - Pipes - Units

(Not Fitted to This Vehicle)

SEC 11

Frame

Frame or subframes for mechanical assemblies

(Not Fitted to This Vehicle)

BASIC MODEL

The directions and operations refer to the steering components fitted to all car models.

STEERING GROUP CONTENTS

CHAPTER 1

Troubles, probable causes, checkings and operations to be carried out

from page 12 1/1

to page 12 1/3

CHAPTER 2

§ 12 2 1000	Removal and refitting of the steering wheel	page 2 2/1
§ 12 2 1300	Removal and refitting of jointed steering column jacket	" 2 2/1
§ 12 2 1400	Removal and refitting of pedal support assembly	" 2 2/1
§ 12 2 1600	Removal and refitting of jointed steering column from and on its jacket	" 2 2/2
§ 12 2 1700	Renewal of jointed section of steering column	" 2 2/2
§ 12 2 1900	Removal and refitting the anti-theft steering wheel lock	" 2 2/3
§ 12 2 2500	Removal and refitting of rack housing	" 2 2/3
§ 12 2 3900	Renewal of a (right, or left) steering rod ball joint	" 2 2/4
§ 12 2 4000	Removing and refitting a swivel	" 2 2/5

CHAPTER 4

§ 12 4 0300	Overhaul of rack housing	page 12 4/1
-------------	--------------------------	-------------

FAULT	PROBABLE CAUSES	CHECKS ADVISABLE BEFORE REPAIRING	ACTION NECESSARY	PARA
Vehicle pulls to the right or left	Differences in tire pressure	—	Correct tire pressures	
	Worn swivels or suspension arms	—	Check wheel geometry with optical equipment Removal and refitting of swivels Removal and refitting of suspension arms	12 2 0010 12 2 4000 07 2 0700
	Distorted rear suspension transverse link	—	Check wheel geometry with optical equipment Removal and refitting of rear suspension transverse link	12 2 0010 07 2 0700
Poor road holding	Incorrect tire pressures	—	Correct tire pressures	
	Incorrect front wheel geometry	—	Check wheel geometry with optical equipment	12 2 0010
	Inefficient front or rear shock absorbers	—	Removal and refitting the front suspension Removal and refitting the rear suspension Disassembly and reassembly of a front suspension Disassembly and reassembly of a rear suspension	07 2 0700 07 2 2400 07 4 1000 07 4 1100

FAULT	PROBABLE CAUSES	CHECKS ADVISABLE BEFORE REPAIRING	ACTION NECESSARY	PARA
Excessive steering wheel play or vibration	Too much play in steering rod ball joints, or worn steering rod silent blocks	—	Removal and refitting of steering rod ball joints Removal and refitting of steering rack housing Overhaul of rack housing	12 2 3900 12 2 2500 12 4 0300
	Rack locating support worn, or fatigue in locating spring	—	Removal and refitting of steering rack housing Overhaul of rack housing	12 2 2300 12 4 0300
Slow return to the straight-ahead position	Front suspension strut thrust bearings poorly lubricated or worn	—	Removal and refitting of a front suspension Disassembly and reassembly of a front suspension	07 2 0700 07 4 1000
	Rack housing insufficiently lubricated	Check for oil leaks at the cap seals	Removal and refitting of the rack housing Overhaul of the rack housing	12 2 2500 12 4 0300
	Worn steering rod ball joints	—	Renewal of steering rod ball joints	12 2 3900
Front wheel shimmy transmitted to the steering wheel	Front wheels off balance	Check whether shimmy occurs at a definite speed when driving straight	Balancing of front wheels off the vehicle with the CEMB balancer	08 4 0900

FAULT	PROBABLE CAUSES	CHECKS ADVISABLE BEFORE REPAIRING	ACTION NECESSARY	PARA
Diameter of turning circle not as specified, or unequal in either direction	Incorrect steering geometry	-	Check wheel geometry with optical equipment	12 2 0010

CHAPTER 2

§ 12 2 1000

REMOVAL AND REFITTING OF THE STEERING WHEEL

Fit covers 88083058 and *proceed as follows*:

Removal

- Disconnect the positive battery lead. Enter the vehicle and set the front wheels in the straight-ahead position.
- Take off the horn control and its spring. Unscrew the nut holding the steering wheel and make reference marks on both the steering wheel and the steering column.
- Remove the steering wheel.

Refitting

- Refit the steering wheel with its spokes horizontal. Tighten the nut to the correct torque loading.
- Refit the remaining parts in the reverse order.

§ 12 2 1300

REMOVAL AND REFITTING OF JOINTED STEERING COLUMN JACKET

Fit covers 88083051 and 88083056 and *proceed as follows*:

Removal

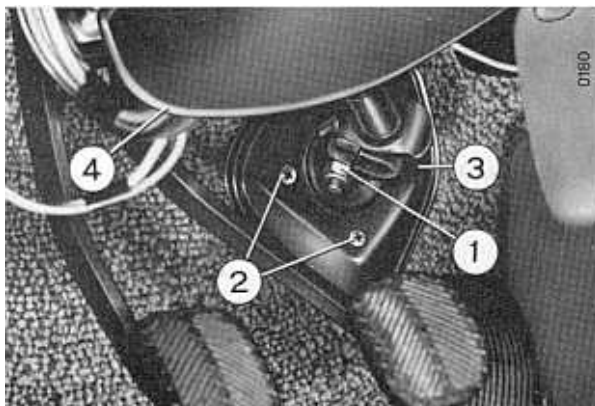

Fig. 12 2/1 - Connection between jointed steering column and rack housing worm

- Disconnect the positive battery lead
- Unscrew the bolts holding the guard (4) and take it off.
- Take the multiple electrical plug out of its socket.
- Set the front wheels in the straight-ahead position. Unscrew nut (1) and detach the steering column from the rack housing worm.
- Unscrew the nuts and bolts holding the jacket to the body and remove it; complete with the controls and the steering wheel.

Refitting

- With the front wheels pointing straight ahead and the spokes of the steering wheel horizontal, refit all parts in the reverse order.
- Reconnect the battery lead and check that all electrical parts are in working order.

§ 12 2 1400

REMOVAL AND REFITTING OF PEDAL SUPPORT ASSEMBLY (not including removal and refitting of jointed steering column jacket, or bleeding the brake and friction circuits)

Remove the jointed steering column jacket as described at para. 12 2 1300 and *proceed as follows*:

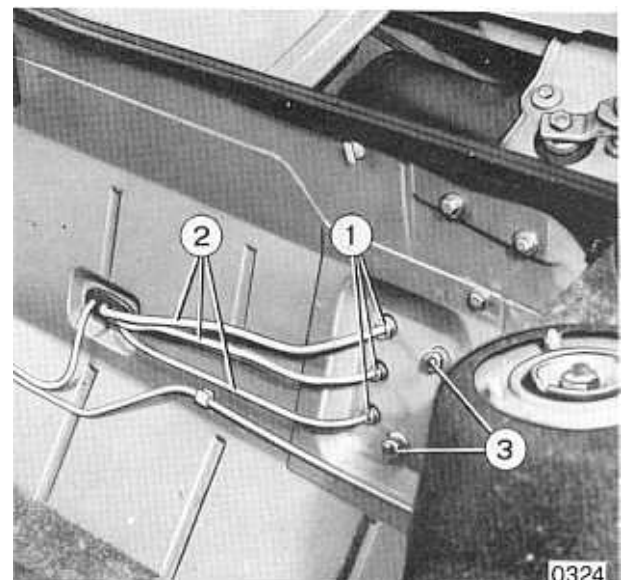

Fig. 12 2/2 - Brake and clutch pipes

Removal

- Working from the boot, unscrew the brake and clutch circuit reservoirs and draw off the fluid with a syringe.
- Take out the carpet. Place a guard under the unions (1) to protect the paint from the fluid that will come out of the pipes and the pump.
- Unscrew the unions (1), slip off the pipes (2) and unscrew the nuts (3).
- From inside the vehicle, lower the pedal support, loosen the clamps and disconnect the hoses from the pumps. Detach the brake light switch leads. Remove the support, complete with pedals.

Refitting

- Refit the pedal support in the reverse order. On completion, bleed the brake and clutch hydraulic circuits as described at paras. 09 2 5300 & 02 2 1900.

§ 12 2 1600

REMOVAL AND REFITTING OF JOINTED STEERING COLUMN FROM AND ON ITS JACKET

Remove the jointed steering column jacket as described at para. 12 2 1300 and *proceed as follows*:

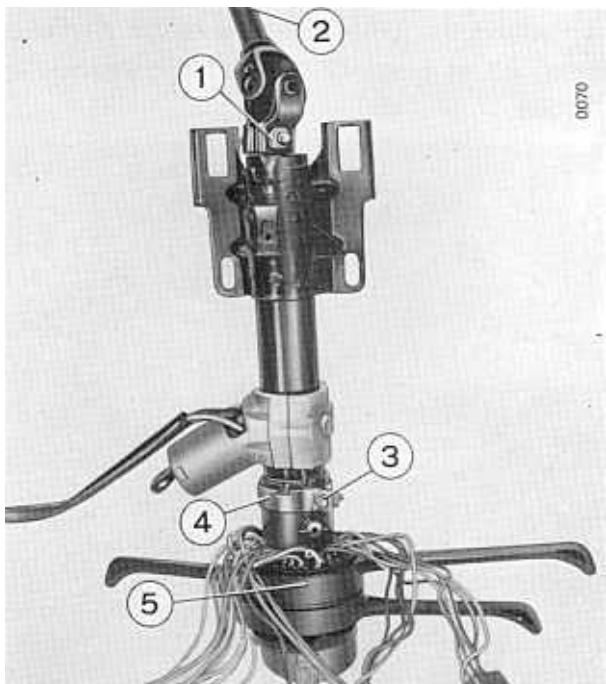

Fig. 12 2/3 - Jointed steering column complete with jacket

At the bench**Disassembly:**

- Take off the horn-push and its spring
- Unscrew the nut holding the steering wheel to the column.
- It is advisable to make a reference mark showing the position of the column with respect to the wheel, since this will make reassembly easier. Take off the steering wheel.
- Unscrew the bolt (1) and slide off the column (2). Slacken bolt (3) of the collar (4) and take off the control assembly (5).

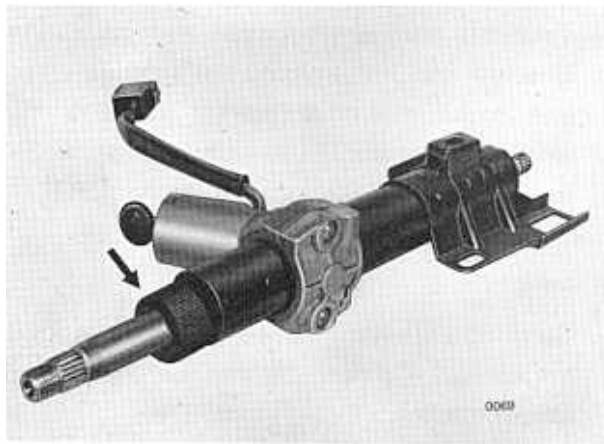

Fig. 12 2/4 - Steering column jacket

- Drive the column, complete with the top bushing, off the jacket by tapping it with a rawhide mallet.
- Check all parts for wear or damage and renew as required.

Reassembly

- Mount the bottom bushing on the column and recrimp it. Reassemble the remaining parts in the reverse order. Tighten all nuts and bolts to the correct torque loading.

§ 12 2 1700

RENEWAL OF JOINTED SECTION OF STEERING COLUMN

Fit covers 88083056 and *proceed as follows*:

- From inside the vehicle, unscrew the screws and take off the lower casing.

- Set the front wheels in the straight-ahead position. Unscrew the nut holding the jointed section to the rack housing worm and take off the section
- Unscrew the nut holding the upper jointed section to the upper shaft and take off the section.

Refitting

- Refit in the reverse order and tighten the nuts to the correct torque loading.

§ 12 2 1900

REMOVAL AND REFITTING OF ANTI-THEFT STEERING WHEEL LOCK

Remove the jointed steering column jacket as described at para. 12 2 1300 and *proceed as follows*:

Removal

- Use pillar drill 88096828 and a 6 mm drill to bore and remove the bolts holding the device to the jacket.
- Unscrew the bolts with a square-tipped punch and remove the device.

Refitting

- Bolt the anti-theft device to the steering column jacket. The bolts must be tightened till their heads snap off.
- Refit the jointed steering column jacket as described at para. 12 2 1300.

TOOLS REQUIRED

- Square-tipped punch
- 88096828 - Pillar drill

§ 12 2 2500

REMOVAL AND REFITTING OF RACK HOUSING

Stand the vehicle over the pit, fit covers

88083051 and *proceed as follows*:

Removal



Fig. 12 2/5 - Position of front:

- Slacken the bolts holding the front wheels.
- From the pit, raise the front of the vehicle with a pillar lift fitted with a crosspiece, as shown in fig.

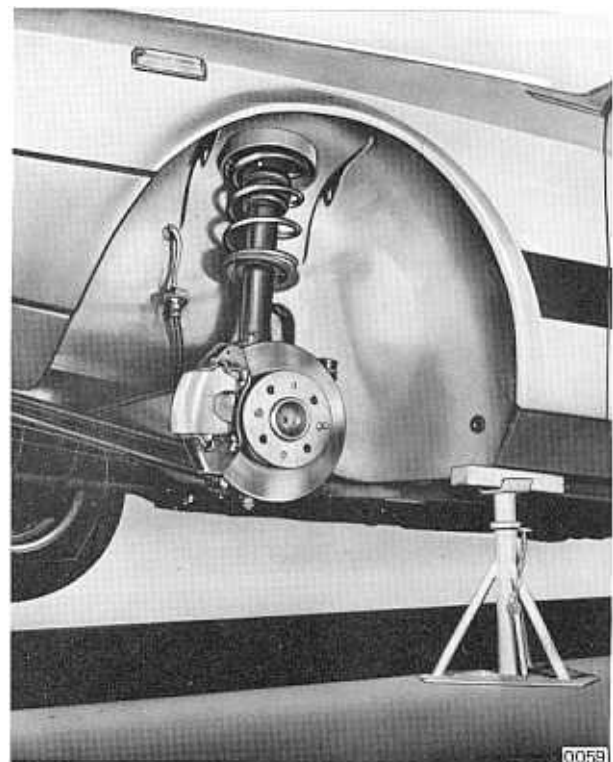

Fig. 12 2/6 - Position of stands 88097120

- Set stands 88097120 as shown in fig. 12 2/6. Lower the vehicle onto the stands and take off the front wheels

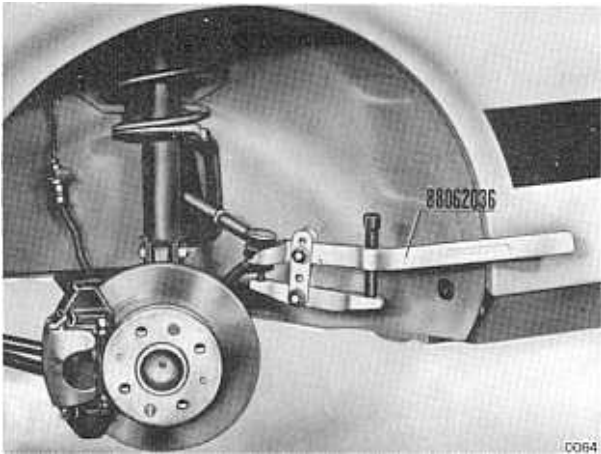

Fig. 12 2/7 - Use of tool 88062036 to drive off ball joint

- Unscrew the bolts holding the ball joints to the swivel and use tool 88062036 to drive the joints from the swivels.

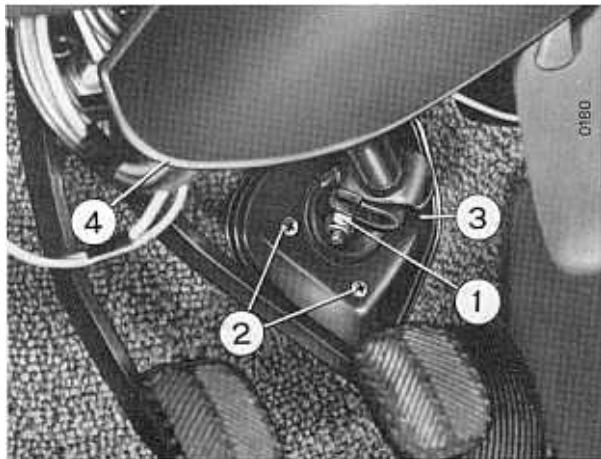

Fig. 12 2/8 - Connection between jointed steering column and rack housing worm

- From inside the vehicle, unscrew nut (1) and detach the jointed steering column from the rack housing worm.
- Unscrew the bolts holding the left panel of the centre compartment and remove the panel.
- Unscrew bolts (2) and take off the plate (3).

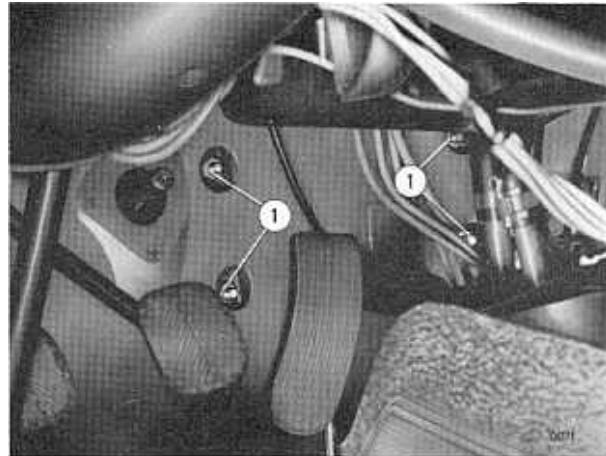

Fig. 12 2/9 - Attachment of rack housing

- Unscrew the nuts (1) holding the housing to the body and remove the body, complete with rods, from the left side of the vehicle.

Refitting

Note: before commencing, set the housing and the steering wheel in the straight-ahead position. To do this, count how many times the worm turns to move the rack from one lock to the other. Divide the number by two and position the worm accordingly.

- Refit in the reverse order. Tighten all bolts and nuts to the correct torque loading. Check and, if necessary, correct the toe-out as described at para. 12 2 0010.

TOOLS REQUIRED

- 88062036 - Tool for driving of ball joints
- 88091135 - Torque spanner
- 88097120 - Stands
- 8897829 - Crosspiece for lift

§ 12 2 3900

RENEWAL OF A (RIGHT OR LEFT) STEERING ROD BALL JOINT

Stand the vehicle over the pit, fit cover 88083051 and *proceed as follows:*

- Slacken the bolts on the wheel concerned



Fig. 12 2/10 - Position of lift

- Raise the vehicle with a pillar lift in the position shown in the figure. Set stands 88097120 beside the vehicle. Lower the vehicle onto the stands and take off the wheel.

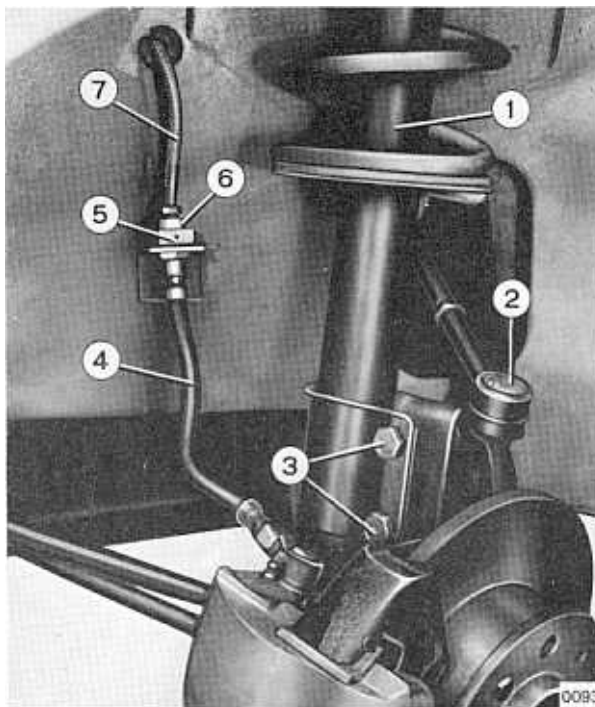

Fig. 12 2/11 - Steering rod ball joint pin

Loosen nut (8). Unscrew the nut holding the pin. Use tool 88062032 to drive off the ball joint and unscrew the pin. Note the position in which the pin is mounted with respect to the rod (e.g. by counting the number of turns the pin makes before it comes away from the rod).

Reassembly

- Screw the new pin on the rod to the same position as that occupied by the one removed. Remount the pin on the swivel and tighten its locking nut and nut (8) to the correct torque loading.
- On completion, check the toe-in as described at para. 12 2 0010.

TOOL REQUIRED

- 88062032 - Tool for driving off ball joints

§ 12 2 4000

REMOVAL AND REFITTING OF SWIVEL COMPLETE WITH FLANGE AND BEARING FOR FRONT WHEEL HUBS

Stand the vehicle over the pit, fit covers 88083051 and *proceed as follows*:

Removal

- Slacken the wheel on the side concerned

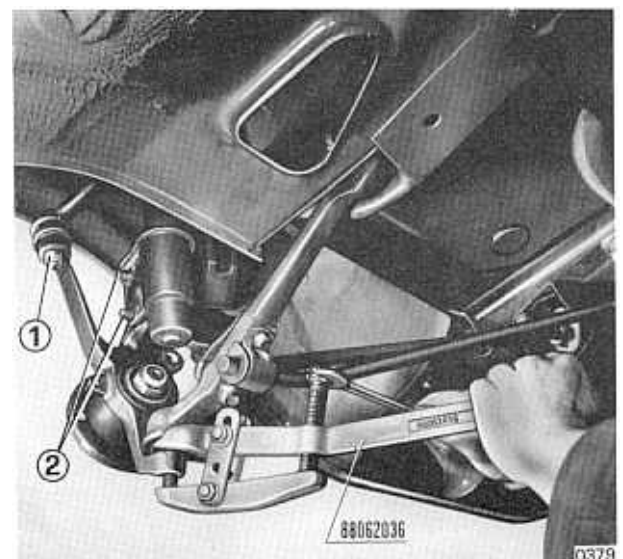

Fig. 12 2/12 - Tool for removing swivels

From the pit:

- Raise the vehicle, rest it on trestles and take off the wheel.
- Unscrew the two bolts holding the caliper.

Take off the caliper, complete with carrier, and fix it to one side; unscrew the two bolts holding the brake disc and remove the disc.

- Unscrew nut (1). Unscrew the nut holding the pin that joins the arm to the swivel.
- Use tool 88062036 (mounted as shown in the photo) to drive off the two ball joints. Unscrew bolts (2) and take off the swivel (1).

Refitting

- Refit in the reverse order. Tighten parts (1) &

(2), and the bolts holding the brake disc and the caliper, to the correct torque loadings.

TOOL REQUIRED

- 88062036 Tool for removing swivels

(1) Renewal of the flange and bearing are dealt with at para 08 4 0300.

CHAPTER 4

§ 12 4 0300

OVERHAUL OF RACK HOUSING

Proceed as follows:

Disassembly

- Disconnect the ball joint (1) from the rod (2).

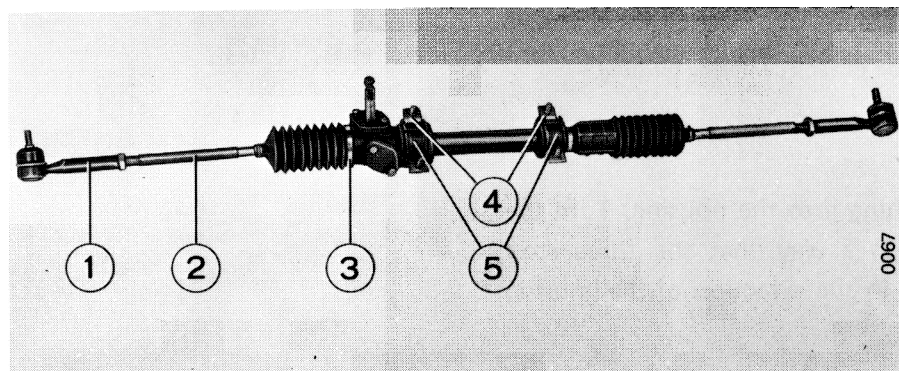

Fig. 12 4/1 - Rack housing assembly

- Mount the housing in a lead-jawed vice
- Uncrimp and unscrew the nut holding the rod to the rack.

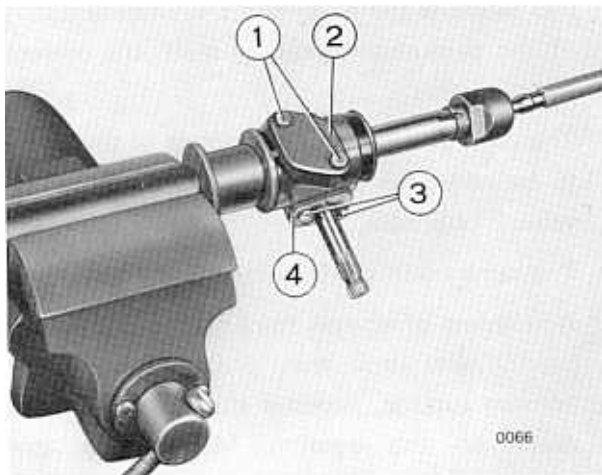

Fig. 12 4/2 - Rack housing

- Unscrew bolts (3), remove the worm cover (4), the shims, the worm and its bearing. Slide the rack and bushing out of the housing.
- Take off the bottom bearing.

Loosen the clamp (3). Take off the cap on the housing side and drain off the oil from the housing. Take off the other cap.

- Detach the clamp (4) and the packings (5).

Checks

- Wash all disassembled parts and blow dry with compressed air.
- Check the caps carefully for cuts and holes. Check that the rack locating piece is not over-tight in its seating on the housing, and is free from undue wear (particularly in cases where the housing has been working without oil).
- Check the worm teeth for signs of wear or chipping. Renew the worm if necessary.
- Check that the bearings are not worn and that the rack surface that touches the locating piece is free from wear or scratches.
- Check the rack teeth for signs of wear or chipping. Renew the rack if necessary.
- Renew the seal on the worm cover. The new seal must be fitted at the level of the cover with the aid of tool 8806031.

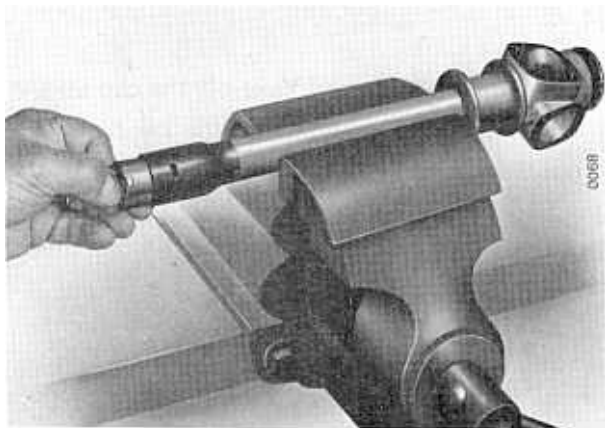

Fig. 12 4/3 - Insertion of rack centering bushing

Reassembly

Insert the bushing into the housing. Turn the bushing in such a way that the three stop projections lie in the direction of the housing seating.

Fit the bottom bearing on the housing. As shown in fig. 12 4/4 , insert the rack. Mount the worm with the shoulder upwards. Fit the top bearing and the shim of known thickness.

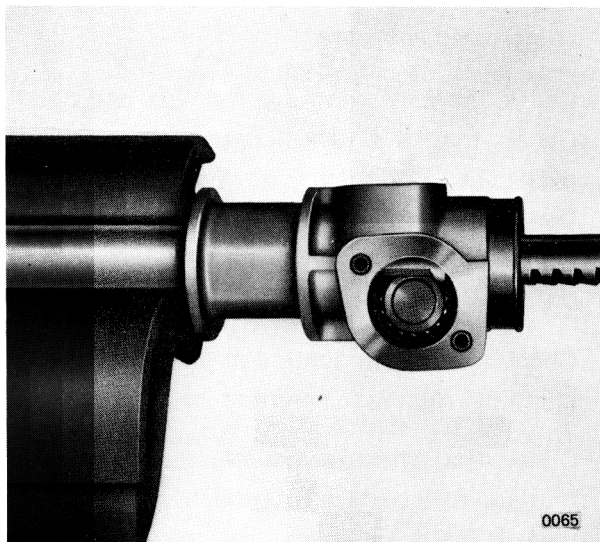

Fig. 12 4/4 - Position of the rack

- Check the preloading of the bearings. This is done by fitting tool 88065001 on the rack housing. Gauge 88095122 and depth gauge 88095851 are used in conjunction with a 120 mm stem.

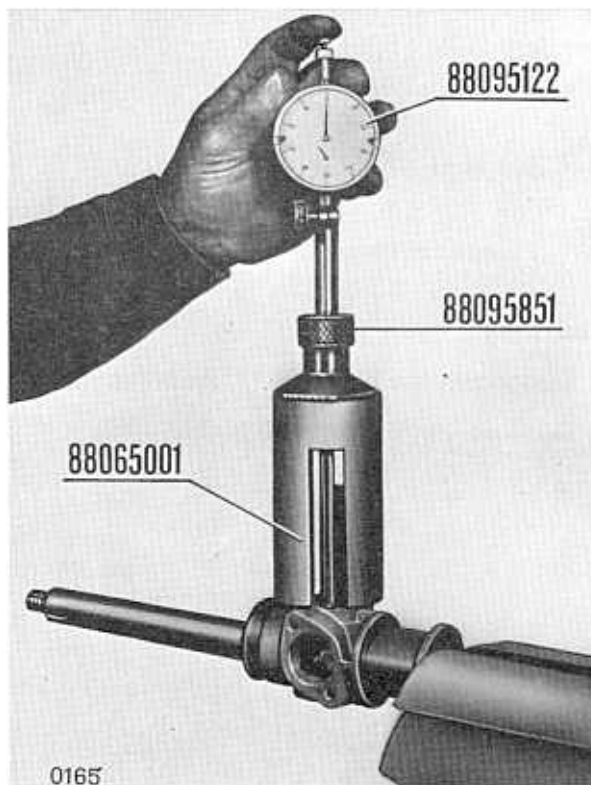

Fig. 12 4/5 - Checking the gap between the rack housing face and the top bearing to set the preloading of the bearings.

- Zero the dial gauge on the rack housing face and read off the cover seal thickness and that of the thickness needed to reach the correct preload value.
- The total will show the thickness of the shims to be added to the known shim so that this value is obtained.
- The same result can be achieved as follows:
- Add shims of known thickness to the pinion bearing seal until they project beyond the housing surface. Remove the seal and fit the cover on the housing. Measure the gap between the two points shown as G in fig. 12 4/6 . Work out the difference between this gap and the thickness of the shims. Add the thickness of the seal to the result, plus the prescribed preload value. This will give the thickness of the shims to be applied.

e. – thickness of shims mounted on the known shim – gap distance G + preload value = thickness of shims to be mounted.

- Take off the various shims and fit the bearing with shims to obtain the calculated value. Remount the known shim and the cover, complete with its seal. Tighten the bolts to the correct torque loading.
- Use tool 88069006 and torque meter 88095138 to ensure that the rolling torque value is correct.

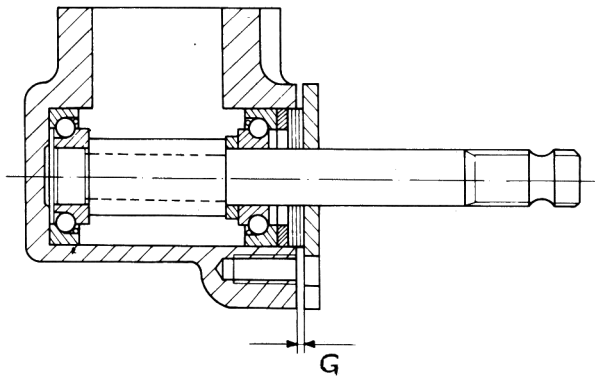

Fig. 12 4/6 - Measurement of bearing preload.

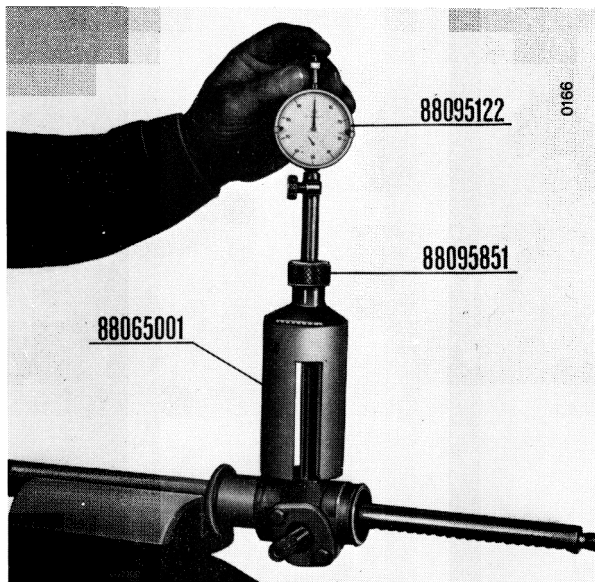

Fig. 12 4/7 - Checking the difference in height between the housing surface and the support to set the backlash between the worm and the rack.

- Set the rack about half-way into the housing and mount the locating piece in its seating.
- Use support 88065001 and a gauge to read off the difference in height between the housing surface and the top of the locating piece protruding from the housing. Add the value to the prescribed backlash value. This

will give the total thickness of the shims that must be fitted.

- The same result can be achieved as follows:

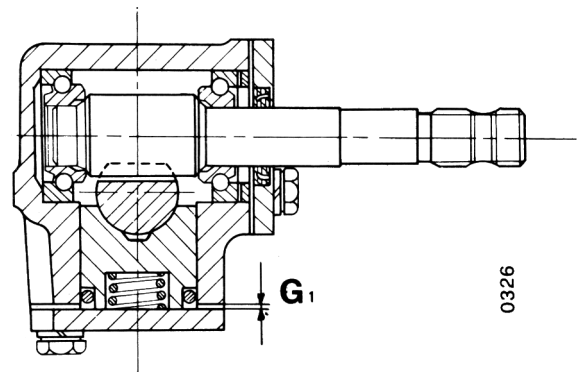

Fig. 12 4/8 - Measurement of rack locating preload.

- Use a feeler gauge to measure the gap between the bottom edge of the cover and the face of the housing (G). Add this value to the prescribed backlash value. This will give the total thickness of the shims that must be fitted.
- Mount the spring on the rack locating support, followed by the shims. Lastly, mount the cover and tighten the bolts to the correct torque loading.

Note: spread sealing compound over the mounting bolts and the edges of the shims to ensure that the rack housing is hermetically sealed.

- Fit the rods on the rack and tighten the nuts to the correct torque loading before crimping them.
- Mount the caps on the pins, taking care not to damage the clamps when sliding them on the threaded part.
- Fit one cap on the housing and clip it in place. Insert oil in the housing.
- Fit the second cap and clip it in place.
- Lastly, check that the rolling torque is correct with torque meter 88095138 and extension 88063006. Adjust if necessary by adding or removing worm bearing shims within the

limits of the prescribed minimum and maximum preloading values.

TOOLS REQUIRED

- 88062031 - Installer for rack housing cover seal.
- 88095138 - Torque meter

- 88063006 - Torque meter extension for measurement of rolling torque
- 88065001 - Tool used in checking rack housing clearances
- 88091134 - Torque spanner
- 88095122 - Dial gauge
- 88095851 - Depth gauge

BASIC MODEL

The directions and operations refer to the accessories fitted to all car models.

ACCESSORIES GROUP CONTENTS

CHAPTER 1

Troubles, probable causes, checkings and operations to be carried out

from page 13 1/1
to page 13 1/4

CHAPTER 2

§ 13 2 0200	Replacing one or both side or centre air vents	page 13 2/1
§ 13 2 0500	Removing and refitting the heater assy	" 13 2/1
§ 13 2 0900	Removing and refitting the heater cock	" 13 2/2
§ 13 2 1300	Replacing heater cock sheath and control lever	" 13 2/2
§ 13 2 2100	Removing and refitting the windscreen wipers assy	" 13 2/2
§ 13 2 2500	Renewal of wiper blades or levers	" 13 2/3
§ 13 2 2900	Removal and refitting the electronic clock	" 13 2/3
§ 13 2 3300	Removing and refitting the cigarette lighter	" 13 2/4
§ 13 2 3500	Removing and refitting the instruments cluster	" 13 2/4

CHAPTER 4

§ 13 4 0100	Overhauling the heater core	13 4/1
§ 13 4 0700	Removal and refitting of the instruments cluster	13 4/1

FAULT	PROBABLE CAUSES	CHECKS ADVISABLE BEFORE REPAIRING	ACTION NECESSARY	PARA
Heater fails to deliver warm air	Faulty heater tap and air blender sheath or cable	From inside the vehicle, check whether the tap at the side of the heater is being properly operated	Renewal of heater control levers and tap sheath or cable	13 2 1400
	Faulty heater tap	—	Renewal of heater tap	13 2 0900
	Faulty heater radiator	—	Removal and refitting of heater and heater radiator Overhaul of heater radiator	13 2 0500 13 4 0100
No air flows from centre vents	Closed or jammed vent flaps	—	Removal and refitting of heater assembly	13 2 0500
	Central vent flap closed	—	Renewal of centre vent	13 2 0200
No air flows from side vents	Side vents not properly seated	—	Removal and refitting of side vents	13 2 0200

FAULT	PROBABLE CAUSE	CHECKS ADVISABLE BEFORE REPAIRING	ACTION NECESSARY	PARA
Heater booster does not start	Booster switch not receiving current	Check fuses	Renew the fuse	—
	Faulty booster switch	—	Removal and refitting of the heater booster switch	14 2 3900
	Faulty booster motor	—	Removal and refitting of the booster motor	14 2 3100
Windscreen wipers ineffective	Worn wiper blades	—	Renewal of wiper blades or arms	13 2 2500
	Fatigued blade holder springs	—	Renewal of wiper blades or arms	13 2 2500
Windscreen wiper motor does not start	Wiper motor control not receiving current	Check fuses	Renew the fuse	—
	Wiper motor control faulty	—	Removal and refitting of wiper motor control	14 2 4610
	Faulty wiper motor	—	Removal and refitting of wiper motor	14 2 2800

FAULT	PROBABLE CAUSES	CHECKS ADVISABLE BEFORE REPAIRING	ACTION NECESSARY	PARA
Noisy windscreen wipers	Insufficiently lubricated blade holder arm shafts	—	Lubricate the shafts	
	Worn blades	Check whether noise occurs when the blades change direction	Renewal of wiper blades	13 2 2500
Washers do not operate	Clogged nozzles	Disconnect the plastic delivery hose from the washer motor and see whether liquid comes out when the control is operated	Use a steel needle to clean the nozzles	
Washers do not operate	Faulty washer motor control	—	Removal and refitting of wiper and washer motor control	14 2 4610
	Washer motor faulty	—	Renewal of washer motor	14 2 2900
Washer jet incorrectly aimed	Nozzles out of alignment or partly clogged	—	Clear or re-aim with a steel needle	—

FAULT	PROBABLE CAUSE	CHECKS ADVISABLE BEFORE REPAIRING	ACTION NECESSARY	PARA
Clock does not work	Clock not receiving current	Check fuses	Renew the fuse	—
	Faulty clock	—	Removal and refitting of instrument cluster Disassembly and reassembly of instrument cluster	13 2 3500 13 4 0700
Faulty speedometer	Worn drive on gearbox	—	Renewal of drive	
	Broken or worn ends of drive cable	—	Renewal of speedometer cable and sheath	—
	Faulty instrument	—	Removal and refitting of instrument cluster Disassembly and reassembly of instrument cluster	13 2 3500 13 4 0700
Speedometer needle flutters or over- or under- reads	Faulty instrument	—	Removal and refitting of instrument cluster Disassembly and reassembly of instrument cluster	13 2 3500 13 4 0700
Rev counter does not work, or needle flutters or over- or under-reads	Faulty instrument	—	Removal and refitting of instrument cluster Disassembly and reassembly of instrument cluster	13 2 3500 13 4 0700

CHAPTER 2

§ 13 2 0200

REPLACING ONE OR BOTH SIDE OR CENTRE AIR VENTS

Removing

- Insert the point of a screwdriver in the vent louvers and lower the upper retaining tabs (1) and (2), at the same time pulling the vent outwards so that it comes out of its casing. If there is any difficulty in extracting it, push the lower tabs (3) and (4) upwards and pull the vent away from its casing simultaneously.

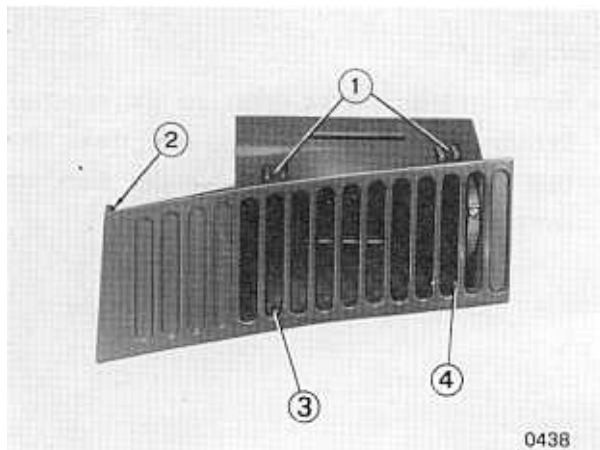

Fig. 13 2/1 - Side air vent

Refitting

- Fit the vent into its dashboard housing and press until the retaining tabs snap into place.

§ 13 2 0500

REMOVAL-REFITTING COMPLETE RADIATOR UNIT

Drive the car over the pit and *proceed as follows*:

Removal

- Detach the positive lead from the battery,

place a container below the vehicle and drain the water from the cooling circuit.

- Remove the gear control lever and the tunnel lining, undo the screws securing the left-hand panel of the cabinet and remove the panel.
- Open the glove compartment cover and remove the air control knob; then undo the screws holding the glove compartment and withdraw it.
- Disconnect the compartment light snap fitting and remove the screw and nut securing the the compartment light earth cable.
- Unscrew the screws holding the central cabinet to the tunnel and the instrument panel, and extract the heating control levers and the screws holding the heating control support.
- Disconnect the ash-tray light snap fitting, disconnect the cigarette-lighter cables and those of the clock, and remove the lamp.

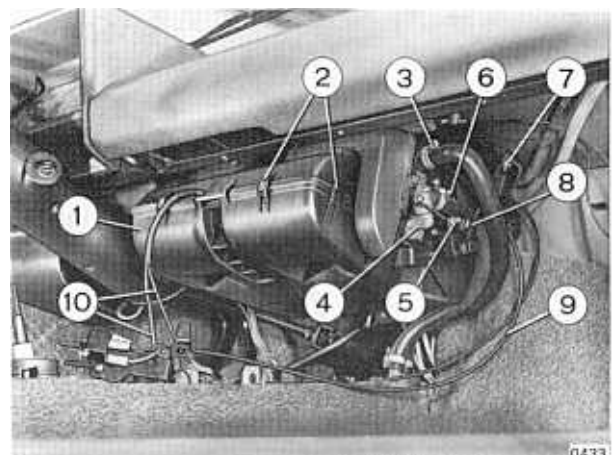

Fig. 13 2/2 - Heater

- Remove the heater and air outlet tap control sheath from the support bracket on the tunnel, remove clamp (3) and clamp (5), and then pull away the two pipes.
- Remove the electric leads (10) and unscrew nuts (7) holding the heater (1) to the body, and extract it.

Refitting

Refit in the reverse order. When the operation is completed, start the engine and deaerate the circuit. Also check that the connections do not leak and that controls are working properly.

§ 13 2 0900

REMOVING AND REFITTING THE HEATER COCK

Drive the car over the pit and *proceed as follows*:

Removing

- Go down into the pit, place a clean container under the drain plug and drain off the coolant; remove the battery and the glove locker complete with light.

For refs. see fig. 13 2/2

- Remove the heater cock flap link (), loosen the clip and disconnect the water inlet hose from the cock, remove the two bolts holding the cock to the heater and take it off along with the seal.

Refitting

- Fit the seal followed by all the parts removed earlier; before refitting the glove locker make sure the cock is working perfectly.

When the operation is complete, deaerate the cooling circuit as indicated at 01 2 4650.

§ 13 2 1300

REPLACING HEATER COCK SHEATH AND CONTROL LEVER

Proceed as follows:

Removing

Take out the battery, remove the air inlet control knob from inside the locker, remove the glove locker complete with light, remove the earth cable; unscrew the left side fixing screws of the console.

Remove the cock control sheath securing clip and casing union, pull off the control lever rod.

- Remove the self-threading screw holding the control sheath () plate () on the support (), then remove the heater cock control cable from the lever ().
- Check the parts and replace anything that is damaged.

Refitting

Refit in the reverse order to the removal; before refitting the left hand side, make sure that the cock and the blender flap are working perfectly.

§ 13 2 2100

REMOVAL AND REFITTING OF A WIND-SCREEN WIPER ASSEMBLY

Fit covers 88083051 and 88083056 and *proceed as follows*:

- Remove the positive battery lead to disconnect the electrical equipment. Unscrew bolts (1), take out plug (2), undo nut (3) and screws (4) and slide out the wiper motor (5).
- Unscrew nuts (6), take off lever (9), unscrew nuts (8) and take off components (9). Unscrew bolts (10). Disconnect the detergent delivery hose from the sprinkler (11) and remove the wiper levers.

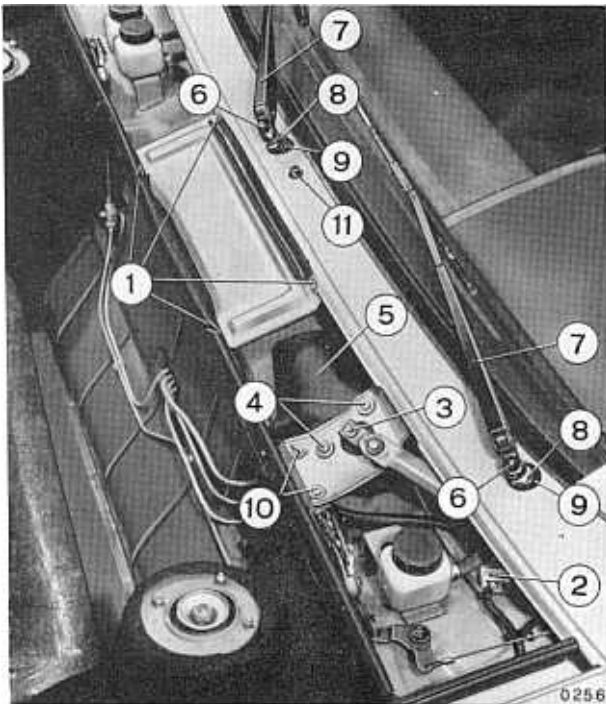

Fig. 13 2/3 - Windscreen wiper assembly

At the bench:

- Take off the mounting springs and remove the levers. Check the effective operation of the link rod joints. Renew the lever assembly in the case of wear between the bushings and pins.

Refitting

- Refit in the reverse order. Lubricate the pins and link rod joints.

Note: on reassembly, the levers should be in the position shown in fig. 13 2/3 when the motor is off.

- Check that the wipers are working properly.

§ 13 2 2500

RENEWAL OF WIPER BLADES OR LEVERS
(see fig. 13 2/4)

Fit covers 88083051 and *proceed as follows:*

Removal

For refs. see fig. 13 2/3

- Operate the lever check springs so as to be able to remove the wiper blades. If necessary, unscrew nuts (6) and take the levers (7) from their drive shafts. Renew all worn parts.

Refitting

- Refit in the reverse order.

Note: levers (7) with their blades must be mounted with the motor in the automatic parking position and locked with pins in such a way that they do not touch the windscreen upright when the wipers are moving.

§ 13 2 2900

**REMOVAL AND REFITTING OF THE
ELECTRIC CLOCK**

Fit covers 88083056 and *proceed as follows:*

Removal

- Remove the positive battery lead to disconnect the electrical equipment. Undo the three screws holding the left dashboard side section (1), extract the electric clock from its seat, and disconnect the leads and lampholder.

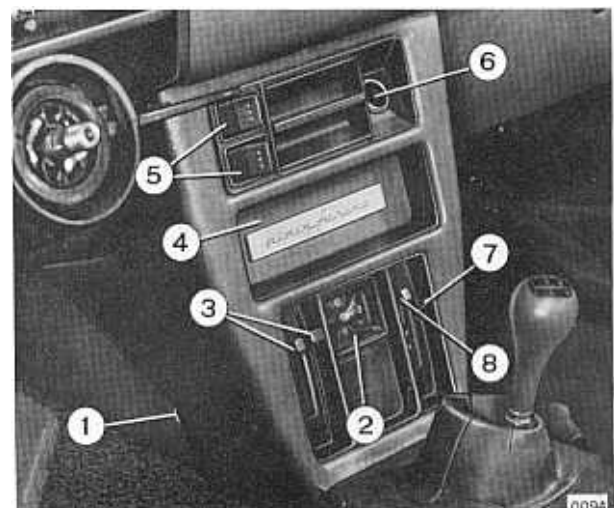

Fig. 13 2/4 - Centre cluster

- Refit in the reverse order.

§ 13 2 3300

**REMOVAL AND REFITTING OF THE
CIGARETTE LIGHTER**

Fit cover 88083056 and *proceed as follows*:

Removal

Remove the positive battery lead to disconnect the electrical equipment. Take off the left dashboard side section, disconnect the lighter leads from their snap fittings, unscrew the ring nut holding the lighter and withdraw the latter.

Refitting

– Refit in the reverse order and check that the lighter works properly.

§ 13 2 3500

**REMOVAL AND REFITTING OF THE
INSTRUMENT CLUSTER** (speedometer, rev
counter, fuel gauge, oil pressure gauge, radiator
temperature telltale)

Fit covers 88083056 and *proceed as follows*:

Removal

Remove the positive battery lead to disconnect the electrical equipment. Unscrew screws (1).



Fig. 13 2/5 - Instrument cluster

– Take off the fuse cover (2) and speedometer sheath.

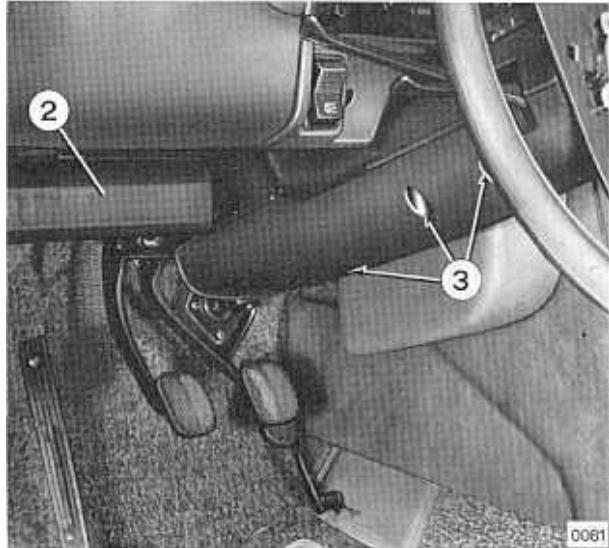

Fig. 13 2/6 Fuse cover and steering column half-casings.

Partly withdraw the cluster and disconnect the terminals.

Remove the cluster (10).

At the bench

– Slide off the side paddings (4), unscrew screws (5) and slide the instruments from their support.

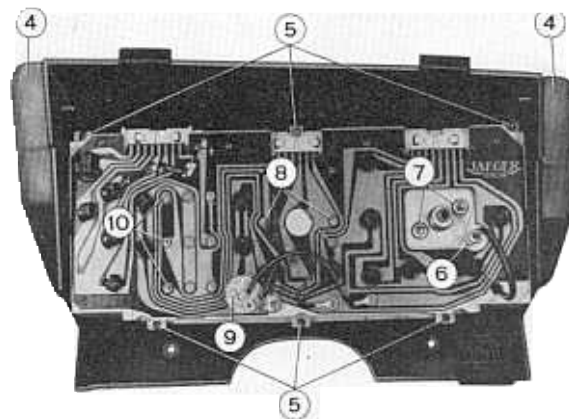

Fig. 13 2/7 - Rear view of instruments cluster

– Refit in the reverse order and check that the instruments work properly.

(*) Disassembly and reassembly of the cluster is described at para. 13 4 0700.

CHAPTER 4

§ 13 4 0100

OVERHAULING THE HEATER CORE

Proceed as follows:

- Plug one of the two core ports and fit the air pressure hose to the other port; introduce air into the core, making sure not to exceed a pressure of 0.6 atm.
- Dip the core in a tank full of water and locate the leaks. Then clean the leaking part or parts with a wire brush and acid (zinc chloride) and a liquefied gas torch, then soft solder.
- If the test shows that the leak is due to poor sealing between the tubes and tanks and which therefore cannot be repaired from the outside of the core, proceed as follows:
 - Unsolder the two tank covers and remove any tin residues with a wire brush.
 - Clean the tube and plates with acid and a wire brush and soft solder again so that the tinned surface is evenly spread.
 - Refit the tanks and soft solder them. Repeat the test. Then clean the outside of the core with water and compressed air, straighten any bent gill and spray the core with black synthetic enamel.

§ 13 4 0700

REMOVAL AND REFITTING OF INSTRUMENTS CLUSTER

When one or more of the instruments in the cluster have to be renewed, *proceed as follows:*

- Slide off the light control knob, the ring holding the trip recorder sheath, remove the ornamental section, screws (7) and nuts (8) holding the speedometer and rev counter respectively. Take out the bayonet-mounted lamp.

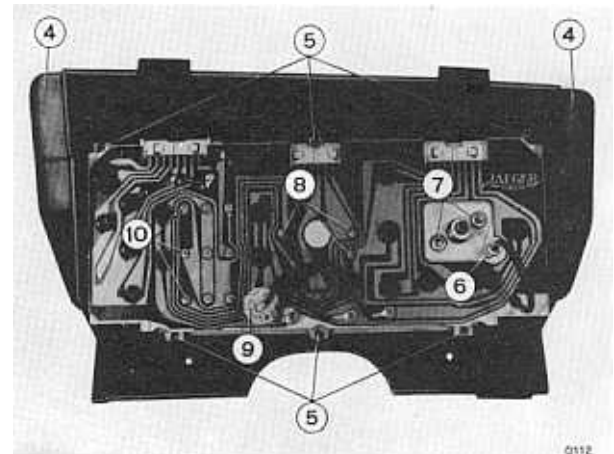

Fig. 13 4/1 - Instruments cluster

- Refit in the reverse order.

BASIC MODEL

The directions and operations refer to the electric system fitted to all car models.

VARIANTS

– Variant **SCORPION**

The directions and operations refer to the electric system fitted to the SCORPION versions only 137 AS 6.

ELECTRIC SYSTEM GROUP CONTENTS

CHAPTER 1

Troubles, probable causes, checkings and operations to be carried out

from page 14 1/1
to page 14 1/5

CHAPTER 2

§ 14 2 0100	Checking the alignment and aiming the headlamps using optical equipment	page 14 2/1	
§ 14 2 0400	Checking the battery charge and cleaning the terminals	" 14 2/2	
§ 14 2 1000	Removing and refitting a right, or left front beam unit, including renewal of the bulb	14 2/2	
	Do for SCORPION cars	14 2/1	Variant SCORPION
§ 14 2 2800	Removing and refitting the windscreen motor	14 2/2	
§ 14 2 3100	Removing and refitting the heating and ventilation booster motor	14 2/3	
§ 14 2 4610	Removing and refitting the windscreen wipers, turn indicators and headlamps controls	14 2/3	
§ 14 2 6000	Removing and refitting the fuse holder	14 2/12	
§ 14 2 6800	Removing and refitting headlight fitter motor	14 2/1	Variant SCORPION
§ 14 2 6900	Removing and refitting the fuse holder	14 2/4	
§ 14 2 7200	Removing and refitting the alternator	14 2/4	
§ 14 2 7500	Removing and refitting the voltage regulator	14 2/5	

CHAPTER 4

§ 14 4 0420	Overhauling the starter motor	page 4 4/1
§ 14 4 0520	Renewing the starter motor field coil	" 4 4/4
§ 14 4 0800	Overhaul of the alternator	" 4 4/4
§ 14 4 0900	Recharging the battery	" 4 4/6

FAULT	PROBABLE CAUSES	CHECKS ADVISABLE BEFORE REPAIRING	ACTION NECESSARY	PARA
Starter motor turns slowly or not at all	Flat battery Oxidised terminals	—	Check battery charge and clean terminals	14 2 0400
	Loose starter motor connections	—	Tighten the connections	—
	Inefficient starter motor	—	Remove and refit motor Bench test motor Overhaul motor	14 2 6900 16 4 6400 14 4 0420
	Ignition switch faulty	—	Remove and refit ignition switch	
Alternator telltale stays on	Faulty alternator	—	Remove and refit alternator Bench test alternator Overhaul alternator	14 2 7200 — 14 4 0800
	Voltage regulator faulty	—	Remove and refit voltage regulator	—

FAULT	PROBABLE CAUSES	CHECKS ADVISABLE BEFORE REPAIRING	ACTION NECESSARY	PARA
Alternator telltale stays off when key turned and engine off	Blown bulb	—	Remove and refit instrument cluster	13 2 3500
	Faulty brushes	—	Renew alternator brushes	—
	Faulty voltage regulator	—	Remove and refit voltage regulator	—
Alternator telltale stays off when key turned and engine off	Slack alternator drive belt	—	Tighten belt	—
	One or more diodes faulty	Listen ofr unusual humming	Remove and refit alternator Bench test alternator Overhaul alternator	14 2 7200 — 14 4 0800
	Voltage regulator faulty	—	Remove and refit voltage changer	—
Noisy alternator	Worn alternator bearings	—	Remove and refit alternator Overhaul alternator	14 2 7200 14 4 0800

FAULT	PROBABLE CAUSES	CHECKS ADVISABLE BEFORE REPAIRING	ACTION NECESSARY	PARA
Uneven headlamp brightness	Wrongly directed headlamp	—	Check alignment of headlamps	14 2 0100
	Rusty reflectors	—	Remove and refit headlamp beam units	—
Faulty headlamp dip switch	Faulty traffic beam solenoid switch	—	Remove and refit traffic beam solenoid switch	—
	Dip switch faulty	—	Remove and refit turn indicator and headlamp controls	14 2 4610
Backing lights do not come on	Blown bulbs	—	Renew bulbs	—
	Backing lights switch faulty	Short-circuit switch leads and see whether lights come on	Remove and refit backing light switch	—
Backing lights stay on	Backing lights switch faulty	—	Remove and refit backing lights switch	—

FAULT	PROBABLE CAUSES	CHECKS ADVISABLE BEFORE REPAIRING	ACTION NECESSARY	PARA
Turn indicators do not work	Faulty indicators control	—	Remove and refit indicators control	14 2 4610
	Faulty flasher switch	—	Renew flasher switch	—
Turn indicators change and cancel control does not work	Faulty indicators control	—	Remove and refit turn indicator and headlamp control	14 2 4610
Windscreen wipers do not work	Faulty control switch	—	Remove and refit windscreen wipers and sprayer control	14 2 4610
	Wipers motor faulty	—	Remove and refit windscreen wipers motor	14 2 2800
Horns do not work	Horn control defective	—	Remove and refit horns control	—
	Horns solenoid switch faulty	—	Remove and refit horns solenoid switch	—
	Horns faulty	—	Remove and refit the horns	—
Rear window defroster does not work	Rear window solenoid switch faulty	—	Remove and refit rear window solenoid switch	—
	Rear window defroster control switch faulty	—	Remove and refit rear window defroster switch	—

FAULT	PROBABLE CAUSES	CHECKS ADVISABLE BEFORE REPAIRING	ACTION NECESSARY	PARA
Rear window defroster does not work	Loose rear window electrical connections	—	Tighten connections	—
Instruments lights do not work	Faulty instruments lights adjustment switch	—	Remove and refit instruments lights switch	—
Heater fan does not work	Faulty fan motor	—	Remove and refit heater fan motor	14 2 3100
Electrical cooling fan does not work	Faulty cooling fan solenoid switch	Check that the fuse on the power cable has not blown. See whether the fan works when connected straight to the battery	Remove and refit the cooling fan solenoid switch	—

CHAPTER 2

§ 14 2 0100

CHECKING ALIGNMENT AND AIMING HEADLAMPS USING OPTICAL EQUIPMENT

Proceed as follows:

- Set the unladen car on a perfectly flat floor, check tyre pressure and make sure that the suspensions are in good condition.

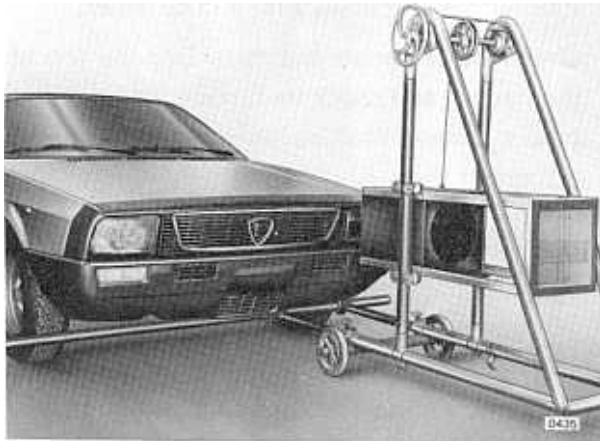

Fig. 14 2/1 - Checking headlamp alignment with equipment 88075020

- Set the front wheels in straight ahead position and place equipment 88075020 in front of one low beam headlamp. The centre of the equipment lens should be in line with the centre of the headlamp and about 300 mm from it. The lower cross bar should be touching both front wheels.
- Turn the low beams on and check that the horizontal edge of the bright spot is parallel with the horizontal lines on the screen and the slanted edge is parallel with the sloping lines.

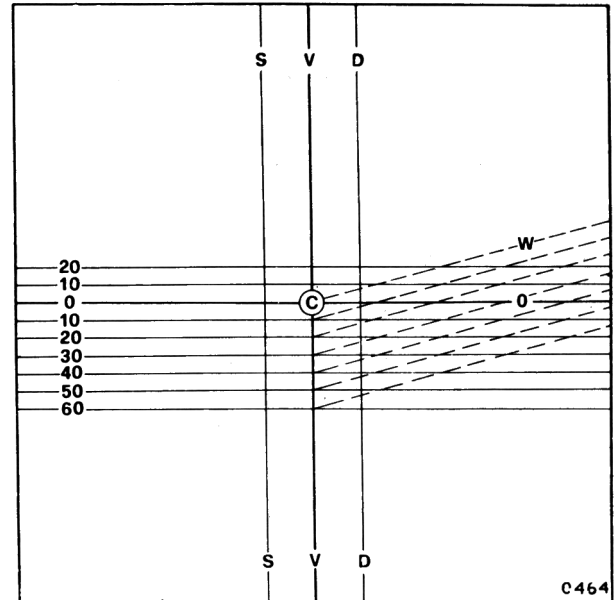

Fig. 14 2/2 Datum lines on screen of equipment 88075020

- The intersection of the horizontal and slanted edges of the bright spot should coincide with the V-V vertical on the screen, or otherwise lie between verticals V-V and S-S (left-hand low beam headlamp).

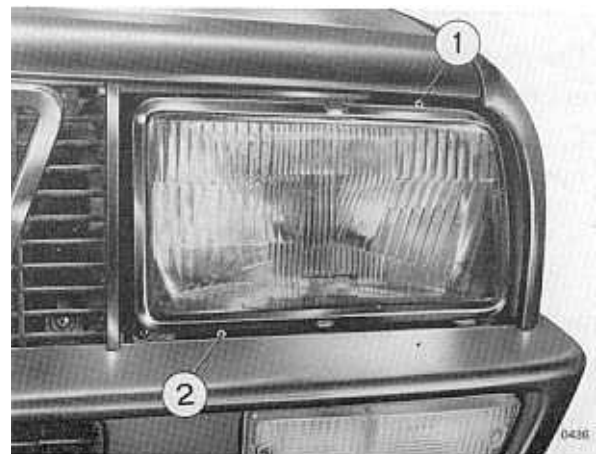

Fig. 14 2/3 - Headlamp aiming screws

- If this does not occur, adjust screw (1) as necessary.
- For vertical alignment, check that the horizontal edge of the bright spot registers with line No. 10 below line O-C-O on the screen. If it does not, adjust the screw (2) as

necessary.

Note: For headlamp aiming procedures it is sufficient to check the low-beam spot because the lighting clusters on this model serve for both high and low beams.

- Repeat the foregoing operation for the right-hand headlamp, bearing in mind that horizontally, the intersection between horizontal and sloping edges should align with the vertical line V-V or lie between the lines V-V and D-D.

TOOLS REQUIRED

88075020 Headlamp aiming equipment.

§ 14 2 0400

CHECKING THE BATTERY CHARGE AND CLEANING THE TERMINALS

Fit covers 88083051 and *proceed as follows:*

Check the electrolyte level and top up with distilled water if necessary. Wait till this mixes in thoroughly with the acid solution.

Use thermometer 88075002 to check that the electrolyte temperature is between 15 and 20° C. Check the density of each cell with hydrometer 88075001.

Note: readings must be taken with the instrument in the vertical position. The float should be half-way up the glass. The density value is shown by the point where the float breaks the surface.

- Return the electrolyte to the cell after taking each reading.
- To check the charge condition of the battery, compare the density readings with the values given in the table.

Battery charge-%	Density of electrolyte
100	1.28
75	1.25
50	1.22
25	1.19
poor	1.16
flat	1.11

Next, take off the battery terminals and their nuts. If oxidation makes this difficult, moisten the terminals with a little water.

Clean the terminals and nuts. Dry the top of the battery and check its surface for bumps or cracks. Smear vaseline on the terminals and reconnect them.

§ 14 2 1000 *Variant*

REMOVAL AND REFITTING A RIGHT OR LEFT FRONT BEAM UNIT, INCLUDING RENEWAL OF THE BULB

- Fit covers 88083051 and *proceed as follows:*
- From the luggage compartment, unscrew the nuts holding the unit to the body from above. From outside the vehicle, unscrew the two bolts that hold it from below.
- Take out the unit, turning it as necessary.
- Detach the unit from its support.
- Undo the snap fitting, slip off the guards and renew the bulb.
- Refit in the reverse order.

§ 14 2 2800

REMOVING AND REFITTING THE WINDSCREEN WIPER MOTOR

Fit the covers 88083051 and 88083056 and *proceed as follows:*

Removing

- Remove the positive cable from the battery, take out the multiple plug (3), unfasten the nut holding lever (1) and bolts (2) and take out the motor.

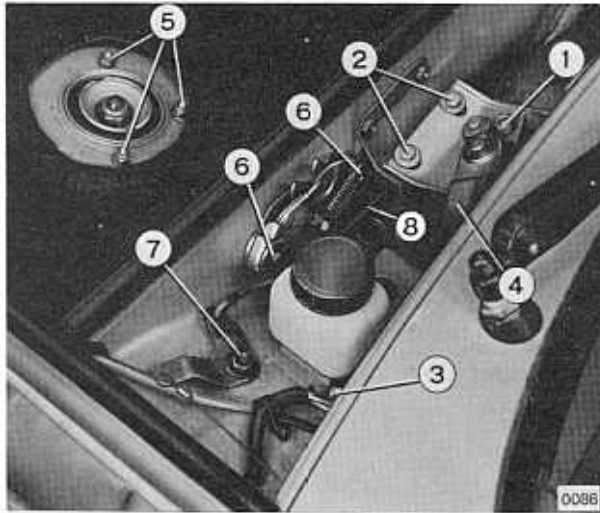

Fig. 14 2/4 - Windscreen wiper control motor and lever

Refitting

- Refit in the reverse order; when this has been done, check that levers 1 and 4 are arranged as in the figure and that the motor is working correctly.

§ 14 2 3100

REMOVING AND REFITTING THE HEATING AND VENTILATION BOOSTER MOTOR

Proceed as follows:

- Lift off the centre console as described at 13 2 0500.

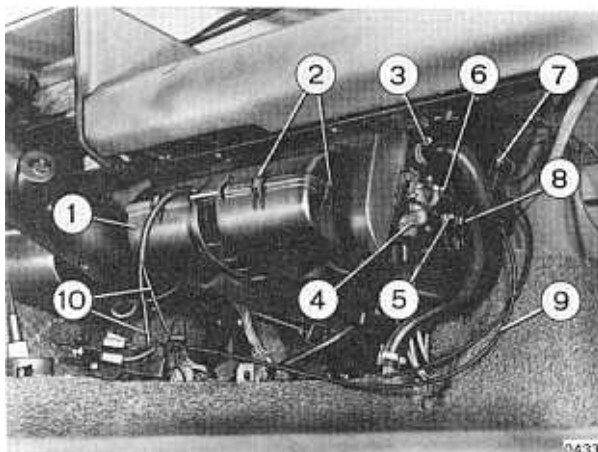

Fig. 2/5 - Removing heater motor

- Slip off the retainers (2) and remove the lower part (1) of the heater and detach the heater motor from it.
- Refit in the reverse order, ending up by refitting the centre console as described at 13 2 0500.

§ 14 2 4610

REMOVING AND REFITTING THE WINDSCREEN WIPERS, TURN INDICATORS AND HEADLAMPS CONTROL

Proceed as follows.

- Remove the steering wheel as described at 12 2 1000.
- Unfasten the securing bolts and remove the steering column casings.
- Detach the control cables and then loosen the screw securing the windscreen wiper, turn indicators and headlamps control and remove it.
- Refit parts in the reverse order; when the operation is completed, check that the system is working correctly.

§ 14 2 6000

REMOVING AND REFITTING THE FUSE HOLDER

Proceed as follows:

Removing

- Disconnect the positive cable from the battery.
- Disconnect the guard below the panel, unfasten the securing screws and remove the fuse-holder.
- Disconnect the fuse-holder cables, checking that they correspond to the wiring diagram and if necessary marking their position.

Refitting

- Connect the cables to the fuse-holder and the

latter to the body.

Refit the guard and, after reconnecting the positive lead, check that all controls are working normally.

§ 14 2 6900

REMOVING AND REFITTING THE STARTER MOTOR

Drive the car over the pit, fit the covers 88083051 and *proceed as follows*:

Working above the car:

- Detach the positive battery lead.
- Take out the spare wheel.
- Remove the bolts securing the starting motor to the gearbox.

Working below the car:

- Remove the air shroud.

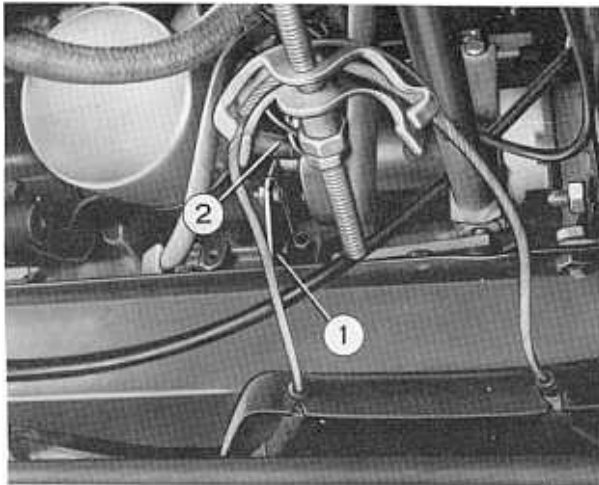

Fig. 14 2/6 - Removing starter motor

- Unfasten the bolts holding the starter motor support bracket (1) to the crankcase.
- Detach the motor feed cable and the armature excitation cable.
- Detach cable (2) and then remove the thermistor.
- Remove the starter motor.
- Refit in the reverse order.

§ 14 2 7200

REMOVING-REFITTING ALTERNATOR

Drive the car over the pit and fit protections 88083051; *proceed as follows*:

Working above the car

- Remove the positive battery lead.
- Remove the various electric connections from the alternator; undo the bolt securing the alternator from the top.

Working below the car

Remove the lower air shroud

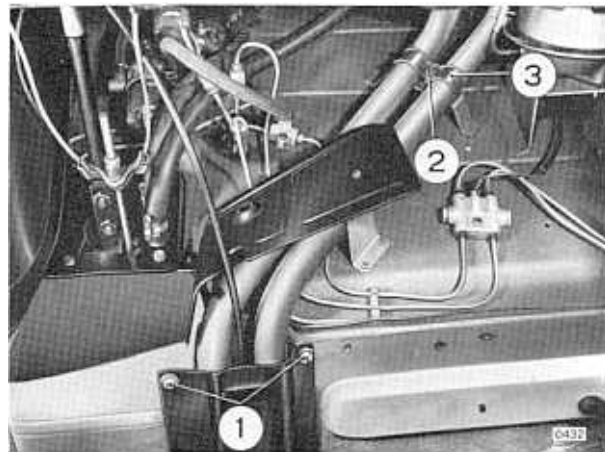

Fig. 14 2/7 Coolant pipes

- Remove bolts (1), undo nut (2) and remove plate (3).

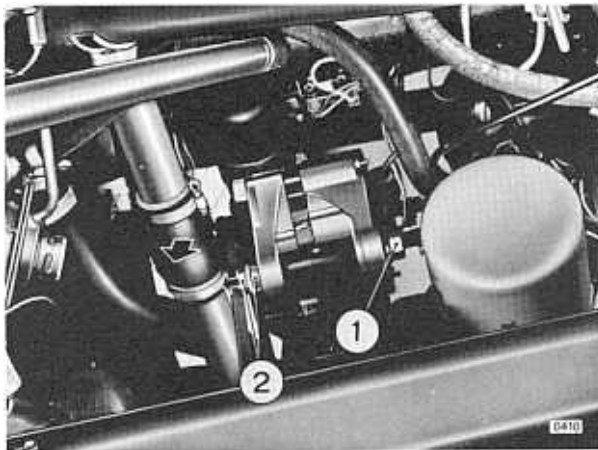

Fig. 14 2/8 Removing alternator

- Remove nut (1), lower the coolant pipe in the direction of the arrow and remove the bolt (2)
- Remove the alternator after freeing it from the drive belt.
- Refit in the reverse order to the removal.

- Tighten the belt as indicated in the relative technical data, then tighten the alternator clamping nut to the specified torque loading.

§ 14 2 7500

REMOVAL AND REFITTING THE VOLTAGE
REGULATOR

Fit covers 88083051 and *proceed as follows:*

- Detach the positive battery lead.
- Take off the regulator snap fittings and make a note of the colours of the leads.
- Unscrew the nuts holding the regulator and remove it from the body.
- Refit in the reverse order.

CHAPTER 4

§ 14 4 0420

OVERHAULING THE STARTER MOTOR

After bench testing as described at para 16 4 6400, *proceed as follows:*

Disassembly

- Clean the outside of the starter motor with petrol and blow dry with compressed air.

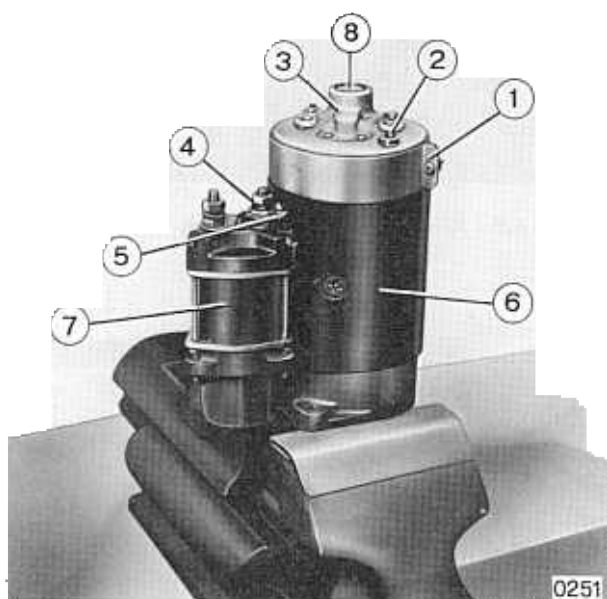

Fig. 14 4/1 - Disassembly of starter motor

- Clamp the motor in a lead-jawed vice and take off the collar (1).
- Unscrew nuts (2), remove the brushes and take off their holder (3).
- Slacken nut (4), free the lead (5) and take off the electromagnet (7).

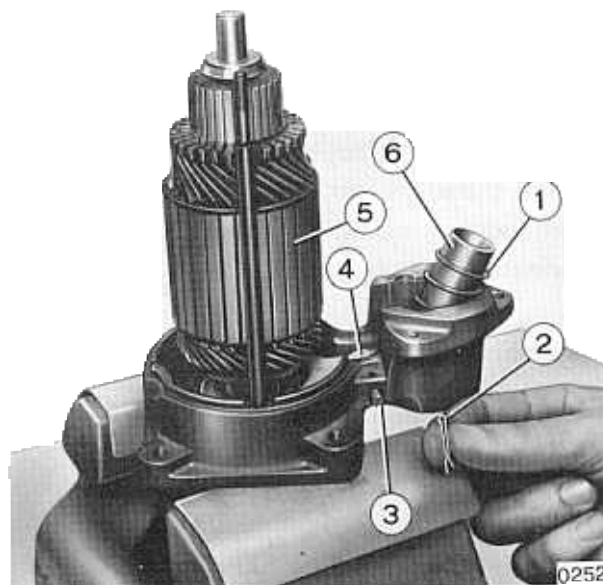

Fig. 14 4/2 - Disassembly of armature

- Remove spring (1) and cotter pin (2). Detach pin (3) from the fork (4) and then take off the armature, complete with the fork (4) and the core (6).
- Separate the fork (4) and core (6) from the armature (5).

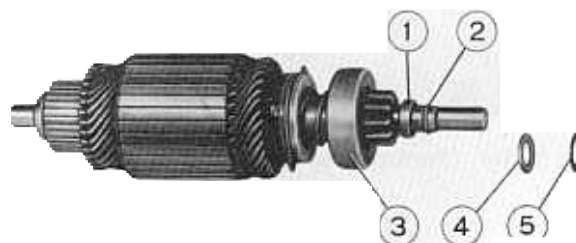

Fig. 14 4/3 - Disassembly of pinion.

- Use tool 88012350 to drive ring (1) down. Extract the circlip (2) and slide it off together with ring (1) and the pinion (3).
- Decrimp the cap (8) (see fig. 14 4/1). Use driving tool 88072008 and a press to drive the

bushing from the brush-holder and the bottom support (4).

Checking and overhaul

- Thoroughly clean all disassembled parts and blow dry with compressed air.
- Examine for wear and renew as necessary.
- Check that the free-wheel works properly and that there are no signs of burning in the armature winding. If there are, the entire armature must be changed.

Checking the armature for faulty insulation, broken connections and short-circuits

Insulation check



Fig. 14 4/4 - Checking armature insulation

- Place the armature on the insulated portion of test stand 88075016. Insert the probe leads in the "insulation test" sockets and set the switch (1) to "Mains".
- Use the probes to check the insulation of the commutator and winding with respect to the segments and shaft.

If the insulation is faulty, telltale (3) will come on.

Continuity check

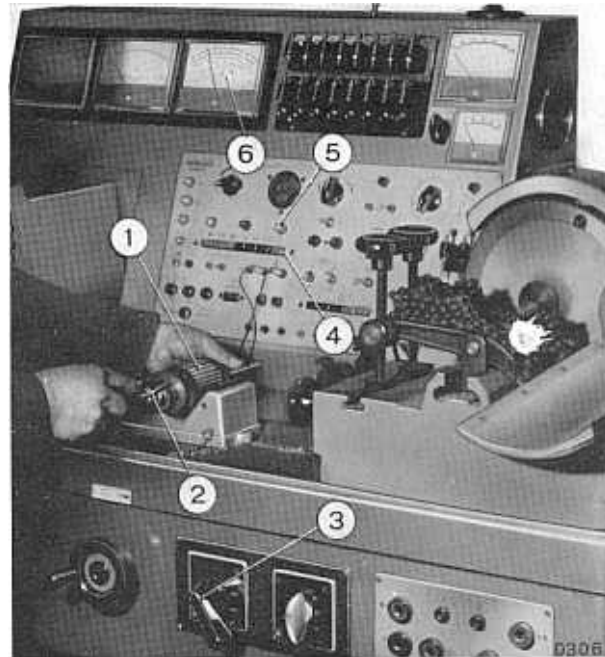

Fig. 14 4/5 - Armature continuity check

- Turn switch (3) to the "Mains" position and place the armature (1) on the testing pole shoes. Turn the tester on by means of its switch. Lamp (5) will come on.
- Connect the bench twin-contact clamp to the instrument sockets.
- Rest the clamp contacts on two adjacent segments and turn the armature slowly. The ammeter (6) should show a reading of some kind when this test is carried out on all the pairs of segments.
- If no reading is obtained at any point, there is a break in the armature windings. The armature itself must therefore be changed.

Short-circuit check



Fig. 14 4/6 - Armature short-circuit check

- Set switch (1) to "Mains". Place the armature (4) on the testing pole shoes (2). Turn the tester on by means of button (5). Rest blade (3) on the armature segments and turn the armature slowly.
- Short-circuits will be shown by vibrations of the blade at the recesses where fault windings are located. The armature itself must therefore be changed.
- Check the commutator for ridges, signs of burning or excessive ovalisation. If necessary, bring it back to a cylindrical shape on a lathe, and then check it for eccentricity as follows:
- Place the armature on parallel blocks 88095602 and fit gauge 99095122 on base 88095768. Rest the gauge probe on the commutator. Turn the armature and check that the commutator is not more than 0.01 mm out of true.

Checking the field coil windings for broken connections and faulty insulation

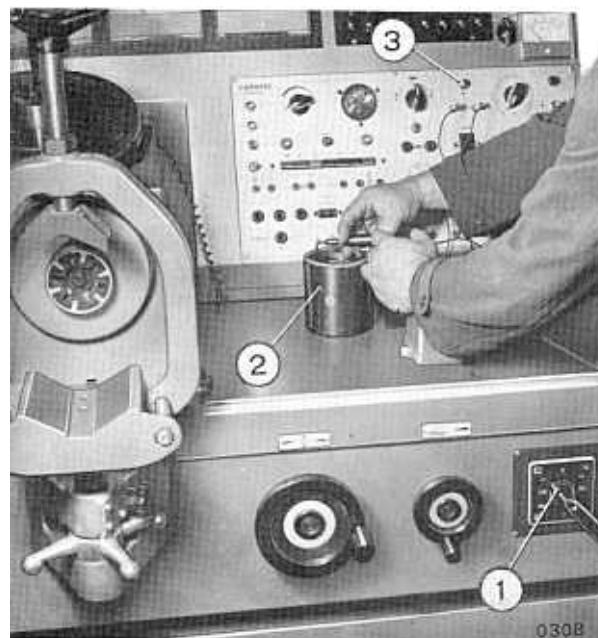

Fig. 14 4/7 - Field coil continuity check

- Turn switch (1) to "Mains" and rest the body (2) complete with the windings on the insulated portion of the test stand. Insert the ends of the leads into the sockets. Connect one probe to one winding terminal and the other probe to the next terminal.
- Tell-tale (3) will come on if the connection is good.

Insulation check



Fig. 14 4/8 - Checking the Field Coils For Continuity

- Rest the body (2) on the insulated portion of the test stand.
- Turn switch (1) to "Mains" and insert the ends of the leads into the sockets.
- Connect the probes (3) to the body and winding terminal. If telltale (4) comes on, the insulation between the winding and the body is faulty. Renewal of the field coils is dealt with at para 14 4 0520.

Reassembly

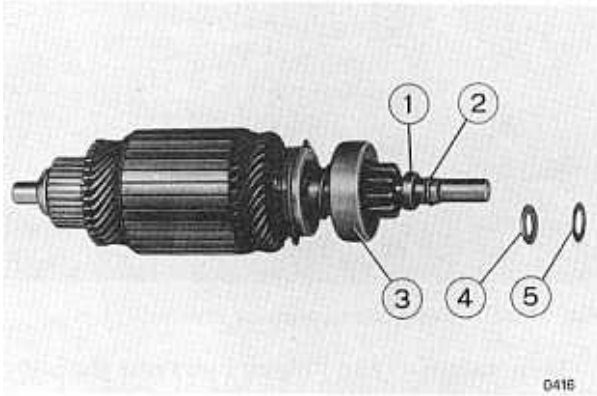

Fig. 14 4/9 - Reassembly of the pinion

- Grease the armature teeth. Mount the pinion. Fit on ring (1).
- Mount the circlip (2) in its seating and lock it with ring (1).
- Use tool 88072008 to mount new bushes on the front and back supports. Mount the cap (8) (see fig. 14 4/1) on the back support and crimp it.

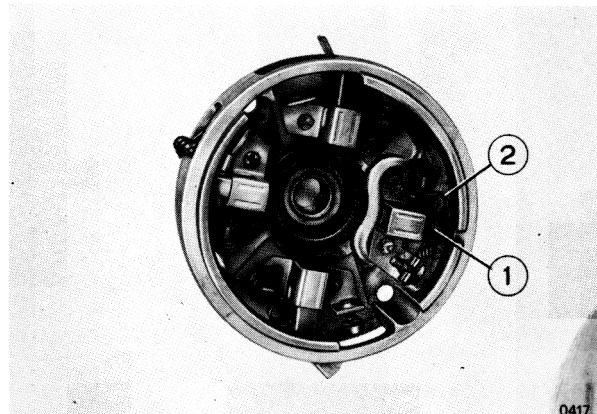

Fig. 14 4/10 Positioning the brushes

- Use the springs (2) to keep the brushes (1) up when mounting them, as shown in the photo.
- Clamp the front support (7) (see fig. 14 4/2) in a lead-jawed vice and remount the armature in the reverse order.
- Slide on the body. Make sure that the reference marks coincide and then position the brush holder. Connect the brush leads to the stator windings. Lower the brushes onto the commutator and remount the dust-excluding collar.

§ 14 4 0520

RENEWING THE STARTER MOTOR FIELD COIL

Disassemble and check as described at para. 14 4 0420 and *proceed as follows*:

- Unscrew bolts holding the pole shoes to the motor body. Slip off the shoes and remove the windings.
- Mount new windings and fit the shoes to the body. Crimp the bolts to lock them in position.
- Reassemble as described at para. 14 4 0420.

§ 14 4 0800

OVERHAUL OF THE ALTERNATOR

After bench testing the alternator as described at para. 16 4 6000, *proceed as follows*:

Disassembly

- Grip the drive sheave in a lead-jawed vice, unscrew the mounting nut and remove the sheave and fan.

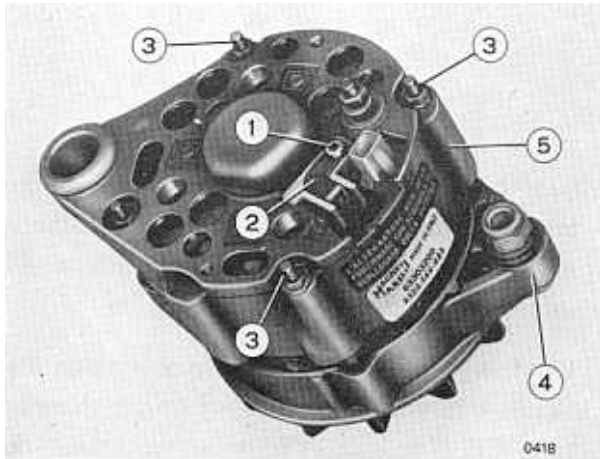

Fig. 14 4/11 - Disassembly of alternator

- Unscrew bolt (1) and remove the brush holder (2). Undo nuts (3) and the frame (4). Slide the rotor from the frame (5).

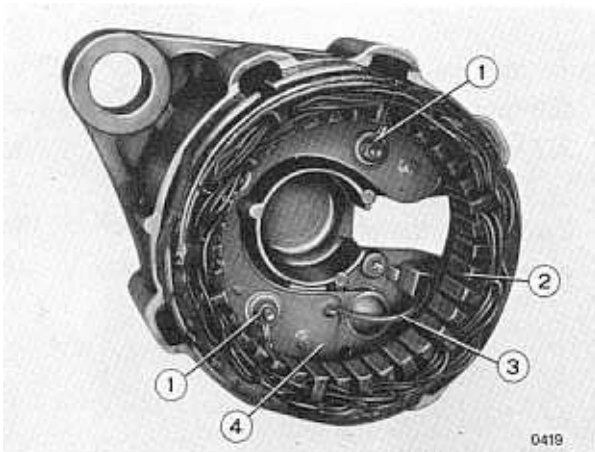

Fig. 14 4/12 - Disassembly of diode holder

- Unscrew nuts (1) and take off the stator (2). Slip off the cable (3) and remove the diode holder (4).
- Testing and overhauling the parts at the bench
- Carefully clean all dismantled parts with a cloth and compressed air
- Check all parts for wear and renew as required

- Check of stator insulation
- Rest the stator on the insulated part of test stand 88075016.
- Turn the switch to "On". Insert the insulation testing lead terminals into the insulation test sockets. Connect one end to a winding terminal and the other and to the segments. If the warning light comes on, this shows that the insulation between the winding and the segments is faulty.
- Check of stator continuity and insulation
- Rest the stator on the insulated part of test stand 88075016.
- Turn the switch to "On". Insert the insulation testing lead terminals into the insulation test sockets. Connect one end to the segments and the other to the three phases of the stator in turn. If the warning light comes on, this shows that the insulation between the winding and the segments is faulty.
- Check of rotor continuity and insulation
- Rest the rotor on the insulated part of test stand 88075016.
- Turn the switch to "On". Connect the lead terminals to the contact rings and check that the warning light comes on, showing that continuity exists.
- Then connect one terminal to one contact ring and the other to the pole shoes or the rotor shaft. If the warning light comes on, this shows that the insulation between the winding and the pole shoes (or rotor shaft) is faulty.
- Check of diode holder.
- Connect the diode holder to the test bench 88075016 by means of the two terminals (see the photo).
- Check that the voltage switch (1) is set to 12 V and turn the main switch to "On". Turn switch (3) first in one direction and then in

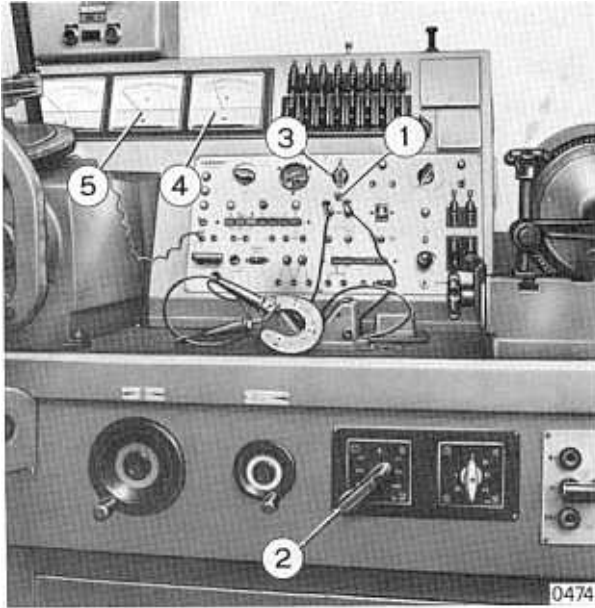

Fig. 14 4/13 - Check of diode holder.

the other. Current should pass in one instance only. If this is not so, the part must be renewed.

Reassembly

- Reassemble in the reverse order and check that the rotor turns freely in both directions.

§ 14 4 0900

RECHARGING THE BATTERY

Proceed as follows:

- Clean the top of the battery thoroughly.
- Remove the caps and check the electrolyte level. Top up with distilled water if necessary.
- Connect the two battery terminals to the respective charger poles and turn on the charging circuit.

Note: the charge current will depend on the battery capacity. It should be about one-tenth of the capacity, i.e. a 45 Amp/hr battery will require about a 4.5 Amp current.

- Use thermometer 88075002 to check that the electrolyte temperature does not rise to more than 40°. If this value is exceeded, reduce the charging current and leave the battery on charge for a longer period.
- Continue charging until there is a brisk flow of bubbles in all the battery cells.

Note: the electrolyte density should be 1.28 at this point and the voltage between 2.6 and 2.7 V in each cell.

- Switch off the charging current. Recheck the electrolyte level and replace the caps.

CHAPTER 2

ELECTRIC SYSTEM

§ 14 2 1000

REMOVING AND REFITTING LIGHTING CLUSTER (right and left)

Fit the covers 88083051 and *proceed as follows*:

Removing

- Turn on the position lights so as to lift the headlights and then disconnect the battery cables.

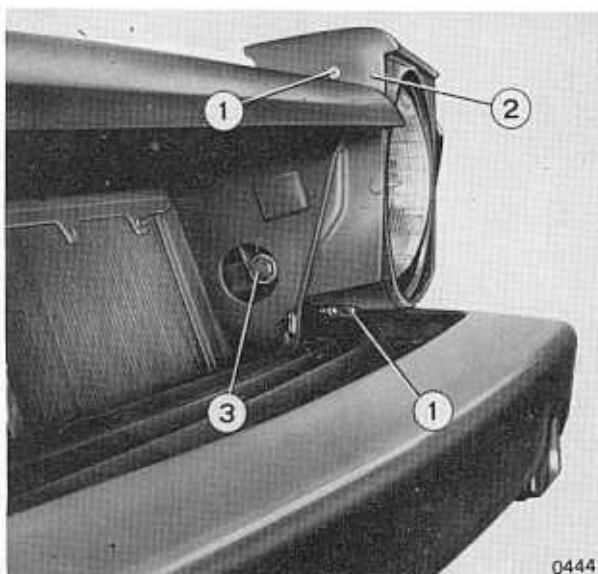

Fig. 14 2/1 - Lighting cluster

- Unfasten the bolts (1) and (2) and remove the framing (3).

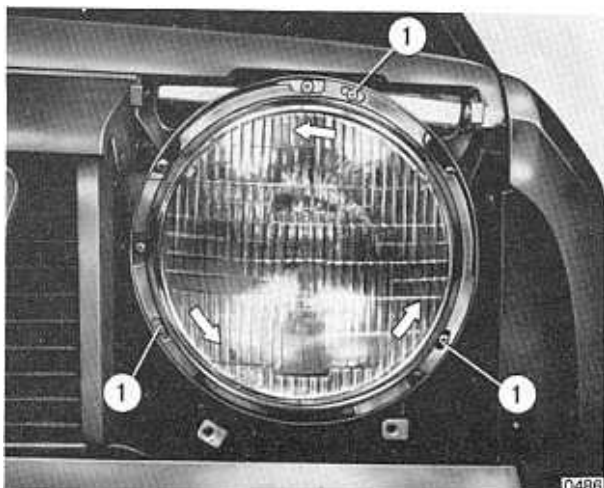

Fig. 14 2/2 - Paraboloid reflector securing bolts.

- Unfasten the bolts (1), rotate the headlight in the direction of the arrow, disconnect the cable and remove the reflector.

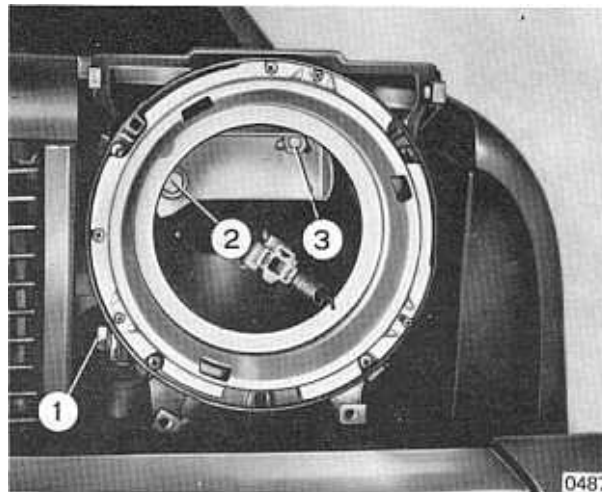

Fig. 14 2/3 - Removing headlight support.

- Unfasten the bolts (1) and (2) working from inside the front bonnet, remove the bolt (3) and take off the support assembly.

Refitting

- Refit in the reverse order to removal, then check headlight aiming as described at 14 2 0100.

§ 14 2 6800

REMOVING AND REFITTING HEADLIGHT LIFTER MOTOR

Fit the covers 88083051 and *proceed as follows*:

Removing

- Turn on the position lights so as to lift the headlights and then disconnect the battery cables.
- Remove the luggage compartment light fitting and the left-hand carpeting.

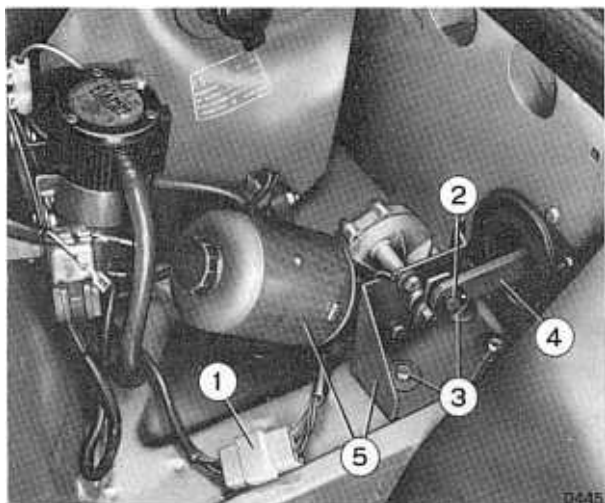

Fig. 14 2/4 - Removing headlight lifter motor.

- Disconnect the bushing (1).
- Withdraw the spring (2), remove the bolts (3) and then free the lever (4) and remove the bracket and motor (5).
- At the bench, detach the motor from its fixing bracket.

Refitting

- Refit in the reverse order to removal.

BASIC MODEL

The directions and operations refer to the bodywork fitted to all car models.

VARIANTS

– **Variant for U.S.A.**

The directions and operations refer to the bodywork fitted to the SCORPION versions only: **137 AS.6**

BODY GROUP CONTENTS

CHAPTER 1

Troubles, probable causes, chackings and operations to be carried out

from page 15 1/1
to page 15 1/3

CHAPTER 2

Plate Glass

§ 15 2 0100	Removing and refitting the windscreen glass	page 15 2/1
§ 15 2 0300	Removing and refitting the rear window glass	" 15 2/2
§ 15 2 0400	Removing and refitting side windows	" 15 2/3

Doors

§ 15 2 0450	Removing and refitting a door trim panel	15 2/5
§ 15 2 0500	Removing and refitting a door drop window	15 2/5
§ 15 2 0560	Removing and refitting quarterlight glass	15 2/6
§ 15 2 0600	Removing and refitting a window regulator	15 2/6
§ 15 2 0800	Removing and refitting a door	15 2/6
§ 15 2 0810	Adjusting a door mounting (setting the hinges, bumper and striker plate)	15 2/7
§ 15 2 0900	Removing and refitting the hinges of a door (including removing and refitting the door)	15 2/9
§ 15 2 1000	Removing and refitting the handle with lock	15 2/9
§ 15 2 1020	Removing and refitting door lock	15 2/9
§ 15 2 1100	Removing and refitting door lock remote control handle and cable	15 2/10
§ 15 2 1130	Adjusting a door remote control cable	15 2/10

§ **Paddings and Seats**

§ 15 2 1900	Removing and refitting the centre console	page	15 2/11
§ 15 2 2200	Removing and refitting seat assembly . . .	"	15 2/11

Bonnet and Lids

§ 15 2 2700	Removing and refitting the bonnet	15 2/13
§ 15 2 2710	Adjusting the set of the bonnet	15 2/13
§ 15 2 2800	Removing and refitting the bonnet release cable and sheath	15 2/13
§ 15 2 3100	Removing and refitting the bonnet hinges	15 2/14
§ 15 2 3700	Removing and refitting the glove locker cover lock	15 2/14
§ 15 2 3900	Removing and refitting the boot lid	15 2/14
§ 15 2 3910	Adjusting the boot lid mounting	15 2/15
§ 15 2 4100	Removing and refitting the boot lid lock	15 2/16
§ 15 2 4110	Adjusting the boot lid catch	15 2/16
§ 15 2 4410	Removing and refitting the boot lid release cable and sheath	15 2/16

Bumpers and Mouldings

§ 15 2 5500	Removing and refitting the radiator grille	15 2/17	
§ 15 2 5600	Removing and refitting the right, or left gutter	15 2/17	
§ 15 2 5700	Removing and refitting the front bumper assembly	15 2/17	
	Do. for SCORPION cars	15 2/1	Variant SCORPION
§ 15 2 5740	Removing and refitting front bumper shock absorbers	15 2/1	Variant SCORPION
§ 15 2 5900	Removing and refitting the rear bumper	15 2/17	
	Do. for SCORPION cars	15 2/2	Variant SCORPION
§ 15 2 5940	Removing and refitting rear bumper shock absorbers	15 2/2	Variant SCORPION
§ 15 2 6200	Renewal of rear grille	15 2/18	

Sun Roof

§ 15 2 7300	Removing and refitting side wing	15 2/19
§ 15 2 7200	Removing and refitting soft sun roof	15 2/19
§ 15 2 8000	Removing and refitting soft sun roof	15 2/19
§ 15 2 3100	Removing and refitting the soft top opening catch	15 2/20

FAULT	PROBABLE CAUSE	CHECKS ADVISABLE BEFORE REPAIRING	ACTION NECESSARY	PARA
Seepage of water via windscreen	Sealer perished or has air bubbles. Loss of water-tightness	—	Use gun 88083065 to insert a rope of sealer 88624250 where the water is presumably entering	—
Seepage of water via rear window	Sealer perished or has air bubbles. Loss of water-tightness	—	Use gun 88083065 to insert a rope of sealer 88624250 where the water is presumably entering	—
Seepage of water via rear side window	Sealer perished or has air bubbles. Loss of water-tightness	—	Use gun 88083065 to insert a rope of sealer where the water is presumably entering	—
Difficulty in operating window winder	Faulty winder mechanism	—	Removal and refitting of window winder mechanism	15 2 0600
Difficulty in closing front door	Door incorrectly adjusted	—	Adjustment of front door	15 2 0810
Faulty operation of front door handle	Defective handle lock cylinder	—	Removal and refitting of front door handle with lock	15 2 1000

FAULT	PROBABLE CAUSES	CHECKS ADVISABLE BEFORE REPAIRING	ACTION NECESSARY	PARA
Inside front door lever does not work or works incorrectly	Cable incorrectly adjusted	—	Adjustment of inside door opening lever	15 2 1130
	Faulty lever	—	Removal and refitting of inside door opening lever	15 2 1100
Door safety catch unreliable	Faulty safety catch lever or cable	—	Renewal of door safety catch lever and cable	—
Front seats do not slide easily or cannot be kept still	Distorted runners or broken locating lever spring	—	Removal and refitting of a front seat	15 2 2200
	Incorrectly mounted bonnet	—	Adjustment of bonnet	15 2 2710
Bonnet release lever does not work properly	Cable stuck inside the sheath, or incorrectly adjusted	—	Removal and refitting of bonnet release lever cable and sheath	15 2 2800
Glove locker lid does not close properly	Defective lid lock	—	Removal and refitting of glove locker lid	15 2 3700

FAULT	PROBABLE CAUSES	CHECKS ADVISABLE BEFORE REPAIRING	ACTION NECESSARY	PARA
Difficulty in closing boot lid	Boot lid incorrectly mounted	—	Adjustment of boot lid	15 2 3910
	Defective or incorrectly adjusted boot lock or lock control	—	Removal and refitting of boot lid lock Adjustment of boot lid catch	15 2 4100 15 2 4110
Difficulty in opening boot lid	Defective or incorrectly adjusted boot lid catch control	—	Removal and refitting of boot lid catch control Adjustment of catch	— 15 2 4110

CHAPTER 2

PLATE GLASS

§ 15 2 0100

REMOVING AND REFITTING THE WINDSCREEN GLASS

Fit the covers 88083051-88083056-88083058
and *proceed as follows*:

Removing

- Remove levers and windscreen wiper blades as described at 13 2 2500, unfasten screws (1) and (2) securing sun visor supports and remove, take the rear-view mirror from its housing (4); detach the interior cover (3) by forcing it away from its retaining springs.

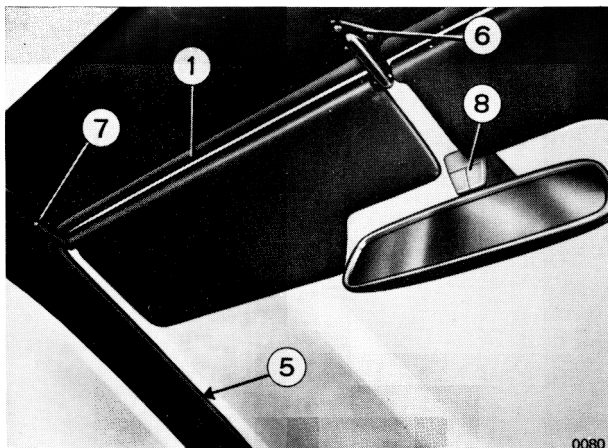

Fig. 15 2/1 - Windscreen glass.

- Protect the outside edge of the glass seating with adhesive paper, use a knife or special tool to remove about 2 cm of Solbit (from the outside of the windscreen); insert a length of piano wire of diameter 0.5-0.7 mm between glass (1) and seating (2), apply two handles to the ends. Two mechanics, one inside and one outside the car, should then cut the strip of sealant by sawing the wire back and forth.

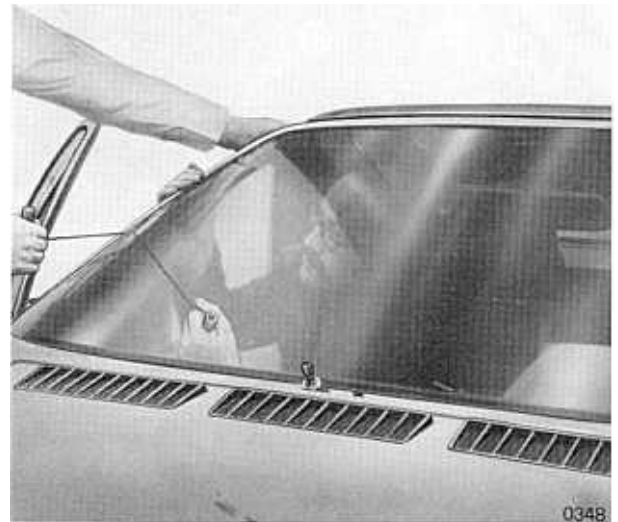

Fig. 15 2/2 - Removing windscreen glass.

Note: if the wire meets any particular resistance during this operation, do not insist so as not to run the risk of damaging the pane or design work (3), and fit the wire at another point.

- Remove the glass; remove the interior and upper trim retainers and use a knife to scrape away from the seating as much residual adhesive as possible; clean the seating thoroughly with a rag soaked in a solvent that does not damage paintwork.
- With a brush, spread glue along the interior part of the pillars and crosspiece and glue on padding and headlining; fit headlining and side pillar padding retainers and then fit the trim retainers, the trim itself and the joint cap.
- Fit the windscreen glass into its seating (4) after inserting rubber spacers (2) designed to leave a uniform distance between glass perimeter and the seating (4).
- Check that the glass is fitted tightly all round the rim; if it is not, fit rubber spacers which will sink in the silicon sealant.
- Once the glass is perfectly centred, apply adhesive tape spacers (3) and snip them off at the edge of the glass so that they form

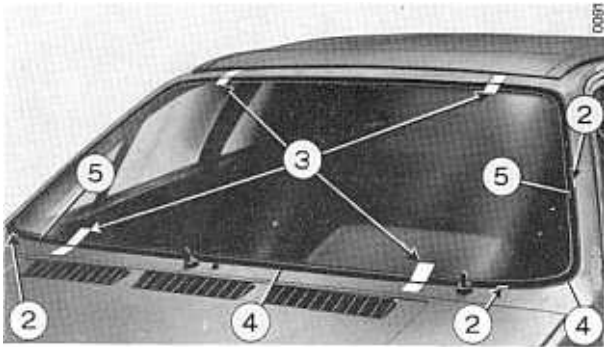

Fig. 15 2/3 - Centering windscreen glass.

reference points for the final position of the glass after sealant has been applied.

- Remove the glass and, using a brush and a non-lint cloth, apply a coat of primer along the glass seating and the edge of the glass (no greater than 15 mm width).
- Using a compressed air gun (part 88083062) form a bead of silicon sealant of diameter 8-10 mm. along the whole seating (to achieve a uniform cord of this diameter, cut the beak that screws on to the cartridge at the first notch and regulate the gun retraction speed and meter air pressure using the trigger).
- Fit the glass into its seating, check that the adhesive reference strips are in line and then apply fixture 88083067 and leave it for 25 hours; before the silicon sealant has polymerized, trim protruding adhesive along the edge of the shell using a wooden or plastic putty knife.

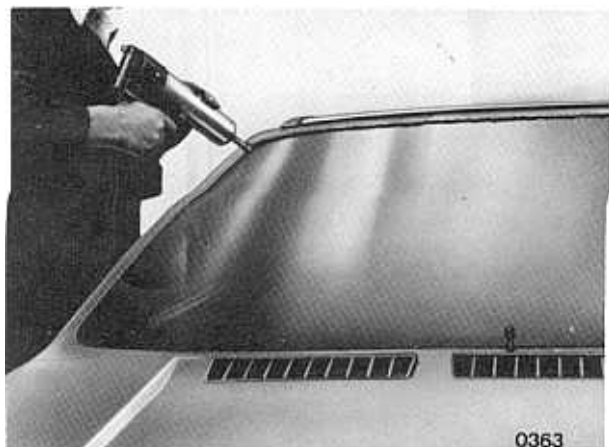

Fig. 15 2/4 - Applying silicon sealant.

- Check the whole adhesion surface between sealant and glass (5) which should be uniform and smooth; where depressions are encountered, even them out with sealant as shown in fig. 15 2/4.
- Check that no adhesive is left inside the car between the glass and the trim; any excess should be eliminated, being careful not to scratch the black design work on the glass.

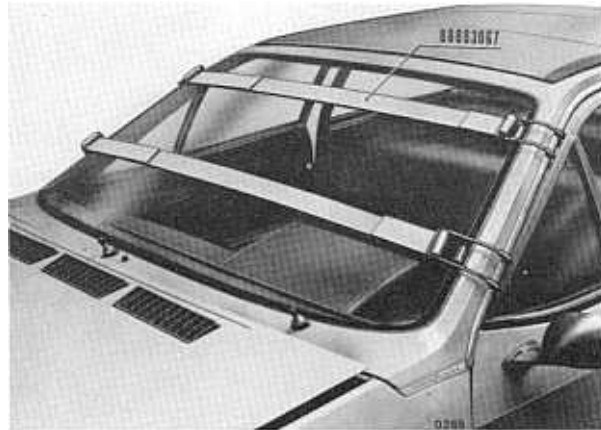

Fig. 15 2/5 - Using fixture 88083067.

- When the operation is finished, clean glass and body-shell surfaces using a solvent which does not damage paint, or a heptane-soaked flock of cotton.

TOOLS REQUIRED

- 88083062 - Compressed air gun
- 88083067 - Tool

§ 15 2 0300

REMOVING AND REFITTING THE REAR WINDOW GLASS

Proceed as follows:

Removing

- Detach the positive battery cable, remove the front seats, fold over the rear oddments shelf (9) as shown in the figure; remove the dome lights (3) and disconnect the earth cables, remove the door rabbet cover (8) and the rear

pillar interior trim (4).

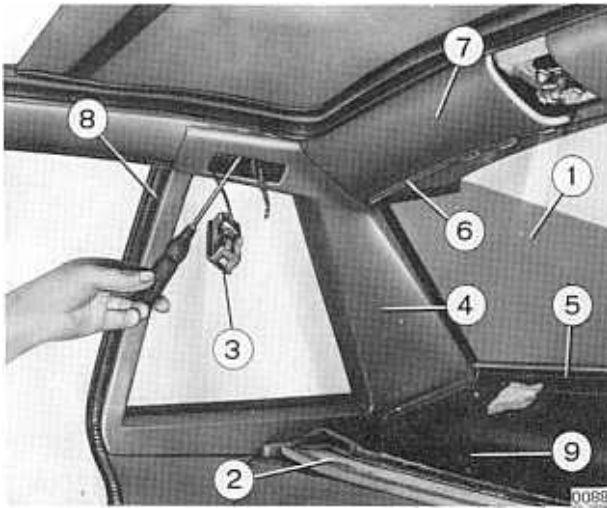

Fig. 15 2/6 - Removing guards.

- Take down the interior framework (5), extract the sun roof control handle, remove the handle plate, take down the rear crosspiece padding (7) and push the upper strip (6) away from the sealant.
- Remove the bonnet as described at 15 2 2700, the spare wheel and the water tank.
- Remove the moulding on the rear quarter panels, the air outlet grilles on the pillars and the two wings as described at 15 2 7300.
- Using a suitable knife or tool, scrape away the adhesive between the rear window and its seating, then remove the rear window glass in the same way as the windscreen.
- Prepare the glass seating, centre it and apply spacers as described for the windscreen.
- Glue spacers and distance pieces in the rear window seating, apply the bead of silicon sealant on the glass seating and round the edge of the glass in the same way as has been described for the windscreen; fit the glass into its seating and apply gluing fixture 88083056 a.



Fig. 15 2/7 - Rear window adhesion fixture.

- Set the upper moulding (part 6 of fig. 15 2/6) in the sealant; trim the edge of the glass with a putty knife and if necessary remove excess sealant from inside the car.
- After 24 hours, remove the adhesion fixture, carefully clean the glass the surrounding areas of sealant residue, then refit all the parts removed.

TOOLS REQUIRED

- 88083066 a - Tool

§ 15 2 0400

REMOVING AND REFITTING SIDE WINDOWS

Proceed as follows:

Removing

- Working inside the engine compartment, remove the nuts holding the moulding of the quarter panel concerned and take off the outside framework of the side window, strip off the door weatherstrip (8) and complete seat.
- Remove the dome light (3) and respective cabling, fold the trim (2) as shown in the figure; remove interior pillar trim (2) as shown in the figure; remove interior pillar trim (4).

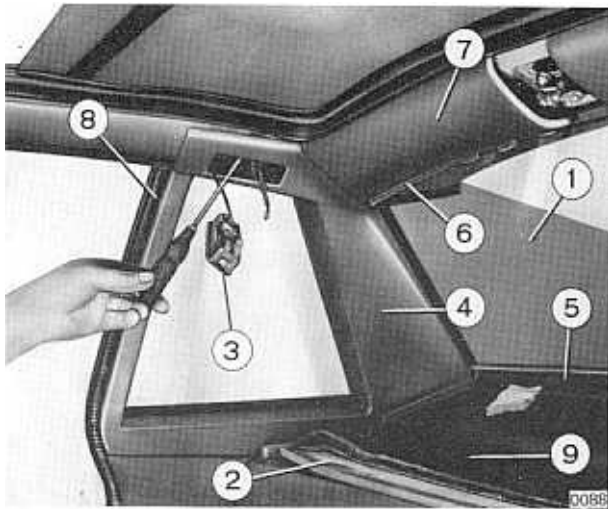

Fig. 15 2/8 - Parts to be removed inside the car.

Take out the glass as described at 15 2 0200.

Prepare the glass, the seating, centering and spacing as described at 15 2 0300 and make sure that there is a constant clearance of 3 mm between the glass and its seating.

Glue as described for the windscreen, apply fixture 88083056 b and leave standing for 24 hours.

- Trim excess sealant, clean the glass and refit all parts removed in the reverse order.



Fig. 15 2/9 - Side window adhesion fixture.

TOOLS REQUIRED

- 88083066 b - Side window adhesion fixture.

DOOR

§ 15 2 0500

§ 15 2 0450

REMOVING AND REFITTING A DOOR TRIM
PANEL

Proceed as follows:

Removing

- Unscrew the bolt (6) holding the locking knob and take this off; remove the bolts securing the upper armrest and dashboard extension (3) and remove it.
- Unscrew the two bolts securing the armrest (5); using a screwdriver, lever the window control handle (4) away from its seat, remove the retainer and then take off the window control handle.
- Remove the door trim as shown by the arrows.

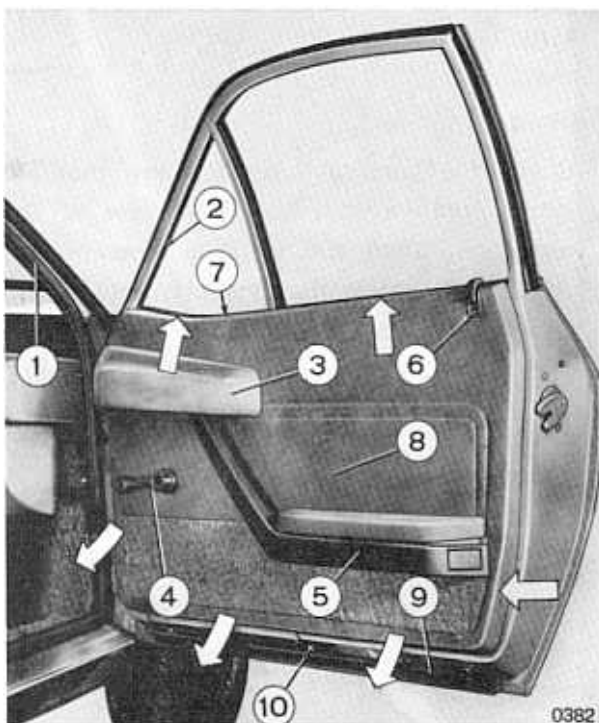

Fig. 15 2/10 - Complete door.

Refitting

- Refit in the reverse order to the removal, making sure that the edge of the seal (7) covers the panel at the top.

REMOVING AND REFITTING A DOOR DROP
WINDOW

Proceed as follows:

Removing

- Remove the door trim panel as described at 15 2 0450, remove the plastic protections, and take off the handle rod (7); unscrew the bolt (5), take off the spring (6) and remove the lock rod (4) from the spring; remove the glass run (9).

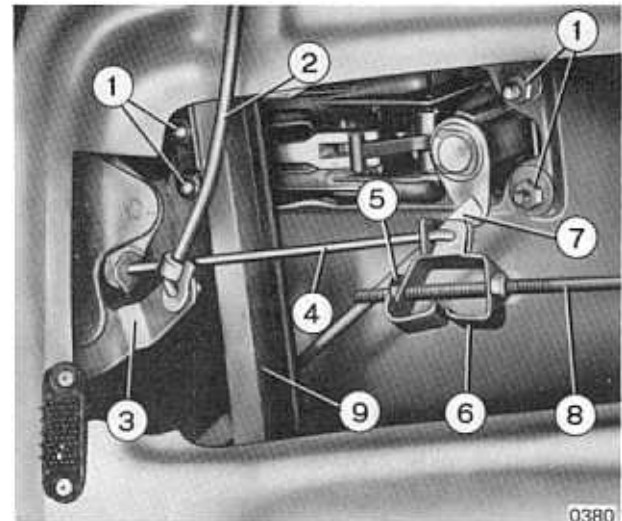

Fig. 15 2/11 - Partial view of door.

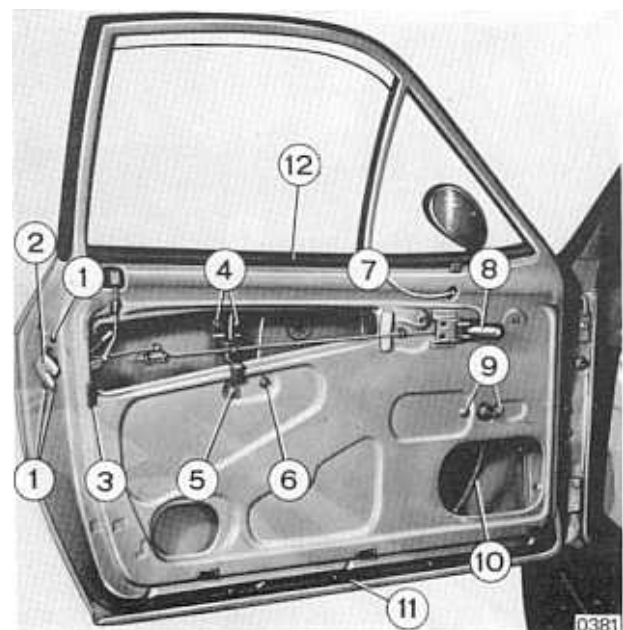

Fig. 15 2/12 - Door.

- Remove bolts (1) securing the lock, adjust part (2) and extract the lock from its recess; remove bolts (5), (6), (9) securing the window regulator and remove it complete with piping (10), support the glass and remove it from its recess with...
- If the glass has to be replaced, remove the support and refit it to the new glass.

Refitting

- Refit in the reverse order and check that the window regulator is working correctly.

§ 15 2 0550

REMOVING AND REFITTING QUARTER-LIGHT GLASS

After removing the door trim panel as described at 15 2 0450, *proceed as follows:*

Removing

- Remove screw (7) (fig. 15 2/12) securing the quarter-light run, then push the glass downwards and remove it. (If this is not possible immediately, ease out the quarter light trim with a blade).
- Check the weatherstrip (1) and if it is worn replace it.



Fig. 15 2/13 - Fitting quarter-light glass.

Refitting

- Spread a thin coating of vaseline over the quarter-light seating, then refit the glass as shown in the figure.
- When the work is completed, check that a few mm of the contour trim lie on the glass.

§ 15 2 0600

REMOVING AND REFITTING A WINDOW REGULATOR (for refs. see fig. 15 2/12)**Removing**

- Remove the door trim panel as described at 15 2 0450; make sure the glass is fixed tight and remove the bolts (4) holding the glass support.
- Remove the plastic protections, unfasten the two bolts (9) holding the regulator handle and take out the regulator complete with cable (10).

Refitting

- Check the parts and replace any that are worn; apply a thin coat of grease to the regulator. When the refitting operation is completed, check that the glass opens and closes perfectly.

§ 15 2 0800

REMOVING AND REFITTING A DOOR (setting the hinges, bumper and striker plate)**Removing**

- Lift the weatherstrip as shown in the figure, mark the position of the hinges on the pillar, remove the six bolts (1) and (4) holding the hinges to the pillar and then remove the door; this operation has to be carried out by two fitters, one of whom holds the door while the other removes the hinge bolts.

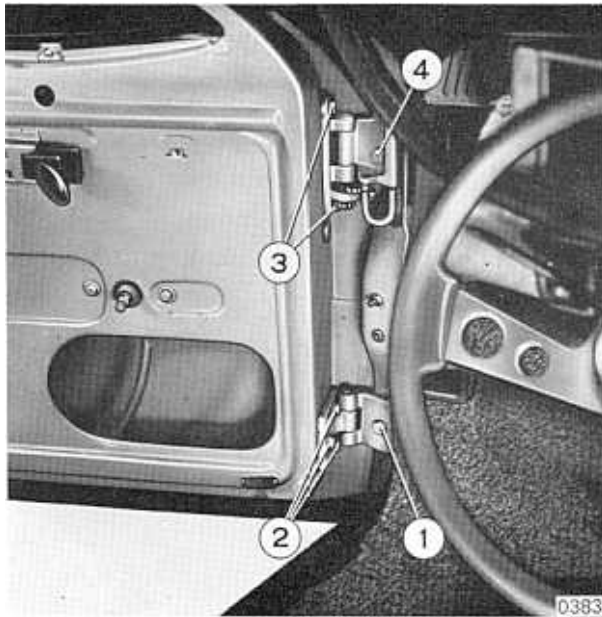

Fig. 15 2/14 - Door with hinges

Refitting

Refit the door screwing in the hinge bolts without tightening them; check that the door opens and closes correctly without effort. If any difficulty is encountered, adjust the position of the hinges to eliminate the problem (1).

Tighten the hinge screws and complete refitting in the reverse order to removal.

(1) If the door cannot be positioned correctly by simply shifting the hinges, adjust the rear door as described at 15 2 0810 to ensure perfect closing.

§ 15 2 0810

ADJUSTING A DOOR MOUNTING (setting the hinges, bumper and striker plate).

Proceed as follows.

– With the door closed or, if necessary, by opening and closing it, check that clearance along the door contour is even, that the door does not protrude too much, is not over-recessed with respect to the side and quarter panel and that it closes smoothly.

– The following faults might be encountered during this control:

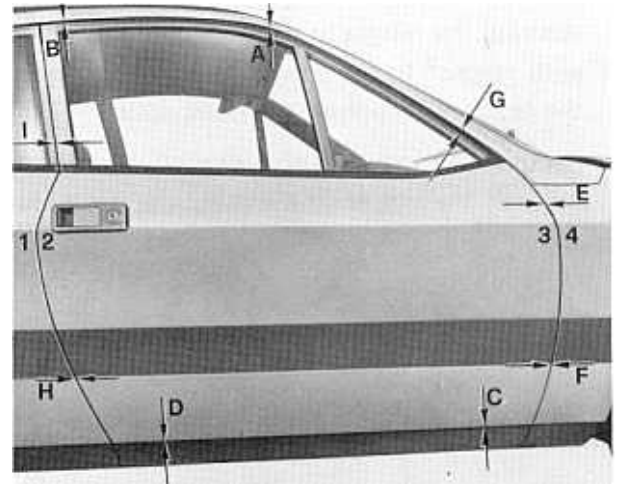

Fig. 15 2/15 - Adjusting the door mounting.

- 1) Clearance between points (A-B) is greater or less than that between points (C-D); this could be due to improper setting of the hinges fixed to the door.
- 2) Clearance at point (A) is greater than at point (C) and thus the distance at point (E) is less than at point (F) and the waist line is irregular. This fault is probably due to incorrect setting of the door which has been "turned" too much when being fitted to the hinges.
- 3) Clearance at points (G-E-F) is greater or less than at points (H-I). This fault may be due to incorrect horizontal fitting of the door. In extreme cases, points (1-2) might interfere with door opening.
- 4) The door protrudes too much at points (1-4) or is over-recessed at points (2-3).
The reason is incorrect setting of the hinges fixed to the body pillars.
- 5) The edge (3) of the door is not in line with the edge (4) of the side; the waist line is thus broken. The reason is incorrect setting of the striker plate or the hinges.
- 6) It is hard to close the door even though alignment and contour clearance are normal. The fault is due to incorrect setting of the striker plate or the spacers.

To eliminate the faults noted at points (1) - (2) - (3) - (4), *proceed as follows:*

- Remove the door trim panel; slacken the bolts securing the hinges to the door, shift the door with respect to the hinges so as to get rid of the faults, then tighten the bolts again.
- If this is not enough, slacken the bolts securing the hinges to the pillar and move the

hinges until the faults have been eliminated; then tighten the bolts and check that the faults have in fact been removed.

- To eliminate the faults noted at points (5) and (6), work directly on the striker plate or spacers, slackening the mounting bolts or increasing or reducing the number of spacers.

DOORS

§ 15 2 0900

REMOVING AND REFITTING THE HINGES OF A DOOR (INCLUDING REMOVING AND REFITTING THE DOOR) (For refs. see fig. 15 2/10)

Proceed as follows:

Removal

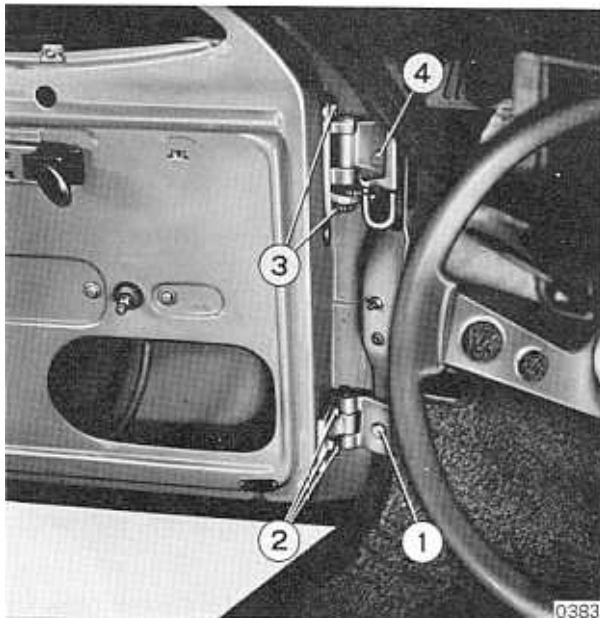

Fig. 15 2/16 - Removal hinges

- Remove the door as described at 15 2 0800; at the bench, mark the position of the hinges on the door with a pencil, remove the bolts (2) and (3) and take off the hinges.

Refitting

- Refit the hinges in the reverse order to the removal as described at 15 2 0800.

§ 15 2 1000

REMOVING AND REFITTING THE HANDLE WITH LOCK

Proceed as follows:

Removal

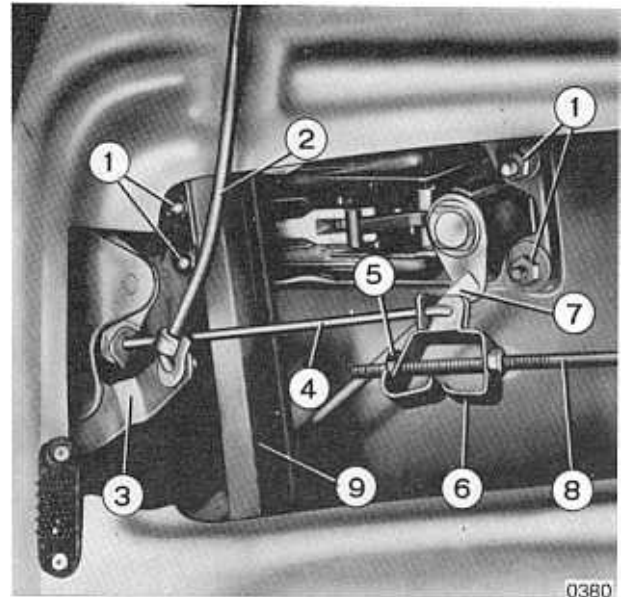

Fig. 15 2/17 - Door handle and lock.

- Remove the door trim panel (15 2 0450), disconnect the inside locking rod (7) from the pawl, remove the securing bolts and take off the side channel (9).
- Unfasten the nuts (1) securing the handle and remove it.

At the bench

- Withdraw the lock ring (10), the washer, the pawl, the second spring washer, and the pawl return spring and remove the lock cylinder.

Refitting

- Refit in the reverse order to the removal; test lock function by working the handle and complete the operation by refitting the door trim panel.

§ 15 2 1020

REMOVING AND REFITTING DOOR LOCK

After removing the door trim panel as described at 15 2 0450, *proceed as follows:*

Removing

- Remove the plastic protection covering the recess with.

Remove the bolts (1) securing the lock (2), and turn it so that it can be taken out of the recess with.

Slacken the nut (5) and withdraw the cable (4) and (7).

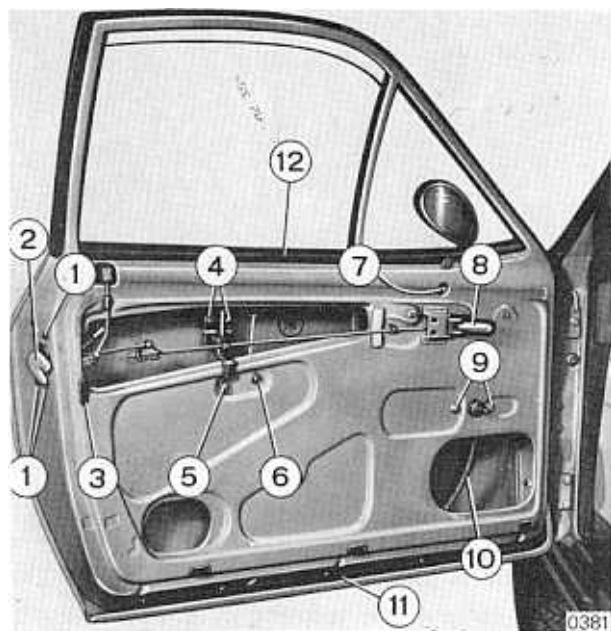

Fig. 15 2/18 - Door

Refitting

- Set the lock in its seating and secure with bolts, reconnect the control cable (4), screw in the nut (5) and check the operation of the inside remote control mechanism (8) (fig. 15 2/18), adjusting it if necessary.
- Refit all remaining parts in the reverse order to the removal.

§ 15 2 1100

REMOVING AND REFITTING DOOR LOCK REMOTE CONTROL HANDLE AND CABLE

After removing the door trim panel as described at 15 2 0450, *proceed as follows*:

Removing

- With reference to Fig. 15 2/18
- Remove the plastic protection from the recess with reference to Fig. 15 2/19.

- Unfasten the setting nut (5) withdraw the spring (6) and free the control cable (8)
- Remove the bolts securing the door remote control, open the two plastic retainers indicated by the arrows and withdraw the control (8) complete with cable.

Refitting

- Refit all the parts in the reverse order; before refitting the panel, check that the door opening control is working correctly; if it is not, adjust the cable travel
- Complete the operation by refitting the panel

§ 15 2 1130

ADJUSTING A DOOR REMOTE CONTROL CABLE

After removing the door trim panel as described at 15 2 0450, *proceed as follows*:

- Loosen the nut (11) and hence the spring (6) and tighten nut (5); the cable (8) remains under tension and places lever (4) under tension also.
- The lock is released from the striker plate by raising the inside door handle.

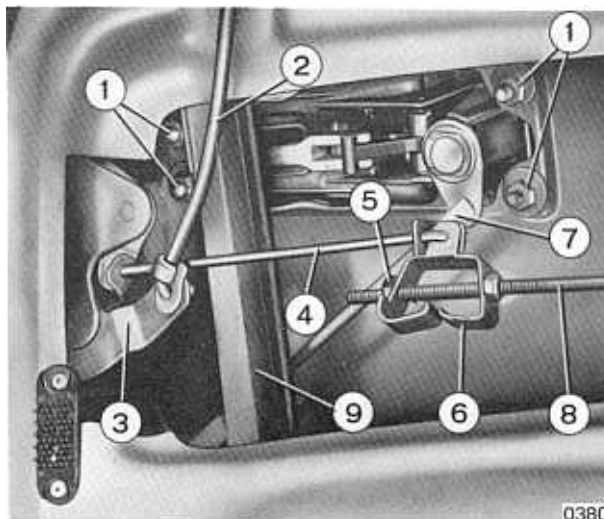

Fig. 15 2/20 - Lock and controls assembly.

- Refit all parts removed in the reverse order.

PADDINGS AND SEATS

§ 15 2 2100

REMOVING AND REFITTING THE CENTRE CONSOLE

Fit the covers 88083056 and 88083058 and proceed as follows:

Removing

- Remove the positive cable of the battery, remove the knob (1) and lock nut (12), unfasten the bolt (3) and take off the tunnel covering (2).

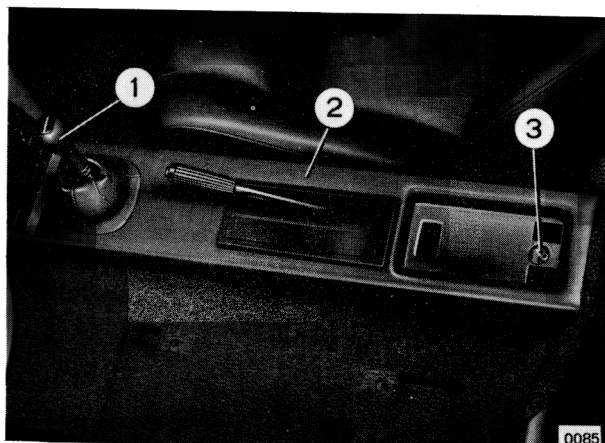

Fig. 15 2/21 - Removing tunnel covering.

- Remove the three bolts securing the left side of the console, open the glove locker and remove the air intake knob; remove the two bolts securing the glove locker, withdraw the locker lighting bayonet fitting and detach the earth cable.
- Remove the bolt securing the centre of the console to the tunnel, and remove the nut securing the upper bracket of the console to the instrument panel (1).
- Withdraw the three control lever knobs, remove the right side securing bolt (2) and the bolts (3) securing the heater control support (4), then pull back the console (5).
- Remove the bayonet fitting for ashtray light cable, the cigarette lighter cables,

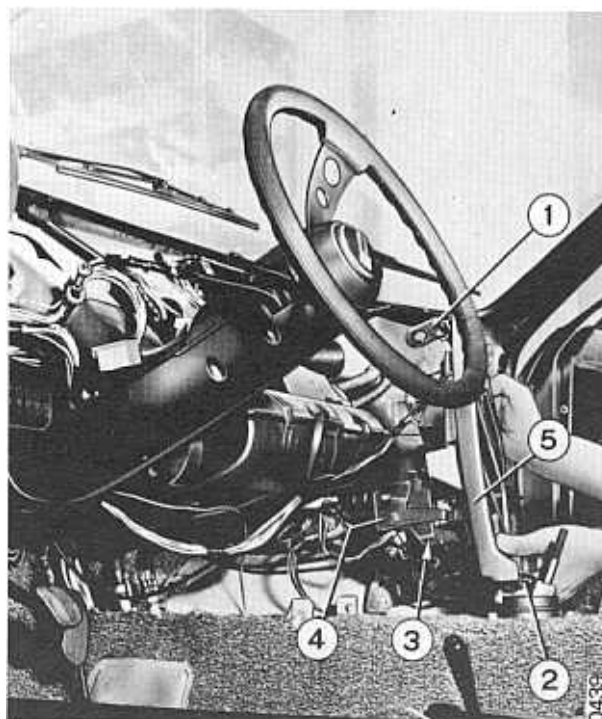

Fig. 15 2/22 - Centre console.

the clock cables and withdraw the electric light bulb.

Refitting

- Refit in the reverse order, taking care to reconnect electric cables correctly. When the operation has been completed, check that all controls and electric parts are working correctly.

§ 15 2 2200

REMOVING AND REFITTING SEAT ASSEMBLY

Proceed as follows:

Removing

- Unfasten the front and rear bolts securing the seat runners to the floor, moving the seat forwards and backwards to make it easier. Remove the seat from the compartment.

Refitting

- Refit in the reverse order.

BONNET AND LIDS

§ 15 2 2700

REMOVING AND REFITTING THE BONNET

Fit covers 88083051 and *proceed as follows:*

Removal

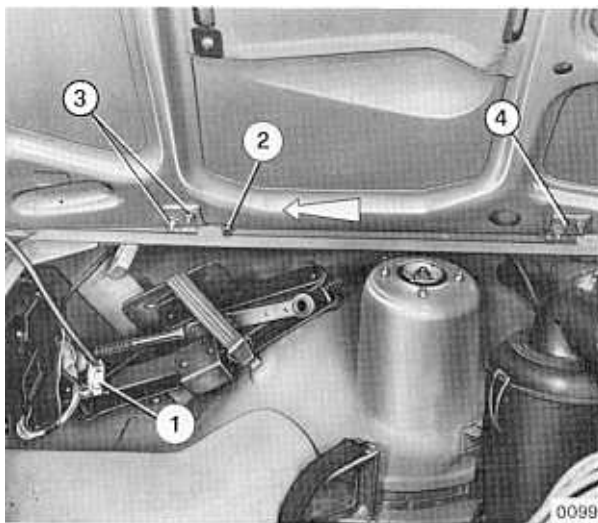

Fig. 15 2/23 - Bonnet.

- Slide off the number plate lights snap fitting (1), unscrew nut (2) and take off the bonnet, complete with its hinge pins.

Refitting

- Reassemble in the reverse order. If necessary, adjust the distances between the bonnet and the body shell as described at para 15 2 2710.

§ 15 2 2710

ADJUSTING THE SET OF THE BONNET

Proceed as follows:

- Check that the gap (A-B) between the bonnet and the edge is even all the way round. If this is not so, slacken the nut holding the hinges. Shift the bonnet to the required position and fix it temporarily in place by tightening nuts

(3) of fig. 15 2/23.



Fig. 15 2/24 - Adjusting bonnet.

- Close the bonnet and check its set. If satisfactory, tighten the nuts (4) right down.
- The bonnet should be able to be opened and closed without undue effort. Adjustments can be made by changing the position of the closing device (fig. 15 2/19) in the slots provided for its attachment to the body shell.

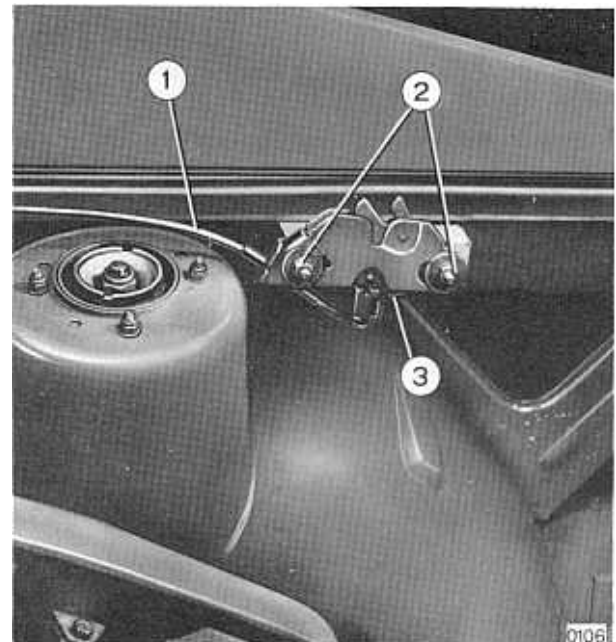

Fig. 15 2/25 - Rear closing device for bonnet.

§ 15 2 2800

REMOVING AND REFITTING THE BONNET RELEASE CABLE AND SHEATH

Fit covers 88083051 and 88083056 and *proceed as follows:*

Removal

- Detach the cable from the lock
- From inside the vehicle, unscrew the bolt holding the assembly to the body and remove, complete with sheath and cable.

Refitting

- Reassemble in the reverse order and check that the opening mechanism works properly.

§ 15 2 3100

REMOVING AND REFITTING THE BONNET HINGES

Fit covers 88083051 and *proceed as follows:*

Removal

that they fit with the marks made on removal. Return the bonnet to its place and if necessary, adjust its position as described at para 15 2 2710.

§ 15 2 3700

REMOVING AND REFITTING THE GLOVE LOCKER COVER LOCK

Fit covers 88083056 and 88083058 and *proceed as follows:*

Removal

- Open the glove locker cover. Unscrew the bolts holding the lock to the cover and remove the lock.

Refitting

- Reassemble in the reverse order. Check that the lock closes properly.

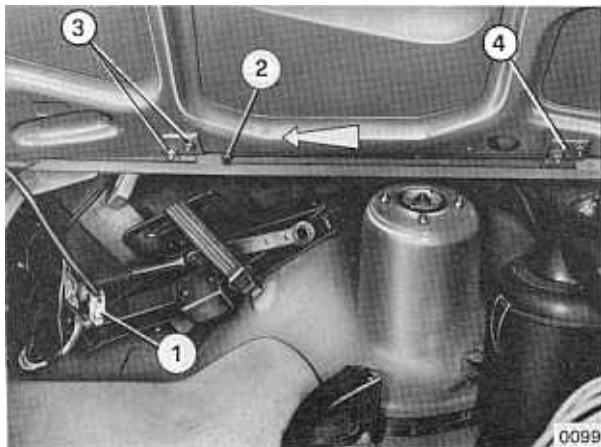

Fig. 15 2/26- Bonnet.

- Remove the bonnet as described at para. 15 2 2700 and unscrew nuts (4). Before detaching the hinges mark their position to make reassembly easier. Remove the hinges (3).

Refitting

- Remount new hinges in the reverse order so

§ 15 2 3900

REMOVING AND REFITTING THE BOOT LID

Proceed as follows:

For references, see fig. 15 2/27

Removal

- Slide off the snap rings (1), unhook the spring (2), extract pins (3) from the hinges (4), and remove the lid. Two persons are needed for this operation.

At the bench

- Remove the air intake strips (5) and the two screws holding the support arm block (6).

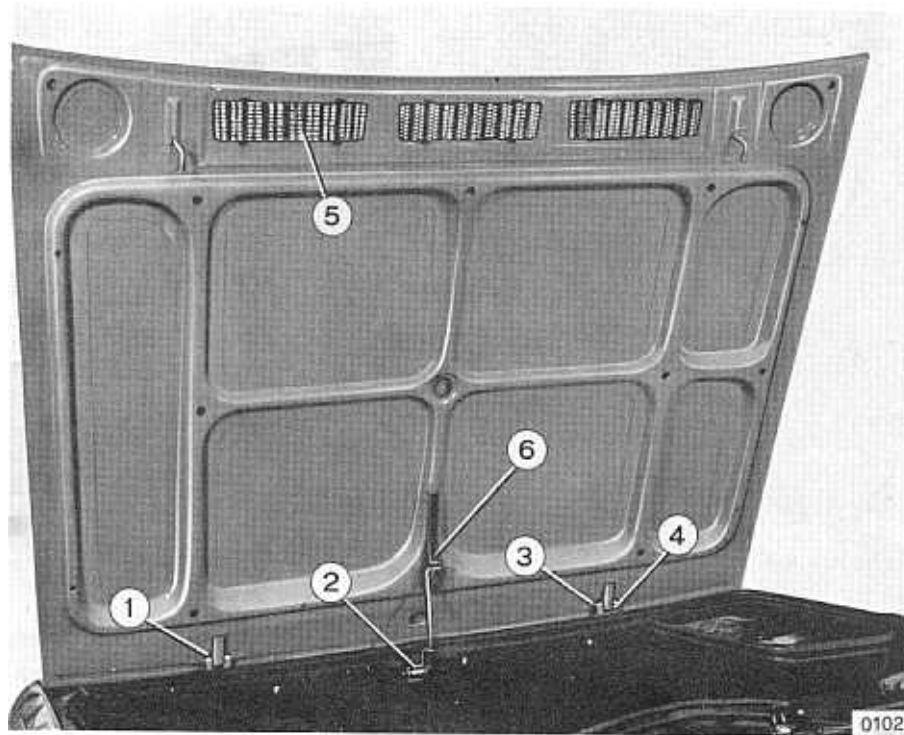

Fig. 15 2/27 - Boot lid

Refitting

Reassemble in the reverse order. Check that the lid is properly set in position. If necessary, adjust as described at para 15 2 3910.

§ 15 2 3910

ADJUSTING THE BOOT LID MOUNTING

Proceed as follows:

- Check that the gap (C-D) and (C'-D') between the lid and the quarter panels is even; the gap between points (E-F) and (E'-F') should be the same as that between points (A-B) and (A'-B').
- Check that point (1) of the quarter panel is in perfect line with point (2) of the lid and that one surface does not protrude with respect to the other.
- To eliminate the faults that might be encountered at point 1, adjust the hinges by slackening the lock bolts (2) and (3), or by

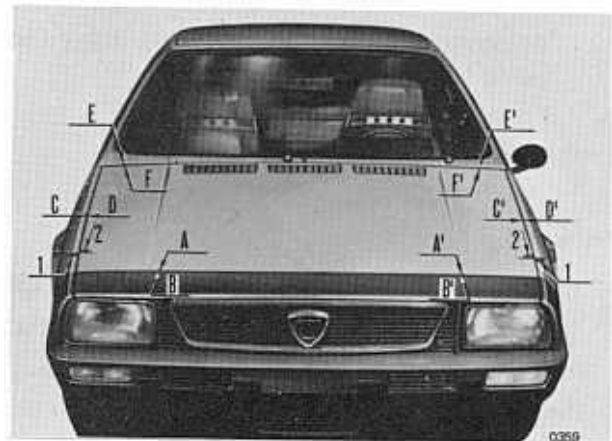

Fig. 15 2/28

removing or adding spacers (1) until the specified condition is achieved.

- To eliminate faults that might arise at point 2, adjust the lid brackets or increase or reduce the spacers of the two locks until the condition specified at point 2 is achieved.

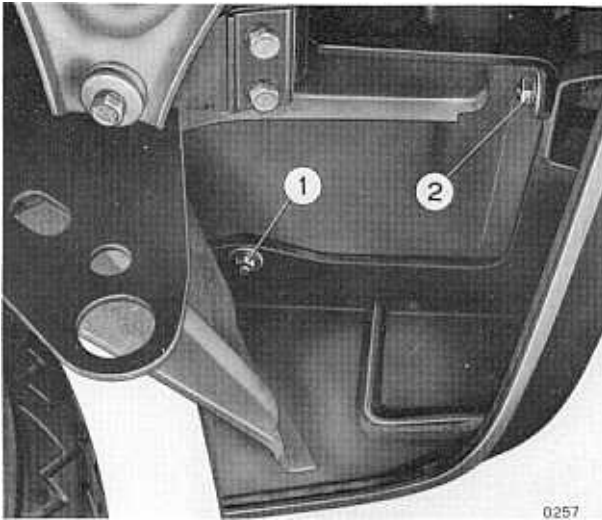

Fig. 15 2/29 - Front lid bracket.

- When the adjustment has been completed, tighten any nuts and bolts that have been slackened.

§ 15 2 4100

REMOVING AND REFITTING THE BOOT LID LOCK

For references, see 15 2/30

Proceed as follows:

Removing

- Open the boot lid, remove the two nuts (8) that secure the tie rod (9) to the two locks; remove the two bolts with nuts (6) securing the locks to the windscreen lower crosspiece, then remove the locks.

Refitting

- Refit the locks to the crosspiece without tightening the nuts (6), lock the two nuts (8) securing the tie rod, and adjust as described at 15 2 4110.

§ 15 2 4110

ADJUSTING THE BOOT LID CATCH

Proceed as follows:

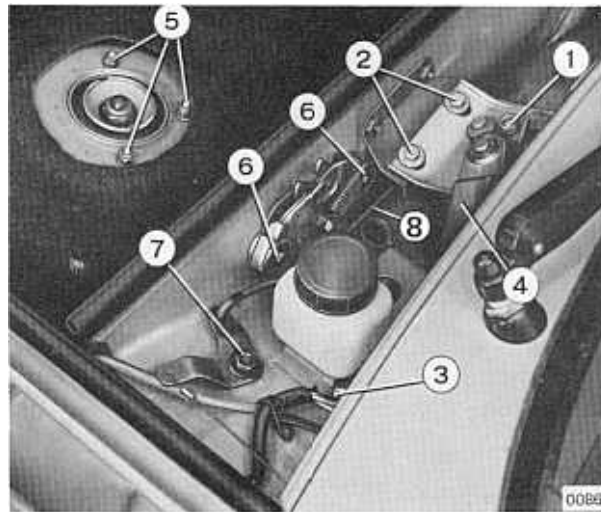

Fig. 15 2/30 - Boot lid lock.

- Check that the hooks on the lid fit perfectly into the lock seats and are centred; otherwise loosen the bolts with nuts securing the locks and adjust as necessary.
- Finally, check that lock springs (9) are strong enough to lift the lid slightly when the lever is released, then screw in the bolts and nuts (6).

§ 15 2 4410

REMOVING AND REFITTING THE BOOT LID RELEASE CABLE AND SHEATH

Fit covers 88083051 and 88083056 and *proceed as follows:*

Removal

- From inside the boot, take off the cable from the recall mechanism. From inside the vehicle, unscrew the bolt holding the assembly to the body shell and remove the same, complete with sheath.

Refitting

- Reassemble in the reverse order. Check that the opening mechanism works properly.

BUMPERS AND MOULDINGS

§ 15 2 5700

§ 15 2 5500

REMOVING AND REFITTING THE RADIATOR GRILLE OR RENEWAL OF THE MOULDING OR BADGE

Proceed as follows:

Removal

- Undo the bolts holding the grille to the body and take off the grille, complete with moulding and badge.

At the bench

- Undo the nuts holding the moulding to the grille and remove the moulding.
- Undo the nuts holding the badge to the grille and take off the badge.

Refitting

- Reassemble in the reverse order and remount the grille.

§ 15 2 5600

REMOVING AND REFITTING A RIGHT OR LEFT GUTTER

Proceed as follows:

Removal

- Unscrew the screws holding the gutter to the body and take it off.

Refitting

- If signs of seepage are noted, apply suitable strips of caulking compound. Reassemble the gutter in the reverse order.

REMOVING AND REFITTING THE FRONT BUMPER ASSEMBLY

Drive the car over the pit and *proceed as follows:*

Removing

- Working in the pit, detach the air duct, remove the four bolts securing the bumper to the wheelhouse panel side brackets, remove the bayonet couplings from the front bumper headlight cables.
- Pull away the two air intake grilles (fixed by pressure to the four teeth), remove the two bolts holding the bumper to the front brackets, and remove the bumper.

At the bench

- Unscrew the bolts securing the front lights and take them off the bumper. (To replace bulbs there is no need to remove the body of the light, just the front).

Refitting

- Refit in the reverse order, check that the clearance between bumper, grille and quarter panels is constant, and then tighten up nuts and bolts on the brackets.

§ 15 2 5900

REMOVING AND REFITTING THE REAR BUMPER

Fit covers 88083051 and *proceed as follows:*

Removal

- Raise the lid of the boot and take out the spare wheel.

- Unscrew bolts (1) and nuts (2) and take off the bumper.

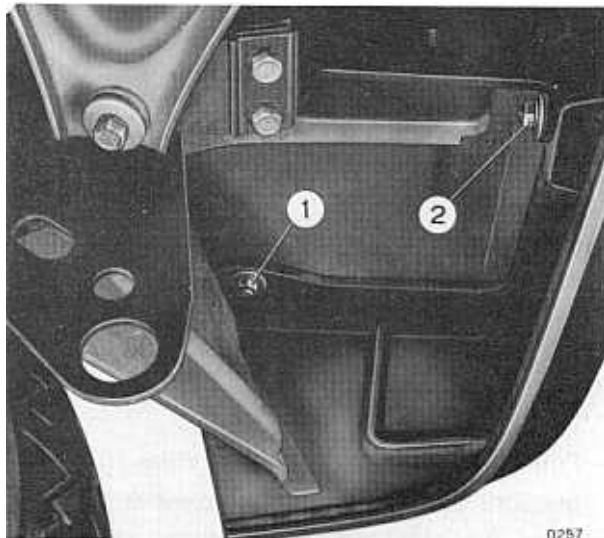

Fig. 15 2/31 - Right-hand rear bumper

Refitting

Reassemble in the reverse order.

§ 15 2 6200

RENEWAL OF REAR GRILLE

Fit covers 88083051 and *proceed as follows:*

Removal

- Remove the spare wheel and jack.
- Unscrew the bolts holding the radiator reservoir and shift it towards the engine.
- Disconnect the headlamp leads.
- Unscrew the nuts holding the grille and detach the grille.

At the bench

- Unscrew the nuts holding the headlamps and registration plate holder.

Refitting

Reassemble in the reverse order.

SUN ROOF

§ 15 2 7300

REMOVING AND REFITTING SIDE WING

Proceed as follows:

Removing

- Remove the engine bonnet as described at 15 2 2700, take out the spare wheel and, working from inside the engine compartment, unfasten the three nuts and two bolts securing the moulding to the quarter panel.
- Remove the two nuts (4) and (5) securing the grille (6) to the pillar and, working from within the engine compartment, unfasten the three nuts securing the wing to the wheelhouse panel and remove the wing.

Refitting

- Refit the wing to the panel and fasten nuts in bolts (1), (2), (3).

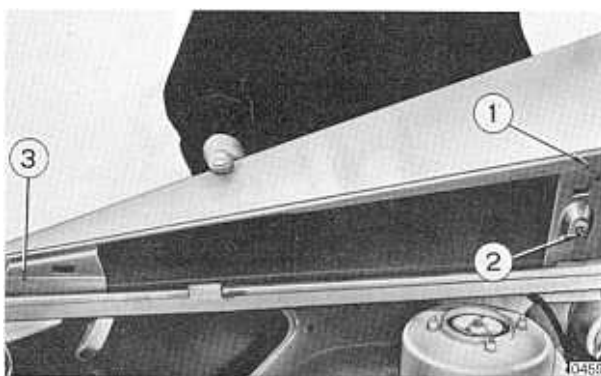

Fig. 15 2/32 - Refitting wing.

- Position the air outlet grille (6) on the pillar and fasten nuts in bolts (4) and (5).

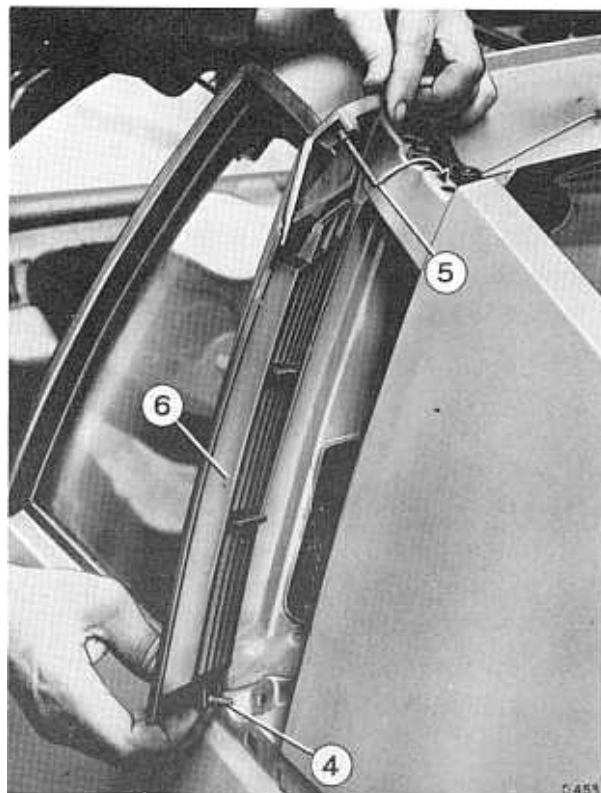

Fig. 15 2/33 - Refitting air outlet grille.

- Refit all the remaining parts in the reverse order to removal.

§ 15 2 8000

REMOVING AND REFITTING SOFT SUN ROOF

Removing

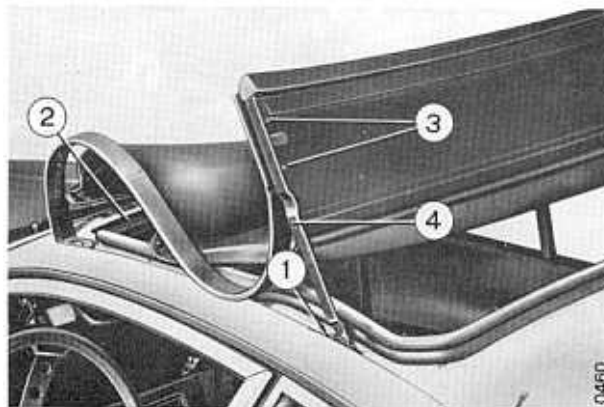

Fig. 15 2/34 - Removing sun roof.

- Open the sun roof, raise the weatherstrip corresponding to the two fixing bolts (1) and remove these; extract the sun roof from the

front crosspiece (2); remove the bolts (3) securing the stretcher (4) and then remove the complete sun roof.

Refitting

- Refit in the reverse order. When this operation is completed, make sure the roof is set correctly and check closing.

§ 15 2 8100

REMOVING AND REFITTING THE SOFT TOP OPENING CATCH

Fit covers 88083056 and *proceed as follows:*

Removal

Turn the handle (1) as shown by the arrow and raise the top.

Remove the handle (1) by turning it downwards and take off the flashing (2).

- Slacken nuts (1) and unscrew bolts (2) before taking off the catch (3) (see fig. 15 2/35).

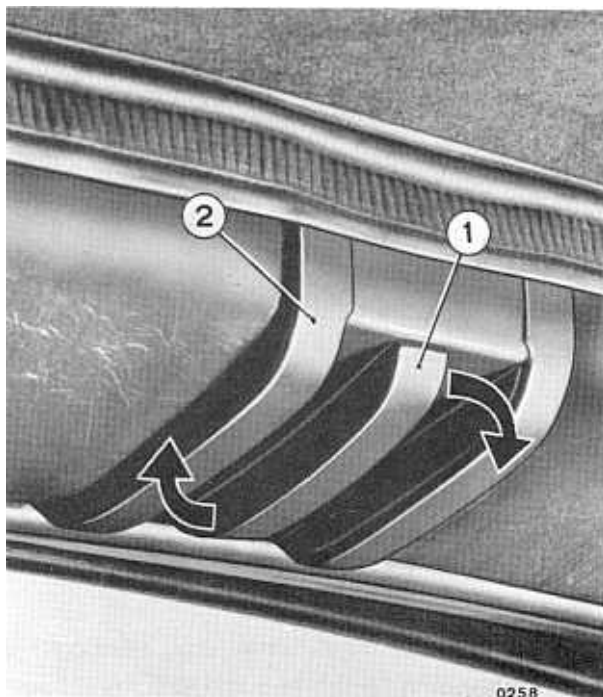

Fig. 15 2/35 - Soft top opening handle

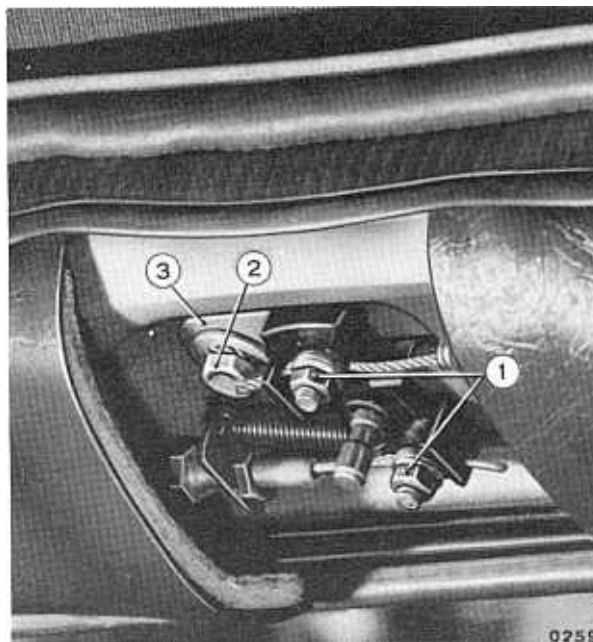

Fig. 15 2/36 - Soft top opening catch

- From the engine compartment, unscrew the nuts holding the stale air escape grilles and remove the grilles.
- Unscrew bolts (1) and remove the strikers (2) and their rods (see fig. 15 2/36).

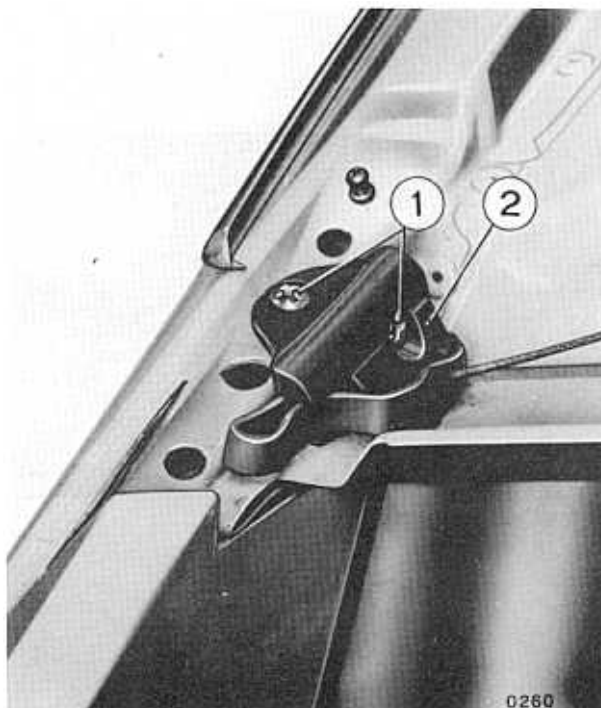

Fig. 15 2/37 - Soft top latching device

Refitting

- Reassemble in the reverse order and check that the catch works.

CHAPTER 2

BUMPERS AND MOULDINGS

§ 15 2 5700

REMOVING AND REFITTING FRONT BUMPER ASSEMBLY

Drive the car over the pit and *proceed as follows*:

Removing

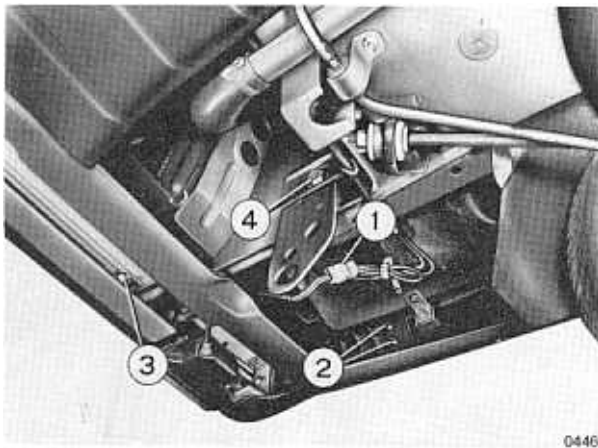

Fig. 15 2/1 - Removing bumper.

- Disconnect the electrical connections (1).
- Unfasten the nuts (2) and (3) and detach the bumper from the shock absorbers.
- Remove the headlights from the bumper.

Refitting

- Refit in the reverse order to removal, making sure that the bumper is correctly centred. Then tighten up the securing bolts.

§ 15 2 5740

REMOVING AND REFITTING A FRONT BUMPER SHOCK ABSORBER

Drive the car over the pit and *proceed as follows*:

Removing

- Remove the bumper as described at 15 2 5710.

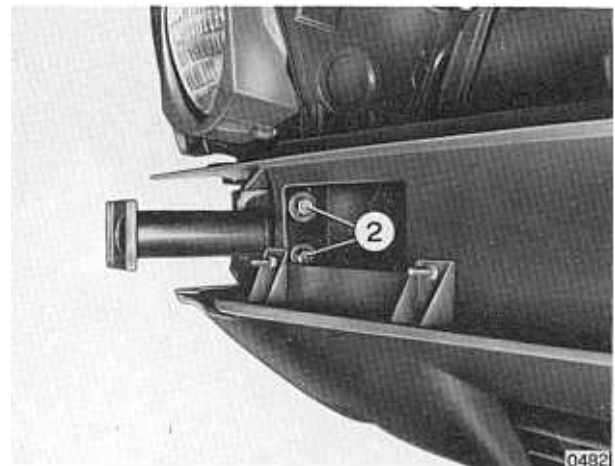

Fig. 15 2/2 - Removing bumper shock absorber.

- Unfasten the bolt (4) (fig. 15 2/1).
- Remove the bolts (2) and withdraw the shock absorber from its seating.

Refitting

- Refit in the reverse order, completing the operation by refitting and adjusting the front bumper as described at 15 2 5710.

§ 15 2 5900

REMOVING AND REFITTING REAR BUMPER

Drive the car over the pit and *proceed as follows*:

Removing

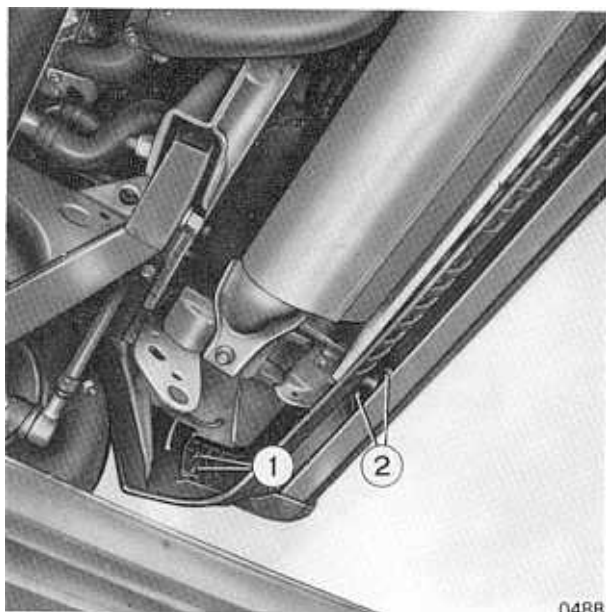

Fig. 15 2/3 - Removing bumper

- Unfasten the nuts (1 and 2) and detach the bumper from the shock absorbers.

Refitting

- Refit in the reverse order, checking that the bumper is correctly centred, then tighten up the securing bolts.

§ 15 2 5940

REMOVING AND REFITTING REAR BUMPER
SHOCK ABSORBERS

Drive the car over the pit and *proceed as follows*:

Removing:

- Remove the bumper as described at 15 2 5910.

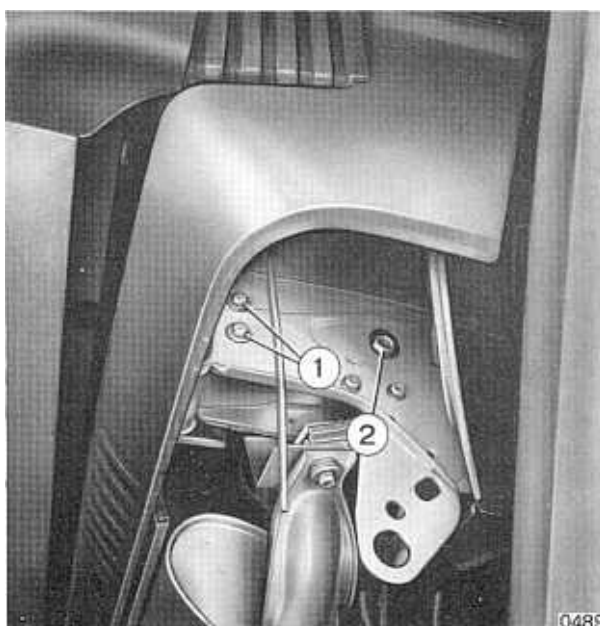

Fig. 15 2/4 - Removing bumper shock absorber.

- Unfasten the bolts (1) and (2) and withdraw the shock absorber from its seating.

Refitting

- Refit in reverse order to removal, completing the operation by refitting and adjusting the rear bumper as described at 15 2 5900.

BASIC MODEL

The instructions and operations refer to the tests of units relevant to all car models.

TESTS GROUP CONTENTS

CHAPTER 4

Engine

§ 16 4 0100	Spark plugs bench test	page 16 4/1	
§ 16 4 0400	Distributor performance and plug lead insulation bench test	" 16 4/1	
	Do. for U.S.A. cars	" 16 4/1	Variant U.S.A.
§ 16 4 0700	Ignition coil bench test	" 16 4/3	

Introduction to carburettor test

	Hydraulic checks	16 4/4	
	Air leak checks	16 4/6	
§ 16 4 1150	Fuel level check on the Weber DATR 200 carburettor	16 4/9	
§ 16 4 1700	Bench testing the Weber 34 DATR carburettor	16 4/10	
§ 16 4 2500	Jet check on the Weber 34 DATR carburettor	16 4/3	
§ 16 4 4200	Cylinder head tightness test	16 4/15	

Suspensions

§ 16 4 5100	Shock absorber bench test	16 4/17	
-------------	-------------------------------------	---------	--

Brakes

§ 16 4 5500	Bench testing the hydraulic brakes master cylinder	16 4/19	
-------------	--	---------	--

Electric system

§ 16 4 6400	Testing the starter motor on the test bench	16 4/21	
-------------	---	---------	--

CHAPTER 4

ENGINE

§ 16 4 0100

SPARK PLUGS BENCH TEST

Proceed as follows:

- Clean the outside of the plugs and then sand them with machine 88075024.
- Check that the gap between the electrodes is the correct value.
- Lock the plug to be tested on tester 88075014.
- Adjust the gap between the points to 15 mm, operate the tester compressor, connect the high-tension lead to the plug and depress the push-button to supply current to the plug.
- Gradually increase the pressure inside the tester chamber. Check that the plug is sparking properly through the inspection mirror. A plug should be considered defective when there is a spark between the points at a pressure of less than 5.88 bar (6 Kg/cm²).

Note: this test gives only an approximate idea of a plug's performance, since it does not reproduce the actual conditions under which it has to work on the engine.

TOOLS REQUIRED

- 88075024 Sanding machine
- 88075014 Spark plug tester

§ 16 4 0400

DISTRIBUTOR PERFORMANCE AND PLUG LEAD INSULATION BENCH TEST

Condenser performance check

- Disconnect the condenser from the distributor

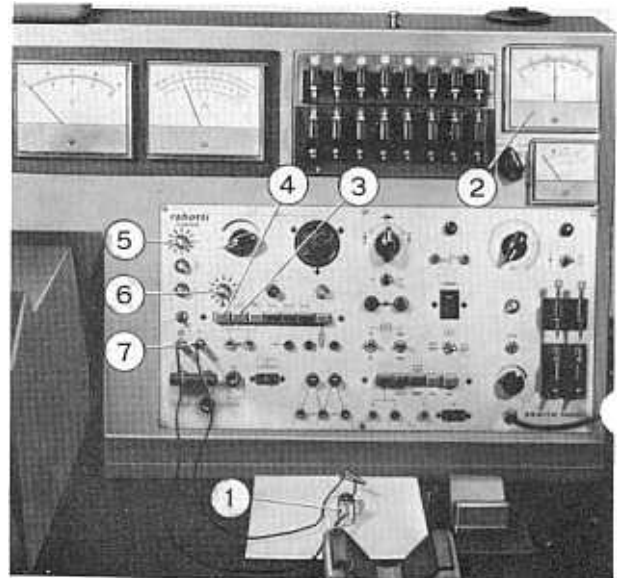

Fig. 16 4/1 - Condenser performance check

- Connect the condenser terminals (1) to the test sockets (7).
- Turn the switch to "Mains" and check that lamp (5) comes on.
- Depress condenser insulation testing button (4). If the insulation is perfect, bulb (6) will flash once only; if it flashes no more than 30 times per minute, the insulation is still satisfactory. If this figure is exceeded, the condenser must be changed.
- If no flash occurs at all or if the bulb stays on, the condenser is broken or short-circuiting and must be changed.
- If the insulation is perfect or satisfactory, depress button (3) and read the condenser capacity value shown on meter (2).

Distributor automatic advance curve check

Note: these instructions refer to test benches fitted with a protractor disc and a strobe device to display the breaker dwell angle.

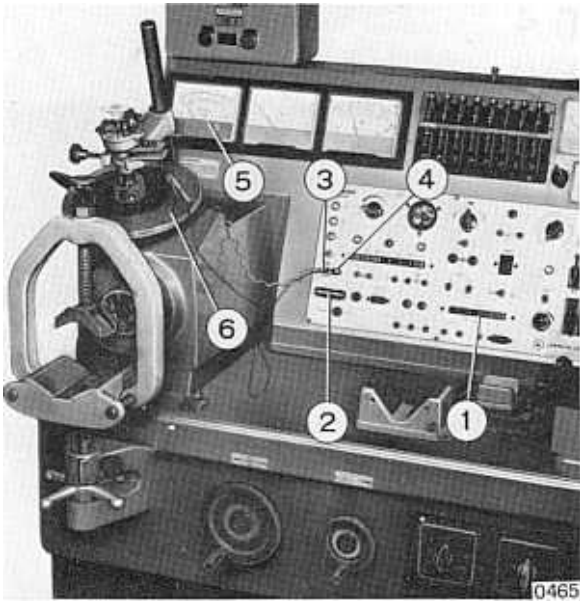

Fig. 16 4/2 - Distributor test.

- Remove the distributor cap and mount the distributor on electrical equipment test bench 88075016. Connect the drive shaft.
- Connect the distributor lead to socket (4) marked R and the strobe lead to socket (3). Select 12 V on the socket holder plate. Depress button (1) to insert the voltmeter and short-circuit the socket (2).
- Check which way the distributor turns and start the motor at its minimum speed in the same direction. Place the protractor disc (6) so that its zero coincides with one of the points where the index lights up.
- Check that the width of the sectors in which the index is alight is the same.
- Turn the speed control and gradually increase the revs, as shown by the rev counter (5). Note the shift of the luminous sectors of the disc with respect to the zero reference mark.
- Check that the automatic advance of the distributor agrees with the curve prescribed.
- Remove the connections at the end of the test.

Distributor performance check

- Fit the cap on the distributor. Fit an efficient ignition coil to the bench and connect the positive terminal to the bench 12 V outlet.
- Connect the ignition L.T. terminal to the distributor lead.
- Connect the distributor-to-coil H.T. wire and the distributor-to-plug H.T. wires to the test bench spark gaps. The distance between the electrodes should be 7-8 mm.
- Turn the distributor at different speeds by means of the speed control (1). Check that there is a regular stream of sparks across the points at these various speeds.
- Set the switch to the “coil test” position. Start the motor and run the end of the perfectly insulated wire along the outer surface of the lead under test. If the insulation of this lead is good, there will be no sparks across the second gap.

Lead insulation check

- Fit an efficient ignition coil to the bench and connect its positive terminal to a 12 V source and its L.T. terminal to the contact breaker socket.
- Turn the selector and depress the button to energise the 0.2. μ F. master condenser. Connect the coil H.T. terminal via the lead under test to one of the two spark gap H.T. sockets.
- The gap between the points should be 8-10 mm.
- Connect the other socket (spark gap at 2-3 mm) to a wire with perfect insulation.

EQUIPMENT REQUIRED

- 88075016 Electrical equipment test bench

§ 16 4 0700

IGNITION COIL BENCH TEST

Proceed as follows:

- Mount the coil on the bench and connect its positive terminal to the bench 12 V socket. Connect the other terminal to the breaker socket.
- Turn the selector and depress the button to energise the 0.2 μ F master condenser. Connect the coil H.T. terminal to the spark gap H.T. socket. The gap between the points should be 8-10 mm.
- Set the switch to the “coil test” position. Start the motor and check that the correct values are obtained when the coil is operating at various speeds.

INTRUCTION TO CARBURETTOR TEST HYDRAULIC CHECKS

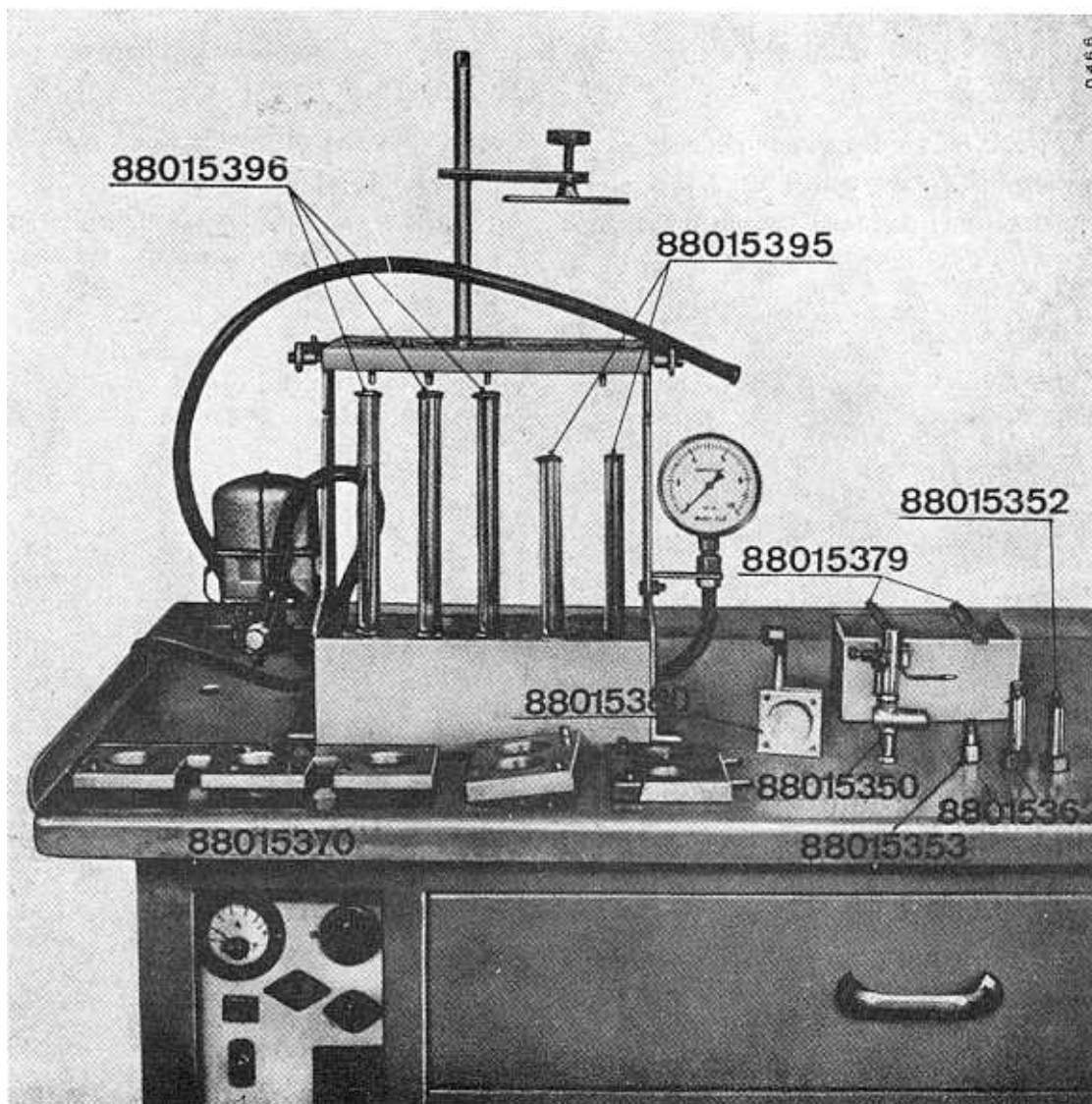

Fig. 16 4/3 - Hydraulic test equipment

The equipment shown in the photo can be used for the following hydraulic tests on all Lancia vehicles:

- a) Float chamber fuel level
- b) Needle valve tightness
- c) Acceleration fuel pump delivery

The equipment has fixture 88015370 as its main feature. This fixture is used to hold different types of carburettor in position as though they were on the engine, and supply them with test fluid at the same pressure as that of the fuel when the engine is running.

The fixture consist of an upper tip-up surface on which carburettors are mounted, either directly or by means of an adapter plate, and locked in position by a rapid-acting device.

The bottom of the fixture consists of a container, which is also used as the test fluid reservoir. Its lid is removable and acts as the support surface for the test tubes used to measure the delivery of the acceleration pumps.

A pressure gauge and an electric fuel pump similar to that usually employed on the Flavia injection model, though modified at the cut-out

pressure control valve, are mounted on the two uprights of the fixture respectively.

When the pump is working, a knurled knob below the suction union can be turned to obtain a pressure range of 2-6 mH₂O (0.2 – 0.6 Kg/cm²).

The fixture is also provided with four adapter plates and their gaskets. These are fitted between the top surface and the carburettor under test. Each adapter is marked with the reference data of the type of carburettor for which it has been designed.

The equipment also includes two 10 cc and three 25 cc glass test tubes. These are used to collect and measure the fluid delivered by the carburettor acceleration pump.

Fixture 88015370 must be mounted on a carburettor test bench by means of the holes in its base. Check that the top is perfectly horizontal with a spirit level and insert suitable spacers under the mounting holes as required. Turn the top through 90° and check that the surface is perfectly vertical.

1.5 - 2 litres of paraffin are poured into the reservoir. Petrol is not used for safety reasons. During the tests, check the cleanliness of the paraffin in the reservoir frequently to prevent dirt from entering the various parts of the carburettor.

The filter in the suction union should also be examined periodically and cleaned as required.

Rectifier-transformer 88070316

This transformer also forms part of equipment 88015370. It is used to step down the mains current to 12 V for supply to the fuel pump. Check the voltage changer and connect the transformer to the mains. Set the output voltage to 12 V and connect the fixture pump cable to its output terminals (red wire = positive; black wire = earth).

The pump is started and stopped by means of the transformer switch. The transformer is fitted with an automatic cut-on as a protection against short-circuits. After removing the cause of the overload, bring the transformer into operation

by depressing the red button alongside the ammeter.

Fuel level checking apparatus 88015350

This apparatus is used to obtain accurate measurements of the fuel level in the carburettor float chamber.

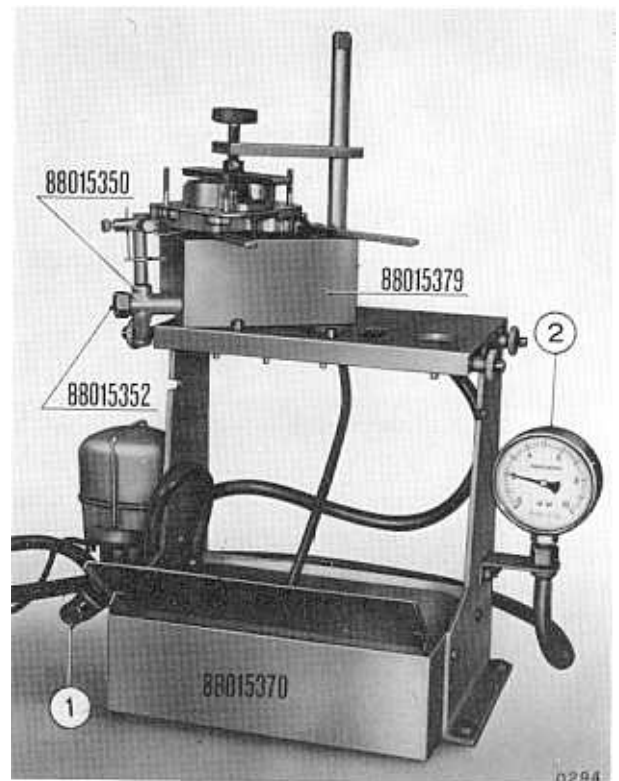

Fig. 16 4/4 - Fuel level checking apparatus for Weber carburetors.

It is connected to the carburettor body by means of banjo bolts 88015352 or 88015362, with or without connector 88015353. Seals are used with all these accessories.

When checking Weber carburettor float chamber fuel levels (Beta Montecarlo models), mount fixture 88015350 on tank 88015379 by means of bolt 88015352.

Remove the cover from the carburettor and mount it on the tank (see fig. 16 4/4). Operate the fixture pump. Owing to the principle governing the behaviour of fluids in communicating vessels, the liquid in the glass tube will rise to the same height as in the float chamber.

AIR LEAK CHECKS

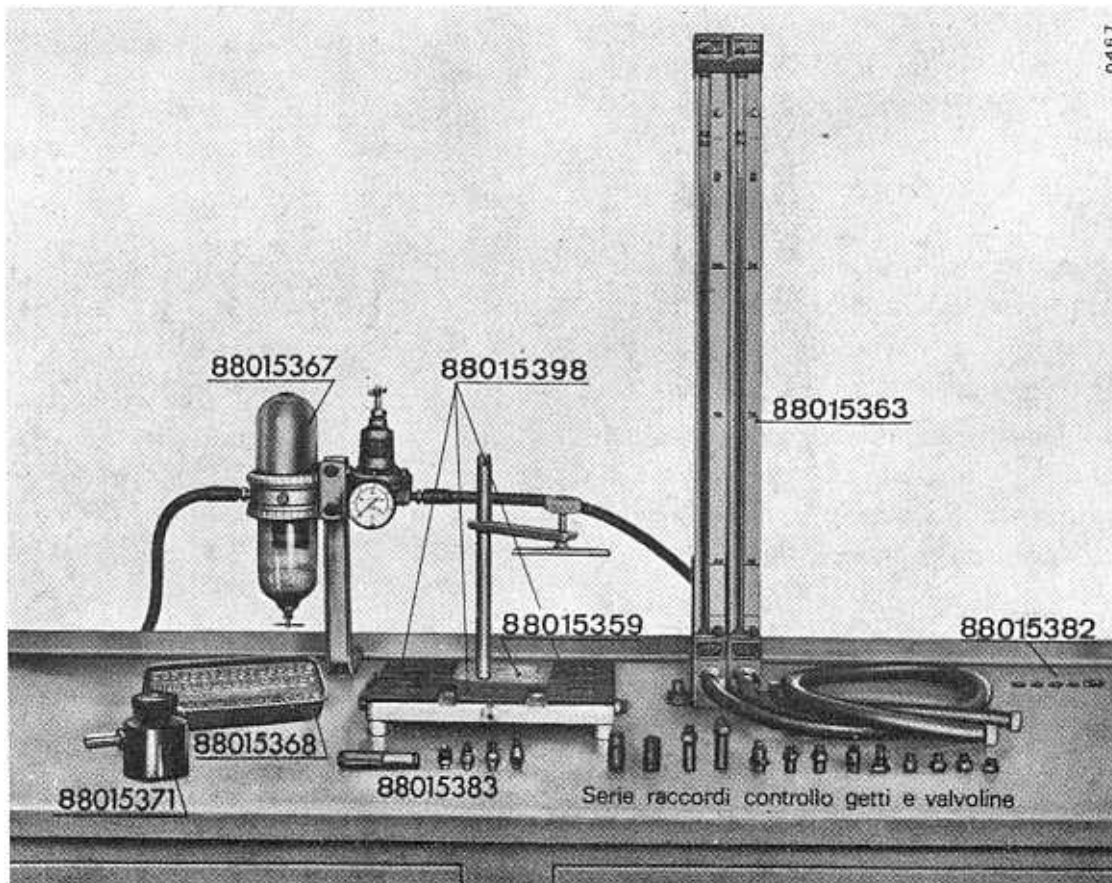

Fig. 16 4/5 - Pneumatic test equipment

The equipment shown in the photo can be used for the following pneumatic tests on all types of carburettor mounted on Lancia vehicles:

- a) Air leaks through the throttle valves at rest and their respective differences
- b) The maximum difference between the air leaks taking place through the valves in progressive movement.
- c) Acceleration pumps intake and delivery valve tightness.
- d) Delivery of jets.

The main feature of the equipment is a low-pressure Solex B2 microgauge (flowmeter 88015363). This instrument is very sensitive and gives accurate measurements of the air passing through an orifice, e.g. through the throttle

valves of a carburettor at rest. The gauge has two separate and independent scales, each fitted to an outlet hose as shown in fig. 16 4/5.

If one of these hoses is closed, it will be seen that the coloured fluid in the corresponding column falls right down to the lowest mark. This indicates that all the air reaching the gauge is escaping through the hose.

If the hose is partly closed (less than maximum escape), the level in the column will correspond to the leak caused by partial obstruction of the hose. The escape of air is measured by comparing known leaks through a master jet and the leaks to be determined. Equal levels in the columns correspond to an equal escape of air.

Calibrated jets, known as "head jets", are

fitted inside the flowmeter on the outlet hose connectors. These jets set the range of indirect measurements that can be obtained with the gauge.

The test set consists of 7 head jets:

One type A jet for the range 0 to 50/100;

Two type D jets for the range to 110/100;

Two type I jets for the range to 160/100;

Two type K jets for the range 90 to 200/100;

Two type N jets for the range 160 to 400/100.

The jet most suited to the leak value to be measured should be fitted, since this means that the more sensitive central portion of the scale can be utilised.

Warning: when changing a head jet, never unscrew the outlet hose connectors without first closing the air inlet tap on the pressure regulator filter.

Only one of the flowmeter scales is needed to check jet delivery, tightness or single leaks, whereas simultaneous checks on two leaks, as in the case of throttle valves of a twin-choke carburettor, require the use of both scales. In this case, of course, two head jets of the same type will be mounted and the difference in value between the two leaks can be read off immediately.

Calibrating the flowmeter

The apparatus is also supplied with four blank

scales for marking with leak values in the ranges most commonly employed (e.g. those set by jets I and K), so that immediate readings can be obtained.

Calibration is performed by fitting master jets of known delivery range within the range required to the outlet hoses, using the connectors mentioned below. The heights reached by the liquid in the scale columns are then marked with the delivery values for the jet in question.

It should be remembered, however, that the values corresponding to the marks on the scales may be subject to 3-4% error due to variations in the atmospheric pressure. When leaks from throttle valves or the like are being measured, of course, such a difference may be ignored. If, on the other hand, very accurate measurements are required, such as those for the delivery of a jet, it is always advisable to use a master jet, as described below.

Pressure regulator 88015367

A Solex pressure regulator filter is fitted between the air supply line and the flowmeter inlet pipe to ensure a supply of clean air at a constant pressure. A pressure range of 2-3 Kg/cm² can be obtained by turning the knob and observing the readings on the pressure gauge.

The regulator is fitted with a side tap to shut the air inlet and a bottom tap to drain off sludge and moisture.

GETTO DI TESTA	CAMPO DI MISURA	PRESSIONE DEL REGOLATORE
Tipo		Kg/cm ²
A		2
D		2
I		2,5
K		2,5
N		3

Fixture 88015359

This fixture is used to hold carburettors when checking the escape of air through their throttle valves.

It consists of a plate with various centre pieces of different diameter and centre-to-centre distances, according to the type of carburettor to be tested. The carburettor under test is mounted on its centre piece with its flanges resting correctly on the special gasket. It is then locked from above by screwing down the locking shoe without forcing.

Note: in the case of Weber carburettors from Beta vehicles, the 7th modification of fixture 88015359 is used (see fig. 16 4/7). This enables the leak test to be carried out on the throttle valves of one choke at a time.

Warning: the gasket must always be fitted with the smooth side facing upwards, i.e. touching the carburettor flanges. Care should also be taken to see that carburettors under test are completely free of petrol or paraffin to prevent damage to the gasket.

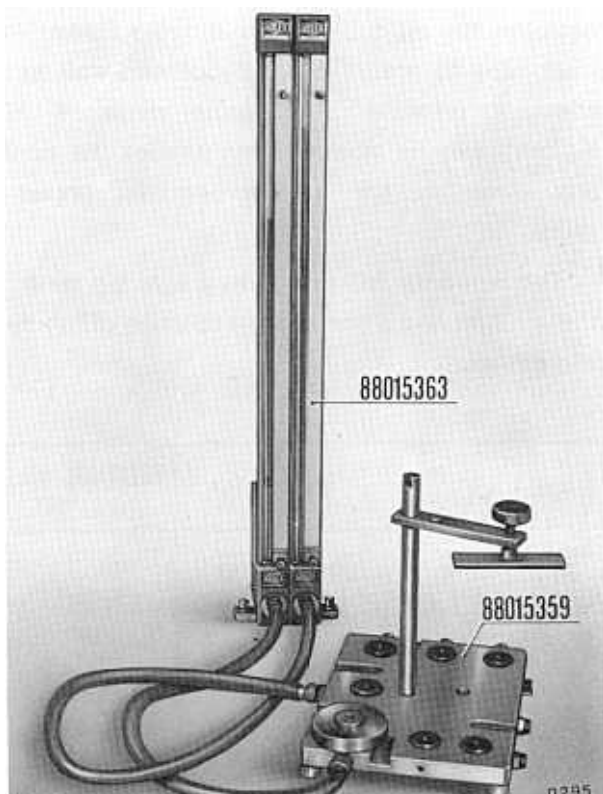

Fig. 16 4/6 - Fixture 88015359 (7th Mod.) For Air Leak Tests on Carburettors.

To detect throttle leaks, plug all other places through which leaks might occur. The measures to be adopted are described for each test.

Mount the carburettor as previously explained. Move (or try to move) it slightly and check that no changes occur in the leak values shown on the flowmeter. If changes are noted, unlock, reposition and relock the carburettor.

Set of master jets 88015368

This set consist of 69 jets whose delivery values accurately cover the ranges normally found in carburettors:

15 slow-running jets with values from 35/100 to 70/100;

33 main jets with values from 50/100 to 200/100;

21 air corrector jets with values from 100/100 to 300/100

Support 88015371

When used in conjunction with the connectors in set 88015393, this fixture enables the delivery of any carburettor jet to be accurately determined by comparison with the known delivery value of its corresponding master jet.

One of the flowmeter hoses is fitted to the chromium-plated inlet pipe of the support. A jet-holder suitable for the type under test is then screwed to the threaded top seating.

The knurled cap of the support can be unscrewed to fit various types of jet inside the support, so that air from the flowmeter is passed through them.

Set of adapters 88015383

In addition to the delivery and calibrating tests already described, these adapters are also used in checking the acceleration pump valves.

Each adapter has a knurled handle that is screwed into one of the rapid-fit connectors mentioned when dealing with fixture 88015359. Various types of ends can be mounted on the other side of the handle. Each end is provided

with a suitable rubber head and will be selected in accordance with the particular check to be carried out.

Set of plugs 88015382

Whenever one of the passages of a carburettor has to be plugged for testing purposes, a rubber plug of suitable diameter is chosen from this set.

§ 16 4 1150

**FUEL LEVEL CHECK ON THE WEBER DATR
200 CARBURETTOR**

Proceed as follows:

- Use bolt 88015352 to mount the test apparatus 88015350 on the tank 88015379.

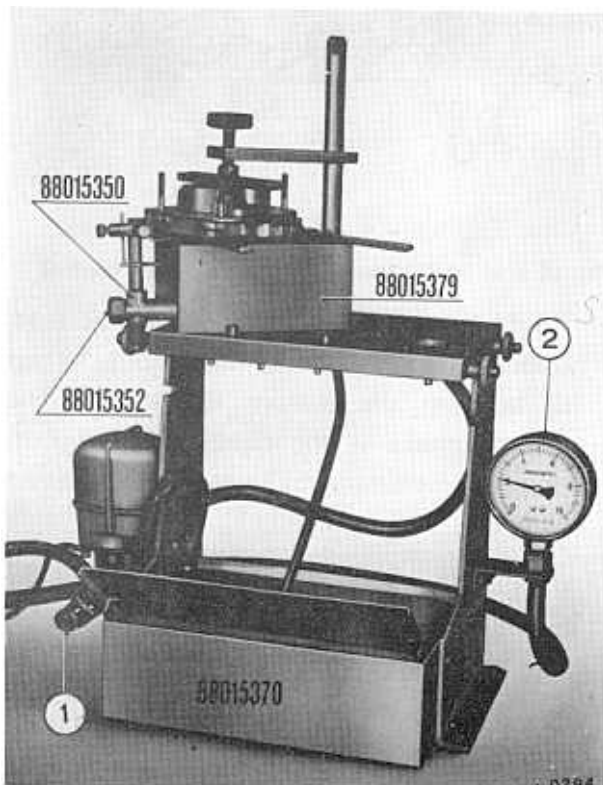

Fig. 16 4/7 - Checking the fuel level

- Place the tank on the top surface of fixture 88015370 and use the two rods to mount the carburettor cover on the tank. Make sure that the float is free to move up and down without touching the inside walls of the tank. Lock the assembly in place by means of the

quick-locking device supplied as part of fixture 88015370.

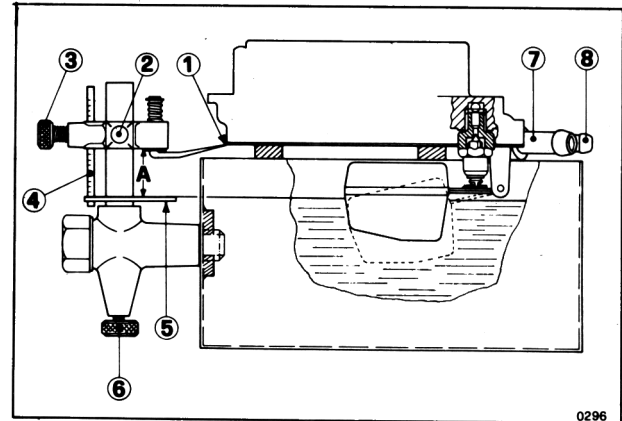

Fig. 16 4/8 - Location of test apparatus 88015350

- Connect the fixture feed pipe to the fuel inlet (7) on the carburettor cover, and a length of hose between the drain-off outlet and the tank.
- Slacken bolt (2) holding the apparatus pointer and set the pointer as shown at (1).
- Operate the fixture delivery pump and use knob 1 (see fig. 16 4/7) to regulate the pressure to the value required for the test.
- Slacken knob (6) until a small trickle is obtained. This represents the consumption of fuel that would take place if the engine was idling.
- Check that the test fluid is steady inside the transparent pipe, slacken screw (3) holding the millimetric ruler and set the reference plate (5) in line with the centre of the meniscus in the pipe. Tighten the screw (3).
- Check that gap "A" is of the correct width. If not, change the float or, if the discrepancy is not large, remove the needle valve and fit it with a thicker or thinner seal, depending on whether the level has to be lowered or raised.
- On completion, repeat the level test.

Checking the needle valve seal

- Operate knob 1 (see fig. 16 4/7) to bring the feed pressure to the maximum value indicated. Check that the level does not tend to rise, even after a time, i.e. that the needle

valve is properly sealed. If the level does rise, renew the valve and repeat the test.

- Stop the delivery pump. Remove the hoses from the cover and the latter from the tank.

TOOLS ETC REQUIRED

- 88015352 - Bolt
- 88015379 - Tank for fuel level test
- 88015370 - Fixture for hydraulic tests
- 88015350 - Apparatus for fuel level test

§ 16 4 1700

BENCH TESTING THE WEBER 34 DATR CARBURETTOR

Proceed as follows:

- Clean the carburettor thoroughly with paraffin or trichloroethylene and blow dry with compressed air.

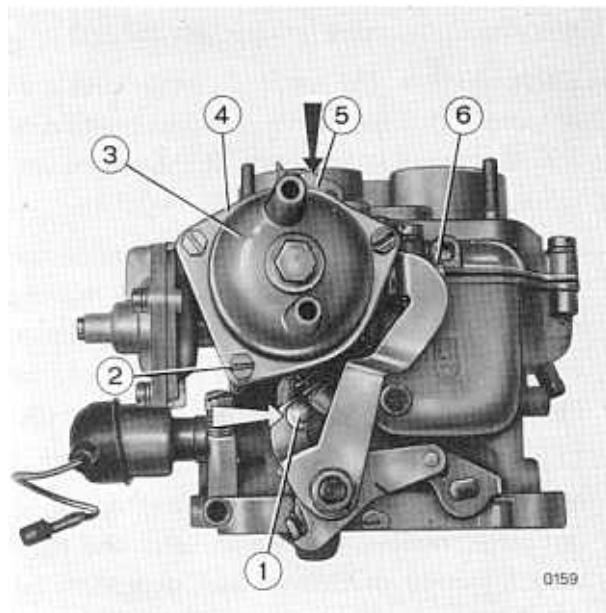

Fig. 16 4/9 - Weber 34 DATR 200 carburettor seen from the rich mixture control and choke cut-off side

- Check that the choke throttle is not inserted and that the rich mixture control throttle close automatically when the main throttles control lever (1) is operated. If this does not

take place, unscrew bolts (2), take off the spring housing (3) together with its snap ring (4) and renew the broken or miscalibrated thermostatic spring.

Note: to release the rich mixture control, push lever (5) right down and at the same time disengage screw (6) from the control by means of the throttles control lever (1). Then release lever (1) and lever (5) in that order.

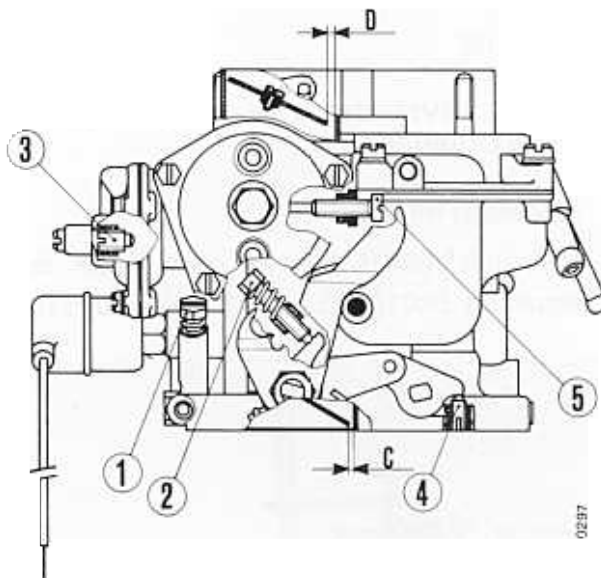

Fig. 16 4/10 - Adjustment of the rich mixture control

- Use feeler gauge 88095770 to check that, when the rich mixture control is on, the gap 'C' between the bottom throttle and the primary choke is the right width. If not, adjust as necessary by means of adjusting screw (2).

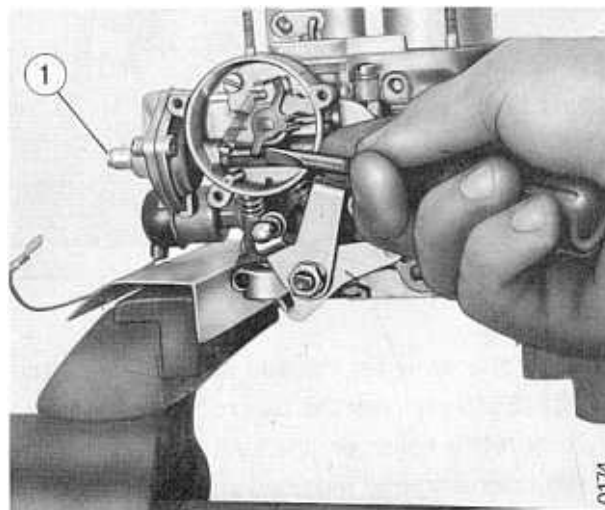

Fig. 16 4/11 - Checking the opening of the rich mixture control throttle when operated by the cut-off device

- With the carburettor in a lead-jawed vice and the rich mixture control on, use a screwdriver to operate the cut-off device and check that the gap 'D' between the top throttle and the primary choke is the right width. If not, adjust as necessary by means of screw (3) (see fig. 16 4/11), after loosening screw (1).

Checking the throttles for leaks

- Tighten the slow-running setting screw (1) right down, though without forcing it.

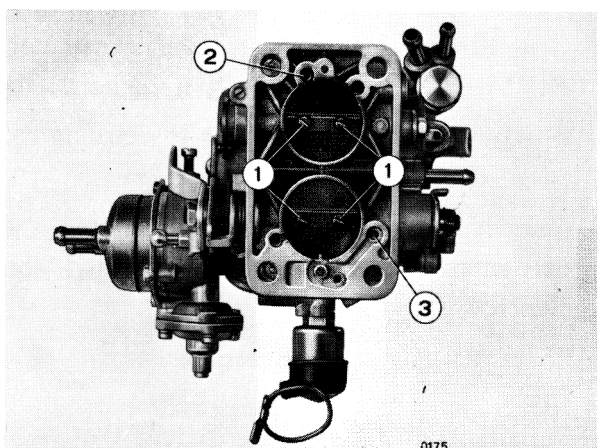

Fig. 16 4/12 - Carburettor (bottom view)

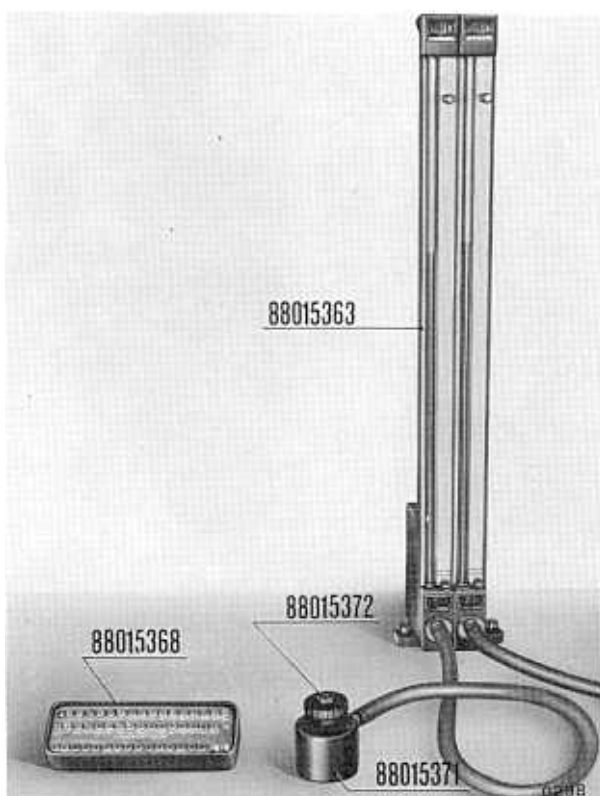

Fig. 16 4/13 - Support 88015371 and flowmeter 88015363

- Block ports (2) and (3) with putty.
- Mount an "N" and an "I" head jet on the flowmeter 88015363. Connect the "N" jet tube to support 88015371. Screw the support to connector 88015372, complete with a master air corrector jet whose delivery corresponds to the correct escape value for the primary valve.
- Feed air at the correct pressure to the flowmeter and mark the level reached by the liquid in the column on the scale.
- Disconnect the "N" jet tube and connect the "I" tube.
- Take off connector 88015372 and replace it with connector 88015373. Screw on a master main jet whose delivery corresponds to the correct escape value for the secondary valve.
- Read off the value reached by the liquid on the other scale and disconnect the flowmeter tube from the support.

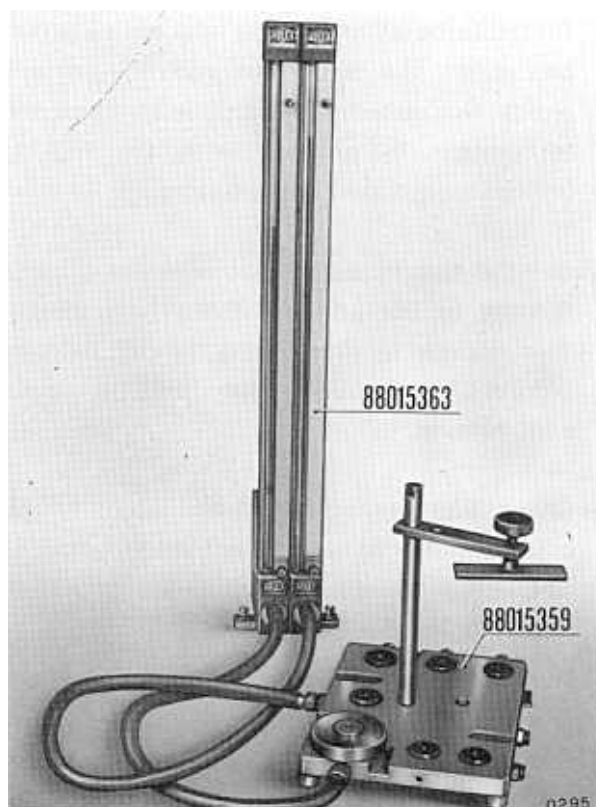

Fig. 16 4/14 - Fixture 88015359 (7th modification)

- Connect the "N" jet tube to the locating inlet of fixture 88015359 (7th modification)

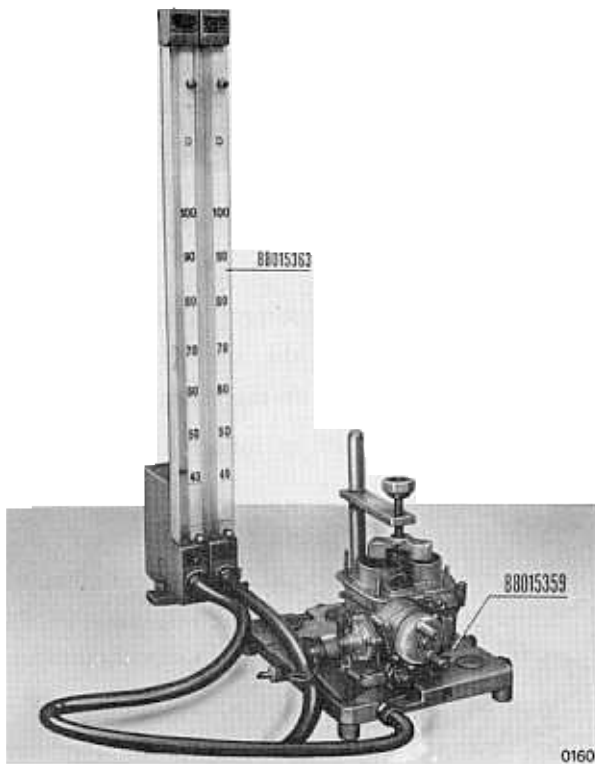

Fig. 16 4/15 - Carburettor in position on fixture 88015359

Fit the carburettor locating inlet with a gasket and mount the carburettor with the primary choke well attached to this inlet. Lock the carburettor in position with the locking device incorporated in the fixture.

Note: the test is carried out with the bottom throttle of the primary choke fully closed. This is done by disengaging the rich mixture control and working the throttle valves control lever.

Check that the height of the liquid in the column is the same as that already noted. If not, adjust as required by means of setting screw (2) (see fig. 16 4/10).

- With the choke off, work the throttles control lever up and down a few times and check that the height of the liquid in the columns does not change appreciably when the throttles are at rest.

Also check that no changes in the escape of air occur when an attempt is made to shift the

throttle spindle by hand.

- Mount the secondary choke on the inlet and relock the carburettor in position. Connect the "I" jet tube instead of the "N" tube on the locating inlet.
- Check that the height of the liquid in the column is the same as that already noted. If not, adjust as necessary by means of setting screw (4) (see fig. 16 4/10).
- Check the play of the secondary choke throttle spindle as already described.
- Dismount the carburettor from the fixture. Close the air supply to the flowmeter. Remove all traces of putty from the ports.
- Dismount the fuel filter from the carburettor cover, clean and remount.
- Remove the carburettor cover. Unscrew the rich mixture control mounting screws and detach this part from the cover.
- Check the fuel level as described at para 16 4 1150.

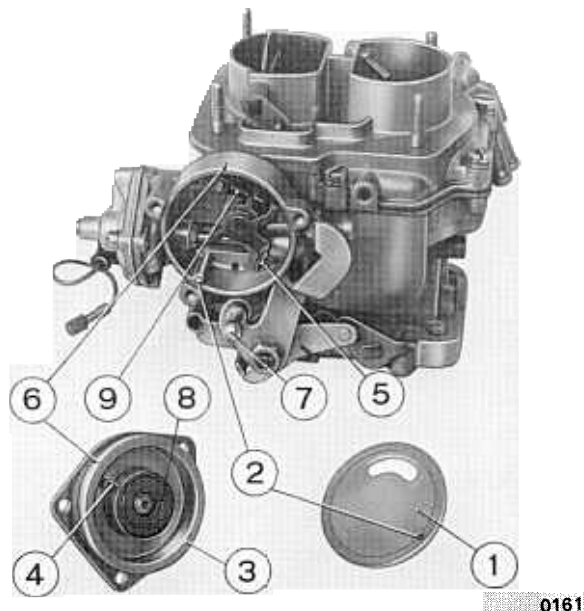

Fig. 16 4/16 - Rich mixture control mechanism

- Mount gasket (1) in accordance with reference marks (2). Mount the spring (3) in such a way that the thermostatic spring (4) enters the yoke (5) and the rich mixture control.

- Then turn the housing anticlockwise till reference marks (6) meet, and lock it by means of its mounting screws.
- Remount the carburettor cover.
- Check that the rich mixture control valve closes completely when control (7) is operated. If the valve is off centre, slacken the screws holding it to the spindle, centre it with respect to the choke and then retighten the screws.

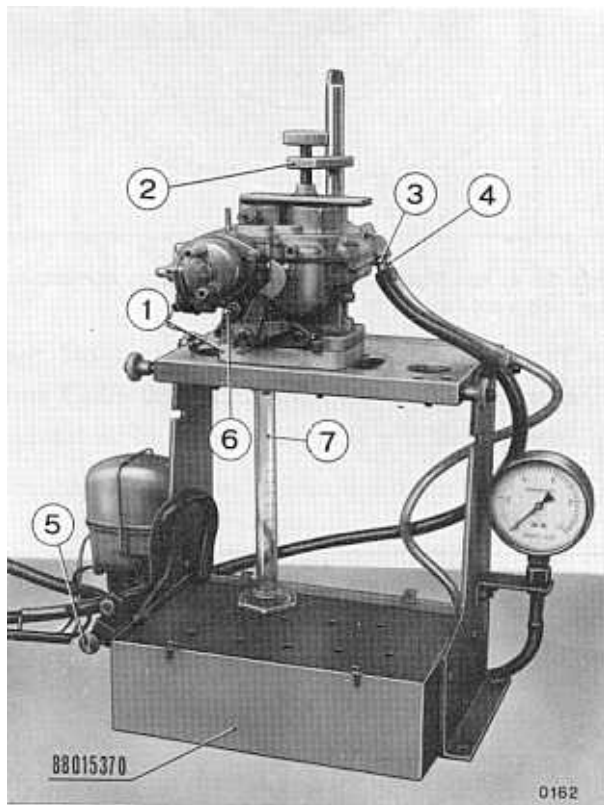

Fig. 16 4/17 - Checking the delivery of the acceleration pump

- Place the carburettor on plate (1) and gaskets and attach it to fixture 88015370. Lock it in this position with the rapid-locking device (2).
- Connect a length of hose to the carburettor leak-off outlet and allow the other end to drain into the fixture tank.
- Operate the fixture feed pump and use knob (5) to regulate the delivery pressure to the correct value.
- Work the throttles control lever (6) up and

down until the test fluid starts to drip from the bottom spout of the tilting plate corresponding to the primary choke.

- Place a 20 cc test tube (7) on the bottom shelf of the fixture under this spout. Work lever (6) slowly through its full travel, forwards and backwards. Ten pumping actions of this kind should fill the test tube with the correct amount of fluid.
- Turn off the fixture feed pump. Remove the hoses. Take off the carburettor and blow it dry with compressed air.

TOOLS REQUIRED

- 88095770 - Feeler gauge
- 88015363 - Flowmeter
- 88015371 - Support
- 88013572 - Connector
- 88013573 - Connector
- 88015359 - Fixture for checking throttle air leaks
- 88015370 - Fixture for hydraulic tests on carburettors
- 88015350 - Fixture for checking fuel level

§ 16 4 2500

JET CHECK ON THE WEBER 34 DATR 200 CARBURETTOR

Proceed as follows:

- Take off the carburettor cover

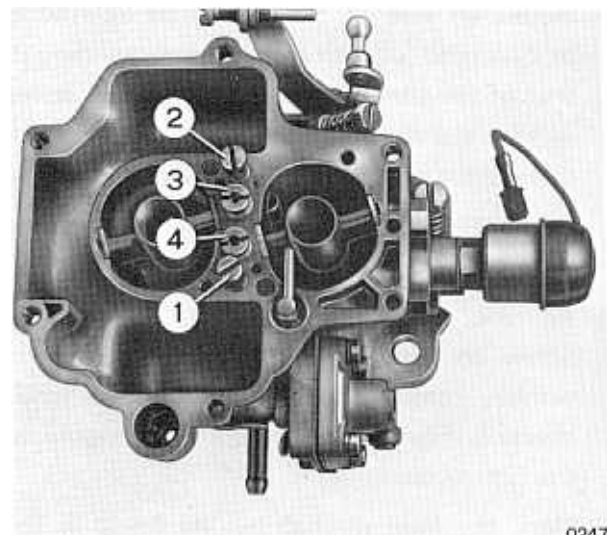

Fig. 16 4/18 - Carburettor with the cover removed

- Unscrew and remove jets (1) and (2) and the diffusers, complete with the air corrector jets (3) and (4).
- Wash the jets to be tested with trichloroethylene.
- Select master jets with the corresponding delivery ratings (slow running jets, main jets, air corrector jets) from the master set 88015368.

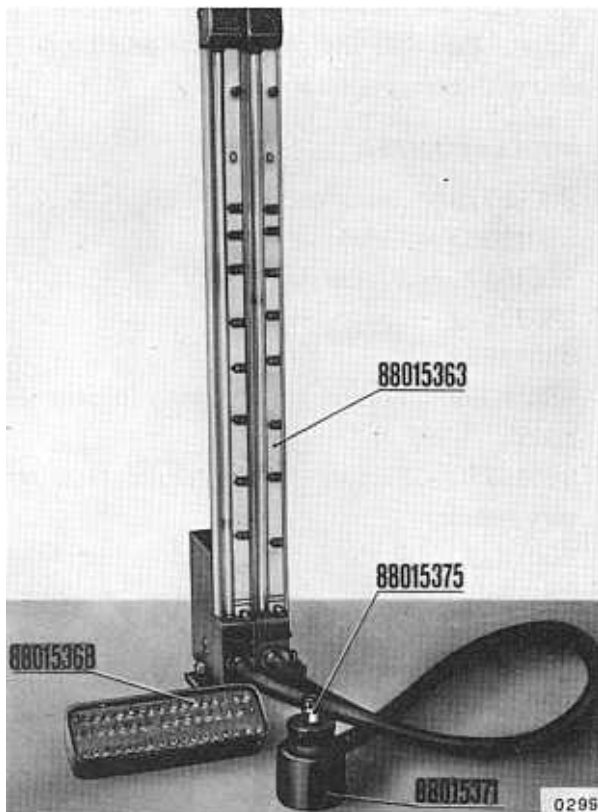

Fig. 16 4/19 - Flowmeter

- Mount on one of the flowmeter 88015363 pipes a head jet with a range corresponding to that of the slow running jets. Head jet scales will be found in Group 16 Tests, under the description of the way the flowmeter works.
- Connect the other end of the pipe to the support 88015371.
- Fit the support to connector 88015375. Screw on a master slow running jet whose delivery corresponds to that of the jet to be checked. Feed air at the correct pressure to the flowmeter.
- Mark the level reached by the liquid in the column by shifting the plastic cursor on the

pipe until its centre line is over the level observed.

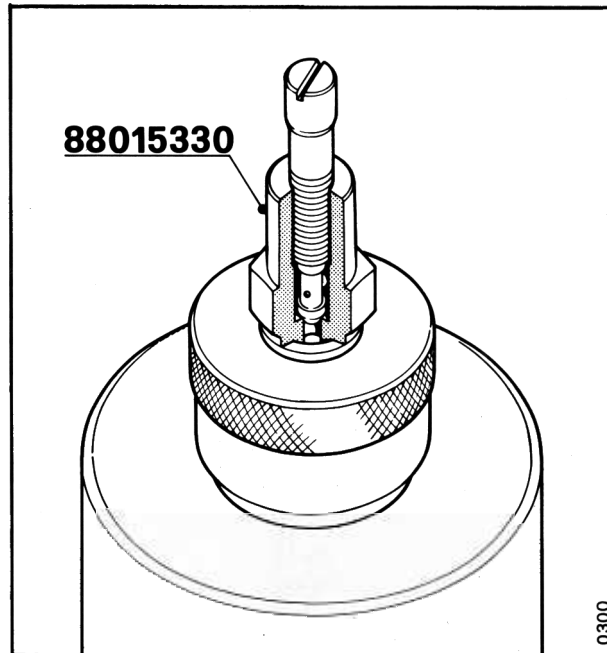

Fig. 16 4/20 - Slow running jet mounted on corrector for delivery test.

- Take the master jet and connector off the support. Screw on connector 88015330 and then mount the slow running jet to be tested.
- The level of the liquid in the column should

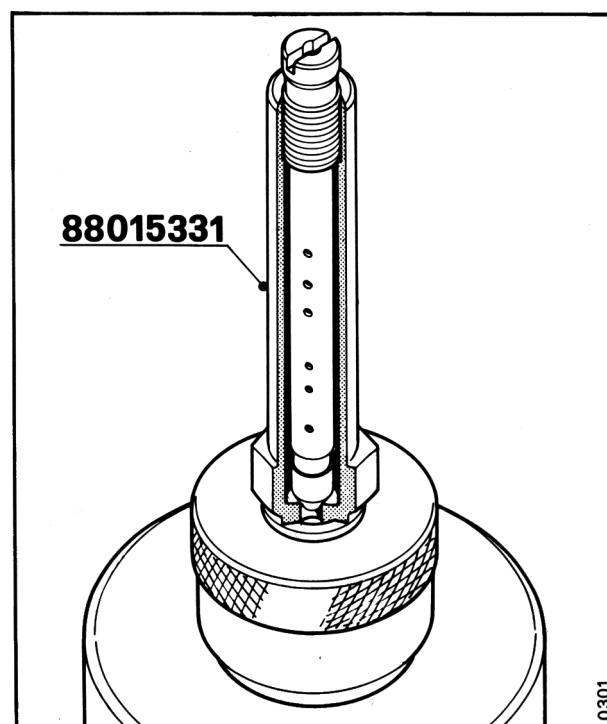

Fig. 16 4/21 - Main jet mounted on connector for delivery test.

rise to the same position as before. A higher or lower level will correspond to a greater or smaller delivery. A discrepancy that does not go beyond the bottom or top part of the cursor centre line will be acceptable.

- Repeat the operation for the other slow running jet.
- Adopt the same procedure for the main jets, using a suitable master jet mounted on connector 88015373. The jet under test, complete with diffuser and main air corrector jet, must be mounted on connector 88015331.

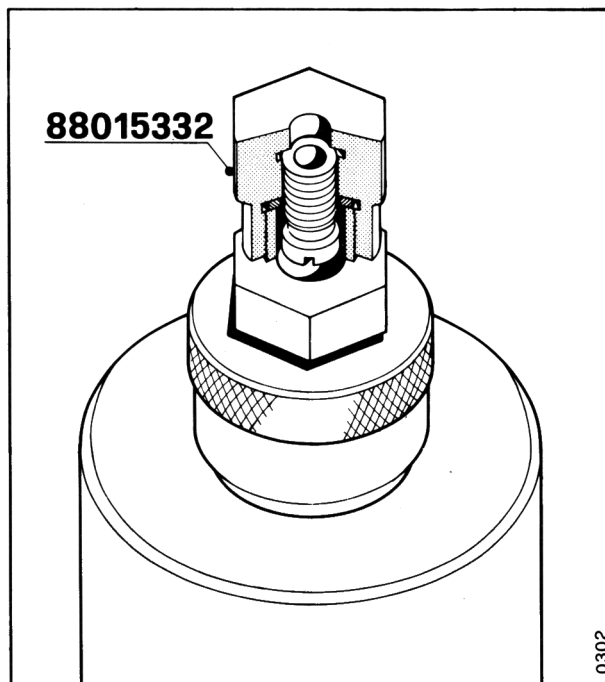

Fig. 16 4/22 - Main air corrector jet mounted on connector for delivery test

- Remove the main air corrector jets from the diffusers and test their delivery, using a suitable master jet on connector 88015372, and connector 88015322 for the jets under test.

Note: the delivery rating of the slow running air corrector jets is machined on the carburettor body. It can be checked with the aid of adapter 88015383 and end "C". Comparison is then made with a suitable master jet with the same delivery value.

- Clean the float chamber and jet seatings

thoroughly.

- Reassemble the jets and carburettor cover.

TOOLS REQUIRED

- 88015368 - Set of master jets
- 88015363 - Flowmeter
- 88015371 - Support
- 88015375
- 88015330
- 88015373 - Connectors
- 88015331
- 88015372
- 88015332
- 88015383 - Adapter

§ 16 4 4200

CYLINDER HEAD TIGHTNESS TEST

Disassemble as described at para. 01 4 2700 and *proceed as follows:*

- Remove the carburettor from the inlet manifold. Fit a new gasket to the manifold and mount it on the cylinder head.

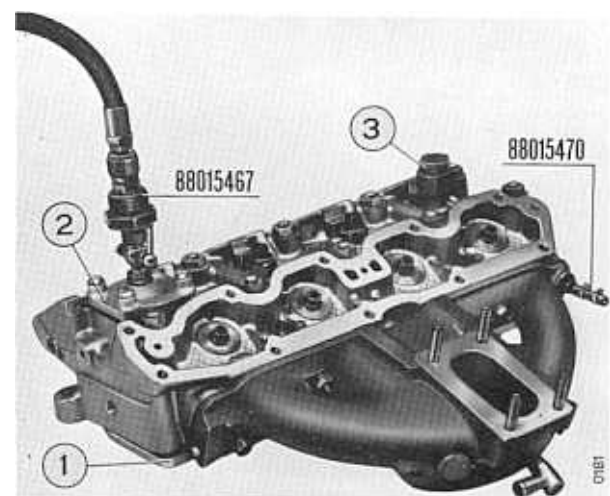

Fig. 16 4/23 - Cylinder head fitted with tightness test equipment

- Fit plate (1) and its gasket on the head and lock with the bolts forming part of the equipment 88015466.

- Mount plate (2), complete with tap and

gasket, on the water outlet of the cylinder head

- Fit connector 88015467 tightly on the tap and connect it to the compressed air hose.
- Fit plug (3) on the water outlet to the heater.
- Fit plug 88015470 on the water outlet to the automatic rich mixture control.
- Supply air at $4.90 \div 5.88$ bar ($5-6 \text{ Kg/cm}^2$) to the head in a tank with water at 90° C (or more). When the head is the same temperature as the water, check that there are no leaks from the equipment gasket or the inlet manifold gasket.
- Lastly, check that there are no bubbles from the head or the manifold. If these are seen, the part where they are located must be renewed.

- It should, however, be borne in mind that leaks from the manifold may be due to a poor fit on the part of the manifold plugs.
- On completion, remove the equipment from the head and blow the latter dry with compressed air. Take the manifold off the head.

TOOLS REQUIRED

- 88015466 - Equipment for cylinder head tightness test
- 88015467 - Connector
- 88015470 - Screw plug

SUSPENSIONS

§ 16 4 5100

SHOCK ABSORBER BENCH TEST

Proceed as follows:

Fig. 16 4/24 - Shock absorber mounted on testing machine 88036401

- Check that the reference mark stamped on disc (8) corresponding to the type of shock absorber under test is in line with the mark stamped on the top pad (2). To position the disc, slacken the bolts (3) holding the two

locking pads. Retighten these bolts when the correct position has been selected.

- Check that the lower arm (4) is mounted on the centre of disc (1). The centre hole and the two holes at the end of the arm are used for this purpose.
- Check the eccentricity of the crankpin on the slot (6) of the flywheel that drives the slide. The value should be 50 mm, which corresponds to a slide stroke of 100 mm.
- Adjustments are made by simply shifting the crankpin on the flywheel.
- Fit pins 88035421 on the arms (7) and (4) of the machine. Set the upper arm (7) mounting pin in the hole corresponding to a length of 200 mm.
- Mount the (front or rear) shock absorber on the arms as shown in the photo.
- To check the effective travel (100 mm) of the shock absorber, adjust the slide as follows:
- Zero the stroke meter (8) pointer.
- Allow the machine to run for a few moments at the testing speed.
- Stop the machine and check how far the pointer has moved. This shift shows the length of stroke lost due to settlement of the top eye of the shock absorber under load.
- Now the actual travel of the absorber can be determined by subtracting this value from the 100 mm stroke of the slide.

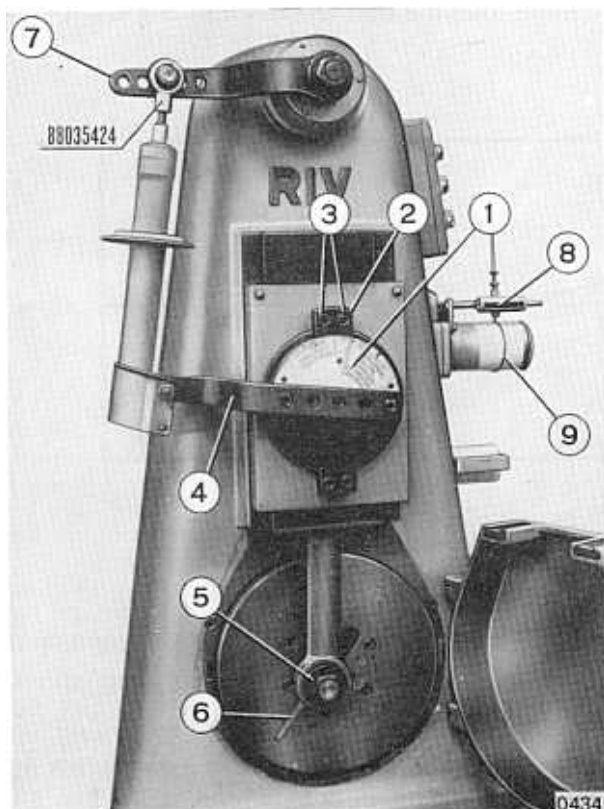
Example:

$C_r = C_s - C_p$, where:

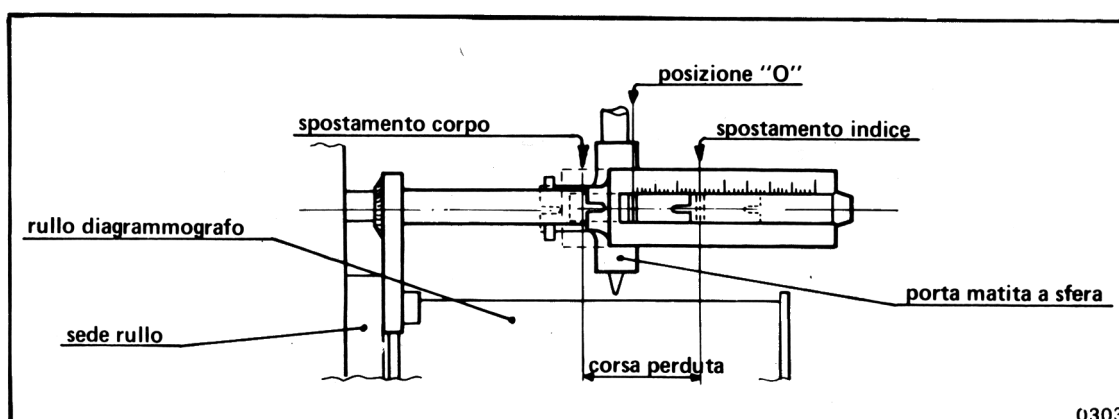

0302

C_r = actual travel of shock absorber

C_s = slide stroke

C_p = length of stroke lost

- If the shock absorber travel is more than 100 mm, say 110 mm, the excess (10 mm) is taken up by reducing the eccentricity of the crankpin by half this amount (5 mm). The check is then repeated and further

adjustments are made, if necessary, to bring the actual travel of the shock absorber to 100 mm.

Next, the shock absorber is tested as follows

- Fit a strip of paper from the reel on the drum. The length of the strip should be slightly more than the circumference of the drum. .

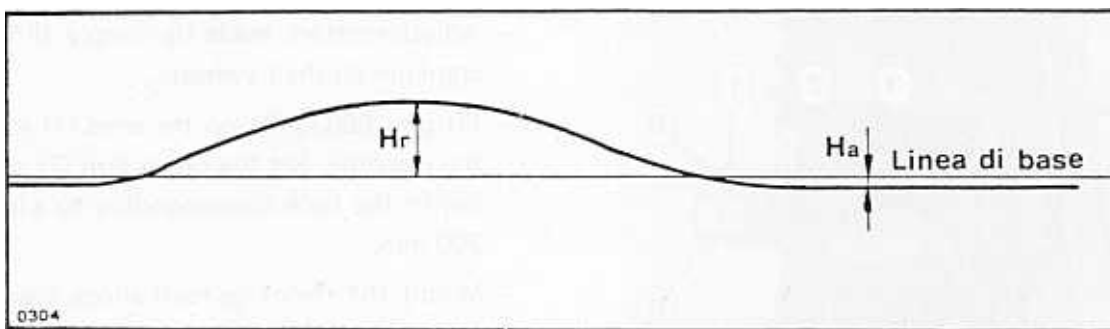

- Dismount the shock absorber and press lightly on the ballpoint pen to mark the base line while turning the machine.
- Remount the shock absorber. Start the machine again and press the pen while the drum makes one complete revolution.

The paper will now have a curved line similar to that shown in fig.

The distances H_a and H_r correspond to the maximum compression and expansion loads during the bump and rebound strokes respectively.

The numbers of cycles per minute carried out by the machine should be checked once the diagram has been traced by applying a rev counter on the drum spindle (drum cycles/m = cycles/min).

H_a and H_r are measured in millimetres to within ± 0.1 .

Load values Q_a and Q_r are determined by multiplying H_a and H_r values by 5.89 N (6 Kg) to obtain results in kilograms. E.g. if H_r is 8 mm, $Q_r = 8 \times 5.89 = 47.04 \text{ N} = 48 \text{ Kg}$.

Tests must be carried out at 120 cycles/min

only.

- The Q values observed must be compared with the loads laid down for the shock absorber concerned.
- A shock absorber must be changed when its load value is less than that prescribed.

N.B. – This test is influenced by shock absorber temperature and the speed of the machine. If the shock absorber is unusually cold, for example, the load will be greater. Alternatively, the load will be smaller if the machine revs fall and the temperature is constant. Before testing, therefore, check that the shock absorber is at a normal temperature and that the electricity supply working the motor is not subject to frequency variations (check the revs, as specified above).

TOOLS REQUIRED

- 88036401 - Telescopic strut testing machine
- 88096421 - Mounting pins

BRAKES

§ 16 4 5500

BENCH TESTING THE HYDRAULIC BRAKES MASTER CYLINDER

Proceed as follows:

Install support 88053069 on test bench 88055657 and secure the master cylinder (1) to the support; then apply a brake fluid reservoir and connect it with the cylinder feed tubes as shown in the figure below.

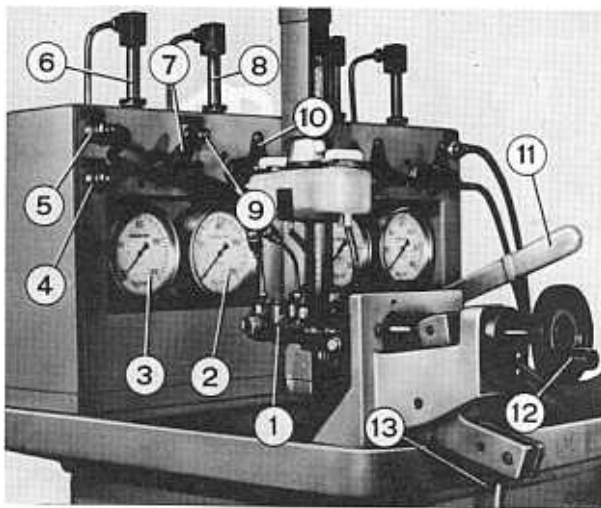

Fig. 16 4/ - Master cylinder on test bench

- By means of the hoses provided, connect the front section of the master to cylinder fitting (4) and the rear section to fitting (5).
- Plug the fittings (9).
- Use pump (11) to fill the reservoir and check that the gauge light goes out when the level exceeds the minimum mark; top up to maximum.
- Move lever (13) to the end of its stroke and open and close immediately cocks (7-10) before releasing the lever. Through the checking windows (6 and 8) brake fluid mixed with air bubbles will be seen flowing by.

Note – During venting operations, check that the level in the pump reservoir never falls below minimum; where necessary, use pump

(11) to top up the level.

- Also make sure that no fluid leaks from the hose connectors or plugs (9).

a) Sealing test.

- Use handwheel (12) to work the master cylinder until gauges (2 and 3) show a pressure of 50.63 bar (50 Kg/cm²) and check that this pressure remains constant for about 10 seconds.
- Reset the pressure gauges to zero by reversing the handwheel (12) manoeuvre.

b) Testing rapid pressure increase.

- Work the rapid braking lever (13) a few times, making sure that the pressures shown on the two gauges (2-3) rise rapidly and reach the same value; when the lever is released, pressures should return just as quickly to zero.

c) Testing the front section by cutting off the circuit connected to the rear section.

- Open cock (10) to simulate a fault in the circuit connected to the rear section of the cylinder.
- Use handwheel (12) to work the master cylinder until the pressure gauge shows a reading of 50.63 bar (50 Kg/cm²); check that this remains constant for at least 10 seconds.

d) Testing the rear section by cutting off the circuit connected with the front section.

- Vent the circuit connected to the rear section of the master cylinder as described above.
- Open cock (7) to simulate a fault in the circuit connected with the front section.
- Use handwheel (12) to work the master cylinder until the pressure gauge (2) shows a reading of 50.65 bar (50 kg/cm²); check that this remains constant for at least 10 seconds.
- When the test is completed, remove the master cylinder from the bench.

TOOLS REQUIRED

- 88053068 - Master cylinder securing adapter
- 88055657 - Brake master cylinder test bench

ELECTRIC SYSTEM

§ 16 4 6400

TESTING THE STARTER MOTOR ON THE TEST BENCH

Proceed as follows:

- Clean the motor with a cloth.
- Fit a crown wheel to the test bench dynamometer; teeth of the crown wheel should have a module equal to that of the starter motor pinion.



Fig. 16 4/26 - Starter motor on the test bench.

- Install the motor (5) on the bench and secure it to the clamping flange.
- Set the motor so that pinion teeth engage correctly with the crown wheel; the distance between the outer face of the pinion at rest and the crown wheel should permit proper meshing of the pinion with the crown wheel.
- Connect the starter motor to the test bench as shown in fig. 16 4/26.

No-load test

- This test shows whether the pinion is meshing correctly with the crown wheel.
- Failure to do so is due to a faulty solenoid switch. It also shows whether motor revs

conform to rated revs shown in the specifications.

- Turn on the motor with switch (6). Read revs on the counter (4) and current input on the ammeter (2).
- Values should correspond to those in the specifications.
- The rev reading refers to the crown wheel; to obtain starter motor revs, multiply the rev counter reading by the ratio between the number of crown wheel and pinion teeth.

Example:

Z_2 = number of crown wheel teeth = 124; Z_1 = number of pinion teeth = 9; n_1 = reading taken on rev counter = 360 rpm; n_2 = starter motor rpm; giving

$$n_2 = n_1 \frac{Z_1}{Z_2} = 360 \cdot \frac{124}{9} = 4960 \text{ rpm}$$

Test under load:

- With the starter motor still connected as shown in fig. 16 4/31, turn on the motor with switch (6); depress the dynamometer control pedal (7) until specified revs are reached.
- Read voltage on the voltmeter (1), current input on the ammeter (2) and pressure on the gauge (3).
- Torque in kg.m is given by the following formula:

$$C = K \frac{p \cdot z}{Z} \quad \text{where}$$

K = dynamometer constant (*)

p = pressure in kg/sq.cm. read on the gauge;

z = number of starter motor pinion teeth;

Z = number of dynamometer crown wheel teeth.

Example:

Let us suppose that the test bench used has a constant $K = 2.07$ and that the crown wheel teeth are $Z = 124$, the pressure reading is $p = 13.2 \text{ kg/cm}^2$. Since the number of pinion

(*) Constant K varies with the type of test bench used. See specifications.

teeth is $z = 9$, we have

$$C = K \cdot p \cdot z : Z = 2,07 \cdot 13 \cdot 9 : 124 = 1.1 \text{ mkg.}$$

The torque value found must conform to specifications.

Short circuit test

- With the starter motor (5) connected as shown in fig. 16 4/31, turn on switch (6) and depress the dynamometer control pedal (7) to stop the motor for an instant (5 sec max).
- Take the reading on the pressure gauge (3) while the motor is stalled.

Static torque is calculated as in the previous test and should agree with the value given in the specifications.

The current and voltage readings may differ from the rated values given in the specifications depending on the charge state of the test bench battery.

The current value to be compared with rated current shown in the specifications is thus given by the following formula:

$$= I \cdot \frac{V_n}{V_L} \text{ where}$$

I = Ammeter reading

V_n = Rated voltage

V_L = Voltmeter reading

Example:

Let us suppose the ammeter reading to be $I = 310$ A and the voltmeter reading to be $V_L = 8$ V; since rated voltage is $V_n = 9$ V and rated current $I_n = 335 - 360$ A, we have:

$$= I \times V_n : V_L = 310 \times 9 : 8 = 349 \text{ A}$$

TOOLS REQUIRED

- 88075016 - Electric units test bench

FILL-UPS

PART	Quantity	
	litres	Kg
Fuel tank (incl. about 8 litres reserve)	59	
Radiator and engine (incl. vehicle heating unit)	14	
Engine oil: sump, filter and pipes	5	4.4
Gearbox and differential oil	1.67	1.51
Steering rack housing	0.14	0.13
Brake fluid reservoir	0.56	0.50
Clutch control liquid reservoir		
Washer reservoir	2	

LUBRICANTS

N.B. - Only the lubricants specified in the Data Sheets should be used.

§ 17 2 0010

**PRE-DELIVERY MAKEREADY OPERATIONS
ON NEW VEHICLES**

The *following operations* must be performed

Checking of levels

- Check and top up, if necessary; engine oil, gearbox oil; brake master cylinder fluid reservoir; cooling system overflow tank; windscreen washer reservoir; battery electrolyte (use distilled water).
- Check tyre pressures, including that of the spare wheel.

Operational checks

- Check the operation of the windscreen wipers and washers. See that the washer jets are properly aimed.
- Check that the turn indicator lights, side lights, headlights, stop and backing lights work properly.

Washing

- Wash the outside of the vehicle using any commercially available neutral soap. Rinse thoroughly.

Cleaning the outside and inside of the vehicle

- Blow out the boot with compressed air. Clean the linings with a cloth soaked in petrol.
- Blow out the interior with compressed air. Clean the inside fittings, including the carpets, with a cloth soaked in rectified petrol.
- Clean the inside of the bonnet. Use a cloth soaked in petrol to clean the ribs and channels.
- Use a cloth soaked in alcohol to clean the inside and outside of the windows and windscreen.
- Clean the outside of the vehicle thoroughly. Pay particular attention to the radiator grille, front and rear lights, bumpers, mouldings and handles.
- Fit the jack, spare wheel cover and tool kit in

their proper places.

- Unpack and mount the hub caps. Mount the front and rear number plate holders and registration plates.
- Place the Owner's Handbook and the Lancia Service Organisation Book in the glove locker.

§ 17 2 0050

**SERVICING COUPON (Jobs to be performed
after 2000-3000 Km)**

The *following operations* must be performed:

- Road test (on reception). This includes the following checks when on the move: operation of dashboard telltales and controls; free travel of brake and clutch pedals; efficiency of the hand brake on a steep slope, or on attempting to break away from a standstill; automatic cut-in of electric fan.
- Check for leaks from brake and clutch control pipes (pedals inside the vehicle), windscreen washer (front compartment), and cooling and fuel circuits.

Rear end of vehicle

- Remove the spare wheel. Take off the air cleaner cover, clean the filter and replace the cover.
- Take off the distributor cap, clean the points and set the opening of the contact breaker points. Remove the plugs, clean them and check the spark gap. Check the ignition stroke and adjust as required.
- Check and, if necessary, adjust the alternator drive belt tension.
- Check that the cylinder head mounting bolts are at the correct torque loading. The engine must be cold when this operation is carried out.
- Next, check that the clearance of the inlet and exhaust valves is correct. Once again, the engine must be cold. Note: adjustment of these clearances is not provided for in the servicing coupon.

Refit the distributor cap and plugs.

Under the vehicle

- Check for leaks from the engine, gearbox and differential unit, suspension struts, and brake pipes. Make sure that the constant velocity joint guards, the suspension ball joints, the control linkage joints, and the steering housing guards are not damaged.
- Check that the exhaust pipes and manifold are firmly fastened.
- Check that the bolts holding the front bar silent blocks are tightened to the correct torque loading.
- Check that the bolts holding the rear bar silent blocks are tightened to the correct torque loading.

Top and bottom of the vehicle

- Check the hand brake travel. Adjust if more than 3-4 clicks are heard before the brake operates.

- Start the engine and leave it running until the temperature required for setting the slow-running mechanism is reached.
- Lubricate the front and rear bonnet release controls, the seat sliders and the door locks and hinges.
- Check that the bolts holding the door lock blocks are tight.
- Set the slow-running mechanism
- Change the engine and differential oil.
- Check and, if necessary, top up: battery electrolyte; washer fluid; coolant overflow tank; brake master cylinder and clutch servo control reservoirs.
- Check tyre pressure, including that of the spare wheel. The tyres must be cold.
- Top up the differential.
- Top up the engine oil. Run the engine for a short period and recheck the level 2-3 minutes after turning off the engine.
- Replace the spare wheel.
- Road test (for approval).

Note:

The chart lists the periodic maintenance operations carried out after various numbers of kilometres at Service Stations or Workshops.

The time required for these operations (marked by an X) is given in the schedule of times in accordance with the paragraph numbers shown at the head of each column.

It will be obvious that the overall time needed to perform the tasks at any given mileage will be the sum of the times shown.

Example:**At 5000 Km**

Service Station

Operations required: Para. 17 2 0100 Nos. 1-5.

Time 20.0 minutes

Workshop

Operations required: Para. 17 2 0200 Nos. 12-12-14-18. Time 80.0 minutes.

Total time for 5000 km maintenance: 20 + 80 = 100.0 minutes.

At 30,000 Km

Service Station

Operations required: Para. 17 2 1100 Nos. 1 to 5. Time 50.0 minutes.

Workshop

Operations required: Para. 17 2 1200 Nos. 6-8-10-11-12-13-14-18. Time 260.0 minutes.

Total time for 30,000 Km maintenance: 50 + 260 = 310 minutes.

